

**WIRE COLOR SCHEME**  
 BLACK - LINE VOLTAGE  
 RED - AC CONTROL  
 WHITE - AC GROUNDED  
 BLUE - DC CONTROL  
 GREEN - CHASSIS GROUND

- NOTES:**
- \* INDICATES COMPONENTS NOT SUPPLIED BY MANUFACTURER.
  - REFER TO THE INSTALLATION AND OPERATION MANUAL FOR DRIVE FUNCTIONS AND PARAMETER SETTINGS.
  - FEEDER CIRCUIT PROTECTION, INPUT POWER AND MOTOR WIRING MUST BE SELECTED IN ACCORDANCE WITH THE N.E.C., ANY APPLICATION LOCAL CODES AND THE LOAD CURRENT RATING.
  - REPLACE JUMPER 'J1' WITH NORMALLY CLOSED SAFETY INTERLOCK CONTACT AS NECESSARY. CONTACT MUST BE RATED 1/4 HP @ 120VAC MINIMUM.
  - PANEL MAY REQUIRE DERATING, CONSULT DRIVE MANUAL OR FACTORY FOR FOLLOWING CONDITIONS:
    - HIGHER SWITCHING FREQUENCY THEN DRIVE DEFAULT
    - HIGHER THEN PANEL LISTED AMBIENT TEMPERATURES
    - ELEVATION ABOVE 3300 FEET (1000 METERS)
    - LONG MOTOR LEAD LENGTHS

**WARNING!**  
 THE FOLLOWING TABLE LIST THE PARAMETERS THAT ARE SET DIFFERENT FROM THE DRIVE DEFAULT SETTINGS. ADDITIONAL PARAMETER SETTINGS MAY BE REQUIRED FOR YOUR APPLICATION.

**DRIVE PARAMETER SETTINGS**

| PARAMETER # | NAME              | SETTING | VALUE                |
|-------------|-------------------|---------|----------------------|
| 0-02        | MOTOR SPEED UNIT  | 1       | HZ                   |
| 0-03        | REGIONAL SETTINGS | 1       | NORTH AMERICA        |
| 1-03        | TORQUE CHAR.      | 3       | AUTO ENERGY OPTIM VT |
| 5-02        | TERMINAL 29 TYPE  | 1       | OUTPUT               |
| 5-31        | TERMINAL 29       | 5       | RUNNING              |
| 14-20       | RESET MODE        | 13      | INFINITE AUTO REST   |

|     |            |      |   |     |     |   |     |             |  |   |
|-----|------------|------|---|-----|-----|---|-----|-------------|--|---|
| B   |            |      | -NOTICE-<br>THIS DRAWING IS PROPRIETARY AND SHALL NOT BE COPIED OR ITS CONTENTS DISCLOSED TO OUTSIDE PARTIES WITHOUT THE WRITTEN CONSENT OF THE TRANE COMPANY | DRN | DTM | NAME<br>NEMA 3R,480V,2C<br>,MAIN DISC,MAIN & DRIVE FUSE<br>,3MB2,CONTACT MOTOR SELECT,1 FAN |     |             | THE TRANE COMPANY<br>A DIVISION OF<br>AMERICAN STANDARD INC. |   |
| A   |            |      |   | APR | DTM | MODEL   | VLT | PAGE 1 OF 2 | SIZE   | A |
| DR  | ECNSP09001 | 1/09 |   |     |     |   |     |             |  |   |
| REV | ECN        | DATE |   |     |     |   |     |             |  |   |

**WIRE COLOR SCHEME**  
 BLACK - LINE VOLTAGE  
 RED - AC CONTROL  
 WHITE - AC GROUNDED  
 CIRCUIT CONDUCTOR  
 BLUE - DC CONTROL  
 GREEN - CHASSIS GROUND

**TERMINAL IDENTIFICATION**  
 [X] - DRIVE TERMINAL  
 (X) - CUSTOMER TERMINAL

**CUSTOMER DRY CONTACT RATINGS**

| RELAY             | CONTACT RATING                  |
|-------------------|---------------------------------|
| CR6               | 5A @ 120VAC<br>1/10 HP @ 120VAC |
| M2, M3,<br>M4, M5 | 10A @ 120/240VAC                |

**CONTACT SEQUENCE CHART FOR S1**  
X INDICATES CONTACT CLOSED

| POSITION | DRIVE | OFF | BYPASS |
|----------|-------|-----|--------|
| 13-14    |       |     | X      |
| 23-24    | X     |     |        |

**CONTACT SEQUENCE CHART FOR S2**  
X INDICATES CONTACT CLOSED

| POSITION | MOTOR 1 | AUTO | MOTOR 2 |
|----------|---------|------|---------|
| 11-12    | X       | X    |         |
| 13-14    |         |      | X       |
| 21-22    |         | X    | X       |
| 23-24    | X       |      |         |

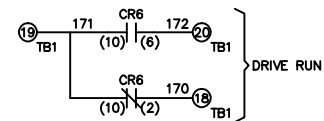
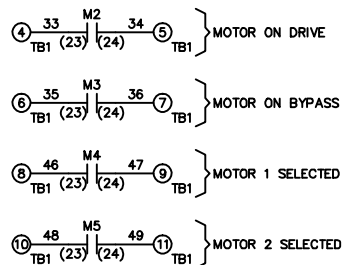
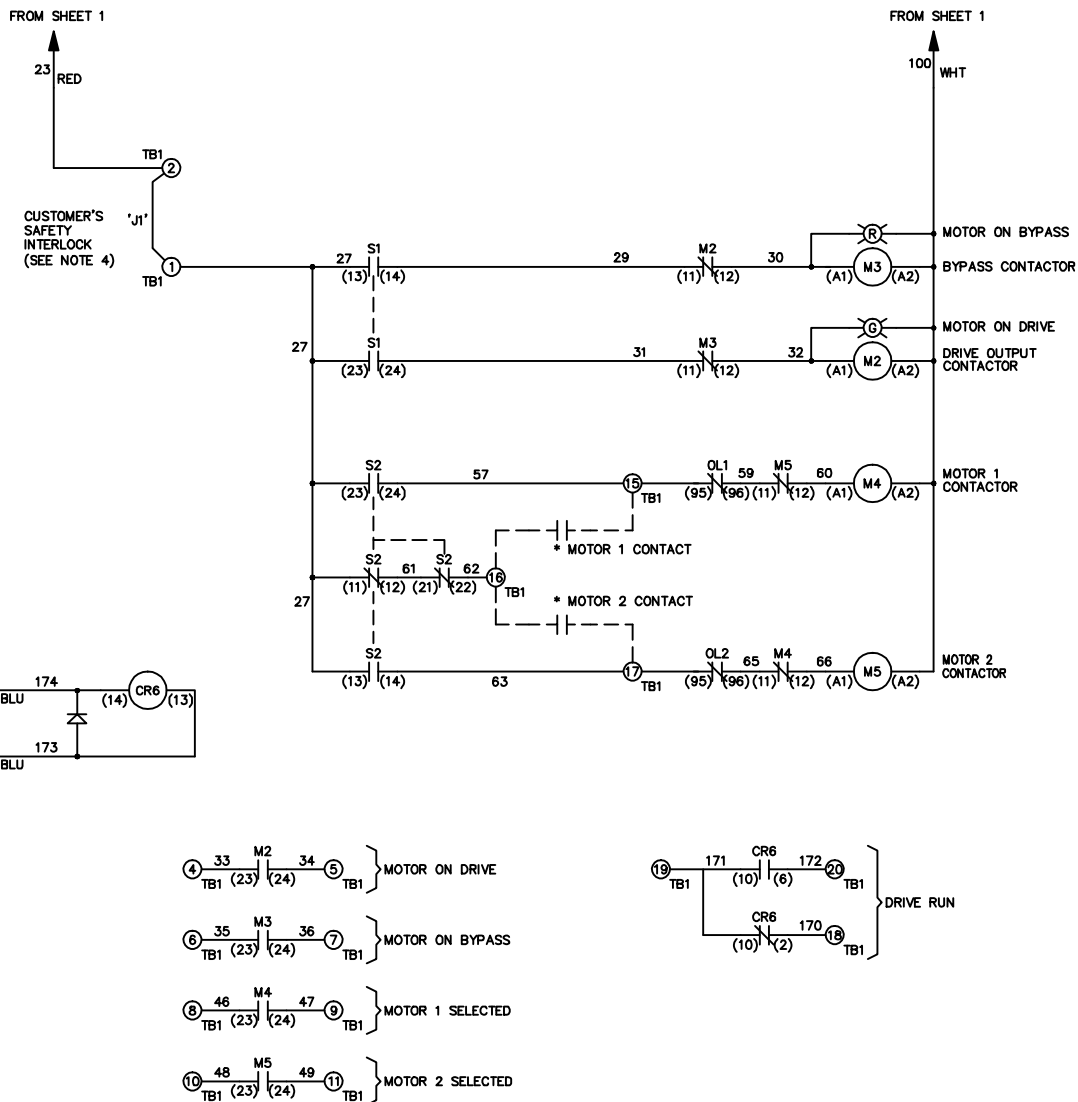
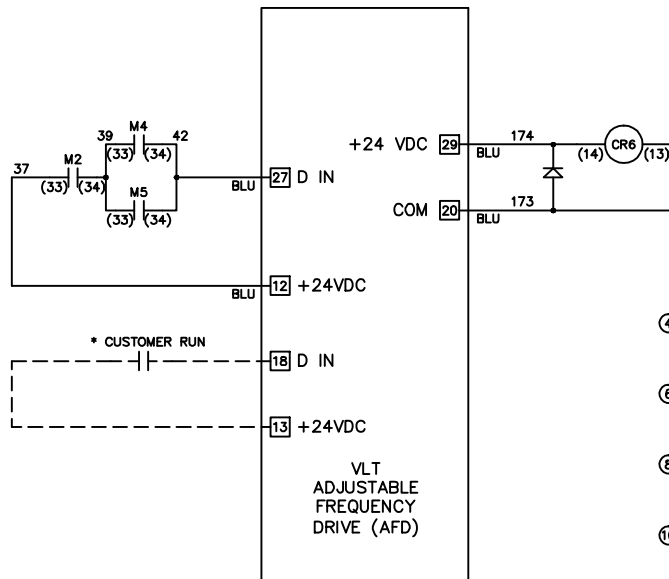

|     |            |      |
|-----|------------|------|
| B   |            |      |
| A   |            |      |
| DR  | ECNSP09001 | 1/09 |
| REV | ECN        | DATE |

-NOTICE-  
 THIS DRAWING IS PROPRIETARY AND SHALL NOT  
 BE COPIED OR ITS CONTENTS DISCLOSED TO  
 OUTSIDE PARTIES WITHOUT THE WRITTEN  
 CONSENT OF THE TRANE COMPANY

DRN DTM  
 APR DTM

NAME NEMA 3R,480V,2C  
 ,MAIN DISC,MAIN & DRIVE FUSE  
 ,3MB2,CONTACT MOTOR SELECT,1 FAN  
 MODEL VLT PAGE 2 OF 2 SIZE A DWG NO. 174N4074

**THE TRANE COMPANY**  
 A DIVISION OF  
 AMERICAN STANDARD INC.