

WIRE COLOR SCHEME	
BLACK	- LINE VOLTAGE
RED	- AC CONTROL
WHITE	- AC GROUNDED
	CIRCUIT CONDUCTOR
BLUE	- DC CONTROL
GREEN	- CHASSIS GROUND

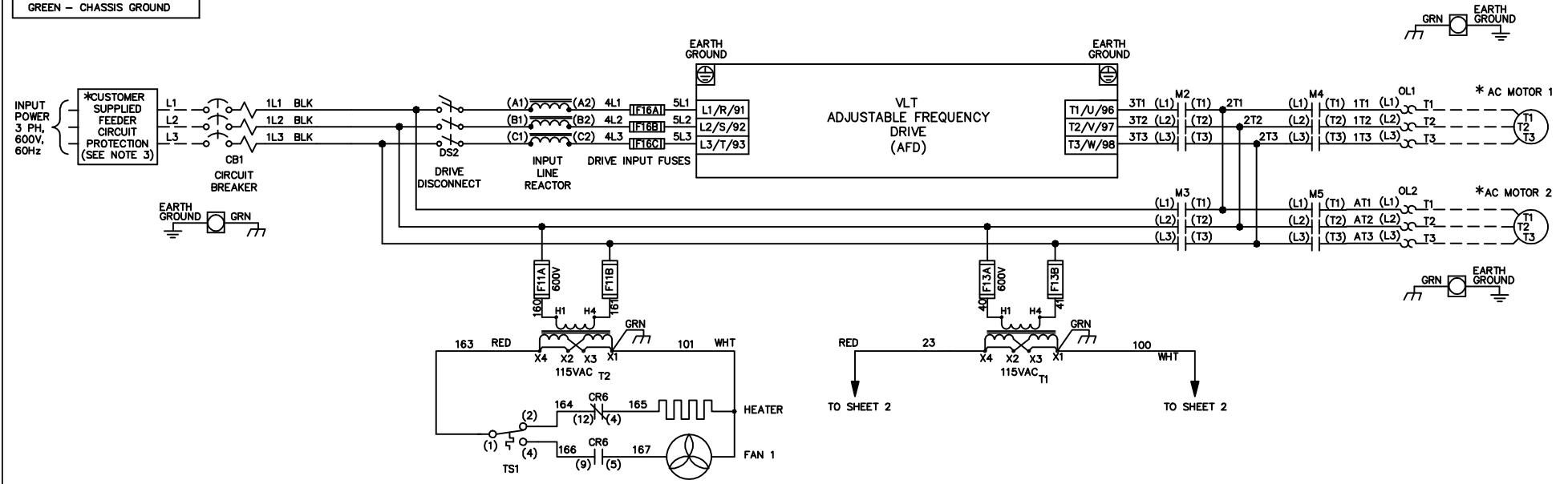

**WARNING!**  
 THE FOLLOWING TABLE LIST THE PARAMETERS THAT ARE SET DIFFERENT FROM THE DRIVE DEFAULT SETTINGS. ADDITIONAL PARAMETER SETTINGS MAY BE REQUIRED FOR YOUR APPLICATION.

DRIVE PARAMETER SETTINGS

PARAMETER #	NAME	SETTING	VALUE
0-02	MOTOR SPEED UNIT	1	HZ
0-03	REGIONAL SETTINGS	1	NORTH AMERICA
1-03	TORQUE CHAR.	3	AUTO ENERGY OPTIM VT
5-02	TERMINAL 29 TYPE	1	OUTPUT
5-31	TERMINAL 29	5	RUNNING
14-20	RESET MODE	13	INFINITE AUTO REST

- NOTES:
- \* INDICATES COMPONENTS NOT SUPPLIED BY MANUFACTURER.
  - REFER TO THE INSTALLATION AND OPERATION MANUAL FOR DRIVE FUNCTIONS AND PARAMETER SETTINGS.
  - FEEDER CIRCUIT PROTECTION, INPUT POWER AND MOTOR WIRING MUST BE SELECTED IN ACCORDANCE WITH THE N.E.C., ANY APPLICATION LOCAL CODES AND THE LOAD CURRENT RATING.
  - REPLACE JUMPER 'J1' WITH NORMALLY CLOSED SAFETY INTERLOCK CONTACT AS NECESSARY. CONTACT MUST BE RATED 1/4 HP @ 120VAC MINIMUM.
  - PANEL MAY REQUIRE DERATING, CONSULT DRIVE MANUAL OR FACTORY FOR FOLLOWING CONDITIONS:
    - HIGHER SWITCHING FREQUENCY THEN DRIVE DEFAULT
    - HIGHER THEN PANEL LISTED AMBIENT TEMPERATURES
    - ELEVATION ABOVE 3300 FEET (1000 METERS)
    - LONG MOTOR LEAD LENGTHS

B			-NOTICE-	DRN	DTM	NAME			THE TRANE COMPANY A DIVISION OF AMERICAN STANDARD INC.	
A				THIS DRAWING IS PROPRIETARY AND SHALL NOT BE COPIED OR ITS CONTENTS DISCLOSED TO OUTSIDE PARTIES WITHOUT THE WRITTEN CONSENT OF THE TRANE COMPANY			NEMA 3R,600V,2C ,MAIN CB & DRIVE DISC,DRIVE FUSE ,3MB2,IR,CONTACT MOTOR SELECT,1 FAN			
DR	ECNSP09001	1/09		APR	DTM	MODEL	VLT	PAGE 1 OF 2	SIZE A	DWG NO. 174N4323
REV	ECN	DATE								

**WIRE COLOR SCHEME**  
 BLACK - LINE VOLTAGE  
 RED - AC CONTROL  
 WHITE - AC GROUNDED  
 CIRCUIT CONDUCTOR  
 BLUE - DC CONTROL  
 GREEN - CHASSIS GROUND

**TERMINAL IDENTIFICATION**  
 [X] - DRIVE TERMINAL  
 (X) - CUSTOMER TERMINAL

**CUSTOMER DRY CONTACT RATINGS**

RELAY	CONTACT RATING
CR6	5A @ 120VAC 1/10 HP @ 120VAC
M2, M3, M4, M5	10A @ 120/240VAC

**CONTACT SEQUENCE CHART FOR S1**  
X INDICATES CONTACT CLOSED

POSITION	DRIVE	OFF	BYPASS
CONTACT 13-14			X
CONTACT 23-24	X		

**CONTACT SEQUENCE CHART FOR S2**  
X INDICATES CONTACT CLOSED

POSITION	MOTOR 1	AUTO	MOTOR 2
CONTACT 11-12	X	X	
CONTACT 13-14			X
CONTACT 21-22		X	X
CONTACT 23-24	X		

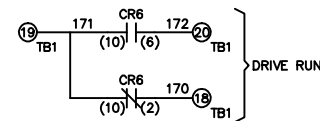
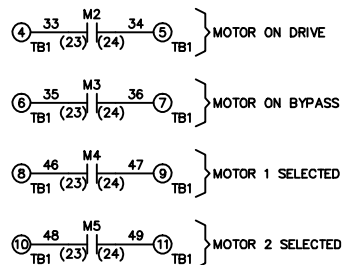
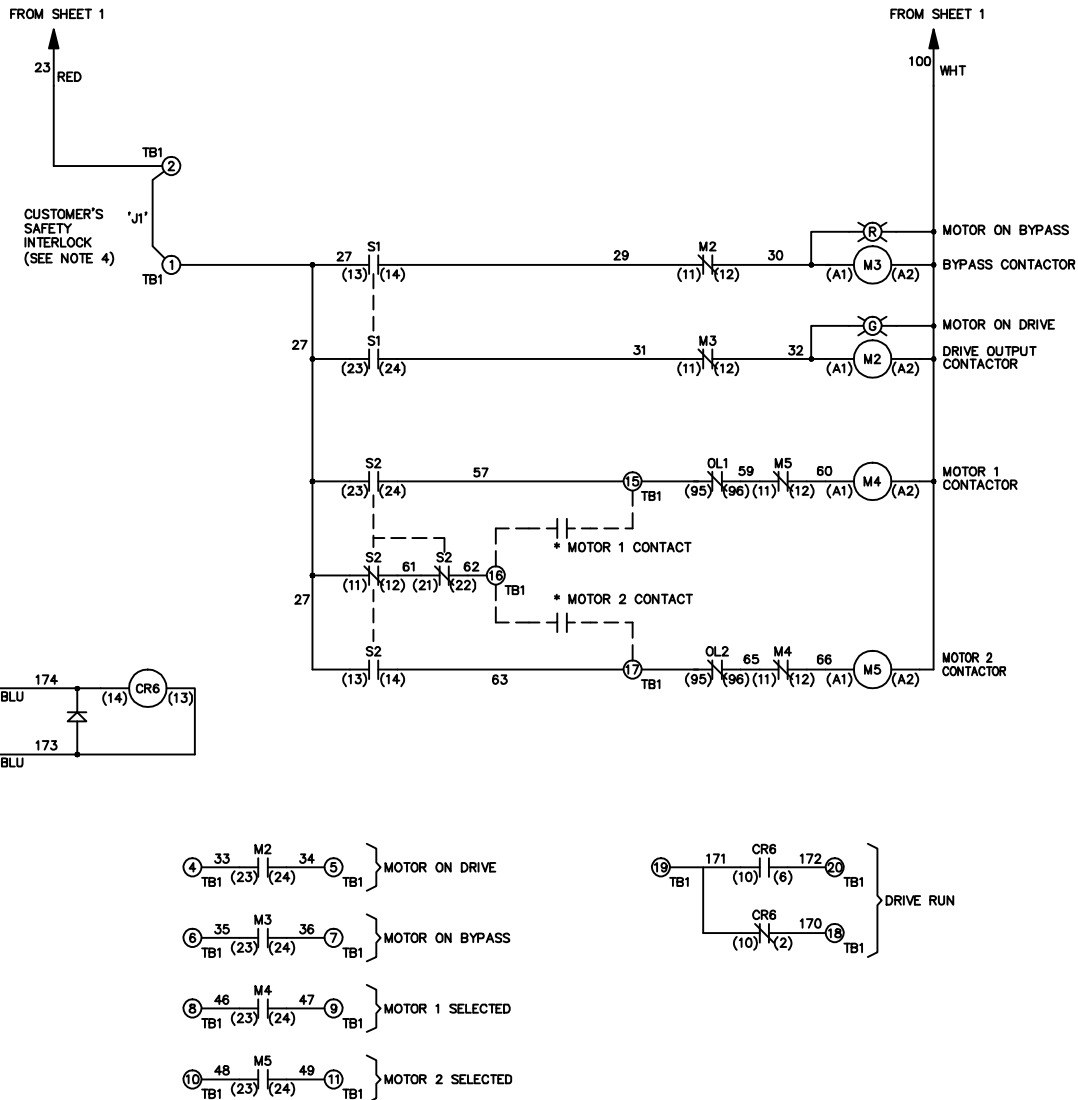
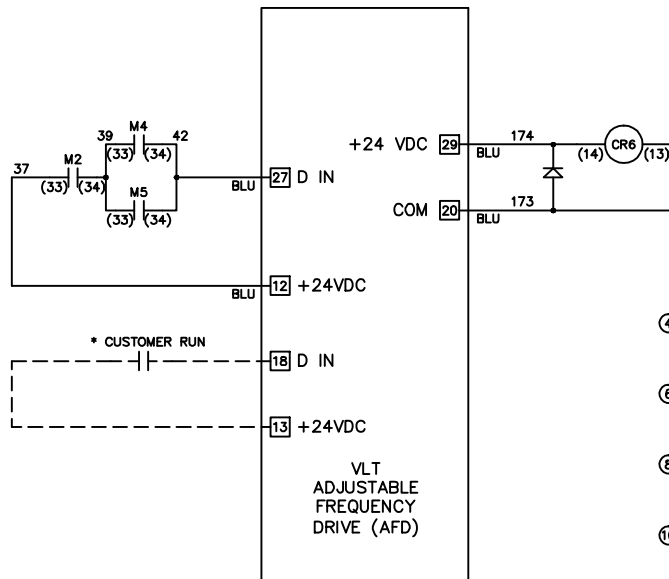

B			<b>-NOTICE-</b> THIS DRAWING IS PROPRIETARY AND SHALL NOT BE COPIED OR ITS CONTENTS DISCLOSED TO OUTSIDE PARTIES WITHOUT THE WRITTEN CONSENT OF THE TRANE COMPANY	DRN	DTM	NAME		NEMA 3R,600V,2C		<b>THE TRANE COMPANY</b> A DIVISION OF AMERICAN STANDARD INC.	
A				APR	DTM	,MAIN CB & DRIVE DISC,DRIVE FUSE		,3MB2,IR,CONTACT MOTOR SELECT,1 FAN			
DR	ECNSP09001	1/09				MODEL	VLT	PAGE	2 OF 2	SIZE	A
REV	ECN	DATE								DWG NO.	174N4323