



Operating Instructions

TR200 Embedded BACnet

SAFETY WARNING

Only qualified personnel should install and service the equipment. The installation, starting up, and servicing of heating, ventilating, and air-conditioning equipment can be hazardous and requires specific knowledge and training. Improperly installed, adjusted or altered equipment by an unqualified person could result in death or serious injury. When working on the equipment, observe all precautions in the literature and on the tags, stickers, and labels that are attached to the equipment.

Table of Contents

Safety.....	2
Copyright, Limitation of Liability and Revision Rights	2
Before Commencing Repair Work.....	4
Special Conditions.....	5
Introduction.....	6
How to Install.....	8
The BACnet Interface.....	8
Switches S201, S202, and S801	10
Bus Cabling.....	12
How to Configure the System.....	13
Configuring BACnet.....	13
Example of a simple setup of BACnet.....	14
How to Control the Frequency Converter.....	15
Network Frequency Converter Control Inputs and -Outputs.....	16
Drive Feedback to Network.....	21
BIBBs.....	21
Parameters.....	23
Parameter Overview.....	23
Parameter Description.....	24
Troubleshooting.....	31
Alarm, Warning and Extended Status Word.....	31
Alarm Words.....	32
Warning Words	33
Index.....	34



Safety

Copyright, Limitation of Liability and Revision Rights

This publication contains information proprietary to Trane. By accepting and using this manual the user agrees that the information contained herein will be used solely for operating equipment from Trane or equipment from other vendors provided that such equipment is intended for communication with Trane equipment over a serial communication link. This publication is protected under the Copyright laws of most countries.

Trane does not warrant that a software program produced according to the guidelines provided in this manual will function properly in every physical, hardware or software environment.

Although Trane has tested and reviewed the documentation within this manual, Trane makes no warranty or representation, neither expressed nor implied, with respect to this documentation, including its quality, performance, or fitness for a particular purpose.

In no event shall Trane be liable for direct, indirect, special, incidental, or consequential damages arising out of the use, or the inability to use information contained in this manual, even if advised of the possibility of such damages. In particular, Trane is not responsible for any costs, including but not limited to those incurred as a result of lost profits or revenue, loss or damage of equipment, loss of computer programs, loss of data, the costs to substitute these, or any claims by third parties.

Trane reserves the right to revise this publication at any time and to make changes to its contents without prior notice or any obligation to notify former or present users of such revisions or changes.

Warnings, Cautions and Notices

Note that warnings, cautions and notices appear at appropriate intervals throughout this manual. Warnings are provide to alert installing contractors to potential hazards that could result in personal injury or death. Cautions are designed to alert personnel to hazardous situations that could result in personal injury, while notices indicate a situation that could result in equipment or property-damage-only accidents.

Your personal safety and the proper operation of this machine depend upon the strict observance of these precautions.

Warnings, Cautions and Notices appear at appropriate sections throughout this literature. Read these carefully.

WARNING

Indicates a potentially hazardous situation which, if not avoided, could result in death or serious injury.

CAUTION

Indicates a potentially hazardous situation which, if not avoided, could result in minor or moderate injury. It could also be used to alert against unsafe practices.

NOTICE

Indicates a situation that could result in equipment or property-damage only accidents.

Note

Indicates something important to be noted by the reader.

 Indicates default setting

Safety Note

WARNING

Failure to follow instructions below could result in death or serious injury.

Safety Regulations

1. The frequency converter must be disconnected from mains if repair work is to be carried out. Check that the mains supply has been disconnected and that the necessary time has passed before removing motor and mains plugs.
2. The [STOP/RESET] key on the keypad of the frequency converter does not disconnect the equipment from mains and is thus not to be used as a safety switch.
3. Correct protective earthing of the equipment must be established, the user must be protected against supply voltage, and the motor must be protected against overload in accordance with applicable national and local regulations.
4. The earth leakage currents are higher than 3.5 mA.
5. Protection against motor overload is set by par. 1-90 [Motor Thermal Protection](#). If this function is desired, set par. 1-90 [Motor Thermal Protection](#) to data value [ETR trip] (default value) or data value [ETR warning]. Note: The function is initialized at 1.16 x rated motor current and rated motor frequency. For the North American market: The ETR functions provide class 20 motor overload protection in accordance with NEC.
6. Do not remove the plugs for the motor and mains supply while the frequency converter is connected to mains. Check that the mains supply has been disconnected and that the necessary time has passed before removing motor and mains plugs.
7. Please note that the frequency converter has more voltage inputs than L1, L2 and L3, when load sharing (linking of DC intermediate circuit) and external 24 Vdc have been installed. Check that all voltage inputs have been disconnected and that the necessary time has passed before commencing repair work.

WARNING

Warning against Unintended Start

1. The motor can be brought to a stop by means of digital commands, bus commands, references or a local stop, while the frequency converter is connected to mains. If personal safety considerations make it necessary to ensure that no unintended start occurs, these stop functions are not sufficient.
2. While parameters are being changed, the motor may start. Consequently, the stop key [STOP/RESET] must always be activated; following which data can be modified.
3. A motor that has been stopped may start if faults occur in the electronics of the frequency converter, or if a temporary overload or a fault in the supply mains or the motor connection ceases.

Consequently, disconnect all electric power, including remote disconnects before servicing. Follow proper lockout/tagout procedures to ensure the power can not be inadvertently energized. Failure to follow recommendations could result in death or serious injury.

Before Commencing Repair Work

WARNING

Hazardous Voltage!

1. Disconnect the frequency converter from mains
2. Disconnect DC bus terminals 88 and 89
3. Wait at least the time mentioned in section General Warning above
4. Remove motor cable

Failure to follow recommendations could result in death or serious injury.

Special Conditions

Electrical ratings:

The rating indicated on the nameplate of the frequency converter is based on a typical 3-phase mains power supply, within the specified voltage, current and temperature range, which is expected to be used in most applications.

The frequency converters also support other special applications, which affect the electrical ratings of the frequency converter.

Special conditions which affect the electrical ratings might be:

- Single phase applications
- High temperature applications which require de-rating of the electrical ratings
- Marine applications with more severe environmental conditions.

Other applications might also affect the electrical ratings.

Consult the relevant sections in this manual and in the TR200 Design Guide for information about the electrical ratings.

Installation requirements:

The overall electrical safety of the frequency converter requires special installation considerations regarding:

- Fuses and circuit breakers for over-current and short-circuit protection
- Selection of power cables (mains, motor, brake, loadsharing and relay)
- Grid configuration (grounded delta transformer leg, IT, TN, etc.)
- Safety of low-voltage ports (PELV conditions).

Consult the relevant clauses in these instructions and in the TR200 Design Guide for information about the installation requirements.

Introduction

About this Manual

First time users can obtain the most essential information for quick installation and set-up in these chapters:

- Introduction
- How to Install
- How to Configure the System

For more detailed information including the full range of set-up options and diagnosis tools please refer to the chapters:

- How to Control the Frequency Converter
- Parameters
- Troubleshooting

Technical Overview

BACnet (Building Automation and Control Network) is an open data communications protocol, American National Standard (ANSI/ASHRAE 135-2004). BACnet provides a means by which computer-based control equipment from different manufacturers can work together. BACnet is designed to handle many types of building controls, including HVAC, lighting, security, fire, access control, maintenance and waste management. BACnet permits flexibility for expansion and different equipment combinations.

Background information	
Protocol name:	BACnet
Technology developer:	ASHRAE
Year introduced:	1995
Governing standards:	ANSI/ASHRAE Standard 135-2004 version 4, ISO 16484-5
Openness:	Open specification
Physical characteristics	
Network topology:	Bus
Physical media:	Shielded twisted pair
Max. Distance at low speed:	1200 meters (4000 feet)
Transport mechanism	
Communication methods:	Requestor/non-requestor
Baud Rates Supported:	9600, 19200, 38400, 76800
Termination:	120 ohm

Assumptions

This manual assumes you are using the BACnet Protocol with a TR200 series frequency converter. It is also assumed that your system is equipped with a firmware supporting the BACnet communication services required by your application and that all requirements stipulated in the BACnet standard, as well as those pertaining to the Variable Frequency Drive are strictly observed as well as all limitations therein fully respected.

Background Knowledge

The Trane implementation of the BACnet Protocol is designed to communicate with any system complying with the BACnet TP standard. Familiarity with the PC, BMS or PLC used as a requestor in the system is assumed. Issues regarding hardware or software produced by other manufacturers are beyond the scope of this manual and are not the responsibility of Trane.

If you have questions regarding set-up of requestor-to-requestor communication or communication to a non-Trane non-requestor, please consult the appropriate manuals.

Available Literature for TR200

- Operating Instructions BAS-SVX19 provide the necessary information for getting the drive up and running.
- Operating Instructions TR200 High Power BAS-SVX21
- Design Guide BAS-SVX23 entails all technical information about the drive and customer design and applications.
- Programming Guide BAS-SVP04 provides information on how to programme and includes complete parameter descriptions.

x = Revision number

yy = Language code

Trane technical literature is available in print from your local Trane Sales Office or online at:

www.trane.com/vfd

Abbreviations

ACI	Acyclical Control Interval
AOC	Application Orientated Controller
AV	Analog Variable
BMS	Building Management System
BV	Binary Variable
CAN	Controller Area Network
CTW	Control Word
EEPROM	Electrical Erasable Programmable Read Only Memory
EIA	Electronic Industries Association: Specifies of the EIA Standard RS 485-A
EMC	Electromagnetic Compatibility
IND	Sub index
I/O	Input/Output
ISO	International Standards Organization
LCD	Liquid Crystal Display
LCP	Local Control Panel
LED	Light Emitting Diode
MAV	Main Actual Value
MRV	Main Reference Value
PC	Personal Computer
PCD	Process Data
PDU	Protocol Data Unit
PELV	Protected Extra Low Voltage
PLC	Programmable Logic Control
PNU	Parameter Number
PVA	Parameter Value
RC	Request/Response Characteristics
STW	Status Word

How to Install

The BACnet Interface

Cabling

Cable lengths and number of nodes

The maximum cable length allowable in one segment is dependent on the transmission speed. The total cable length includes drop cables if any. A drop cable is the connection from the main bus cable to each node.

Drop cable connection (i.e. T-connection) is not recommended, due to the increased risk of reflection occurring. Instead, Trane recommends direct connection of the frequency converter.

Note that a repeater is a node in both of the two segments it connects. The number of frequency converters is based on a single requestor system. If there are two or more devices (e.g. PC tools, Routers), the number of frequency converters must be reduced correspondingly.

- Maximum length of an TP segment: 1200 meters (4000 feet)
- Impedance: 100 to 130 Ohm
- Resistance: <110 Ohm/km
- Capacitance: <100 pF/m
Distributed capacitance between conductors and shield shall be less than 200 pF per meter
- Cross section: 0.82 mm² conductor area, corresponding to AWG 18
- Cable type: twisted in pairs, 1 x 2, or 2 x 2 wires
- Screening: Copper-braided screen or braided screen and foil screen

Use of the same cable type throughout the entire segment is recommended to avoid impedance mismatch.

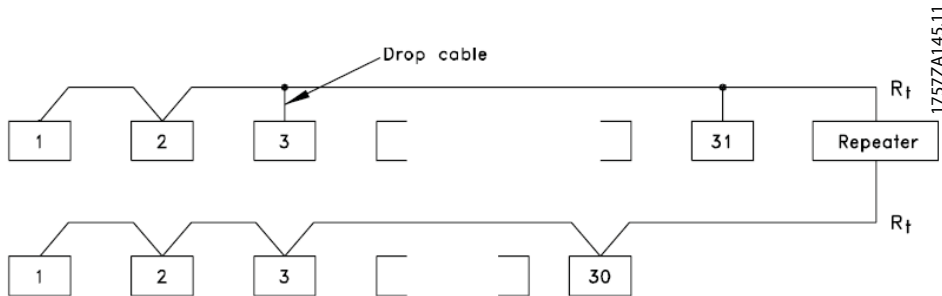

Network Connection

Connect the frequency converter to the RS-485 network as follows (see also diagram):

1. Connect signal wires to terminal 68 (P+) and terminal 69 (N-) on the main control board of the frequency converter.
2. Connect the cable screen as described under chapter *Bus Cabling*.

Note

Screened, twisted-pair cables are recommended in order to reduce noise between conductors.

Network Termination

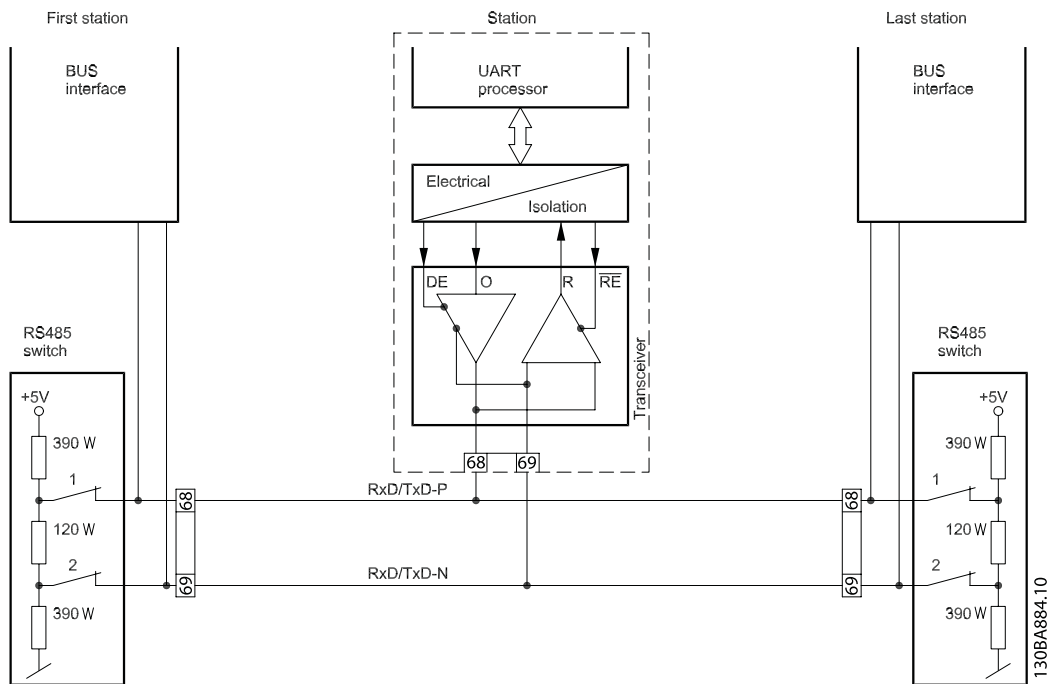

Maximum Cable Lengths

Maximum total bus cable length: 4000Feet ~ 1200Meter

Switches S201, S202, and S801

Switches S201 (A53) and S202 (A54) are used to select a current (0-20 mA) or a voltage (-10 to 10 V) configuration of the analog input terminals 53 and 54 respectively.

Switch S801 (BUS TER.) can be used to enable termination on the RS-485 port (terminals 68 and 69).

See drawing *Diagram showing all electrical terminals* in section *Electrical Installation*.

Default setting:

S201 (A53) = OFF (voltage input)

S202 (A54) = OFF (voltage input)

S801 (Bus termination) = OFF

Note

When changing the function of S201, S202 or S801 be careful not to use force for the switch over. It is recommended to remove the keypad fixture (cradle) when operating the switches. The switches must not be operated with power on the frequency converter.

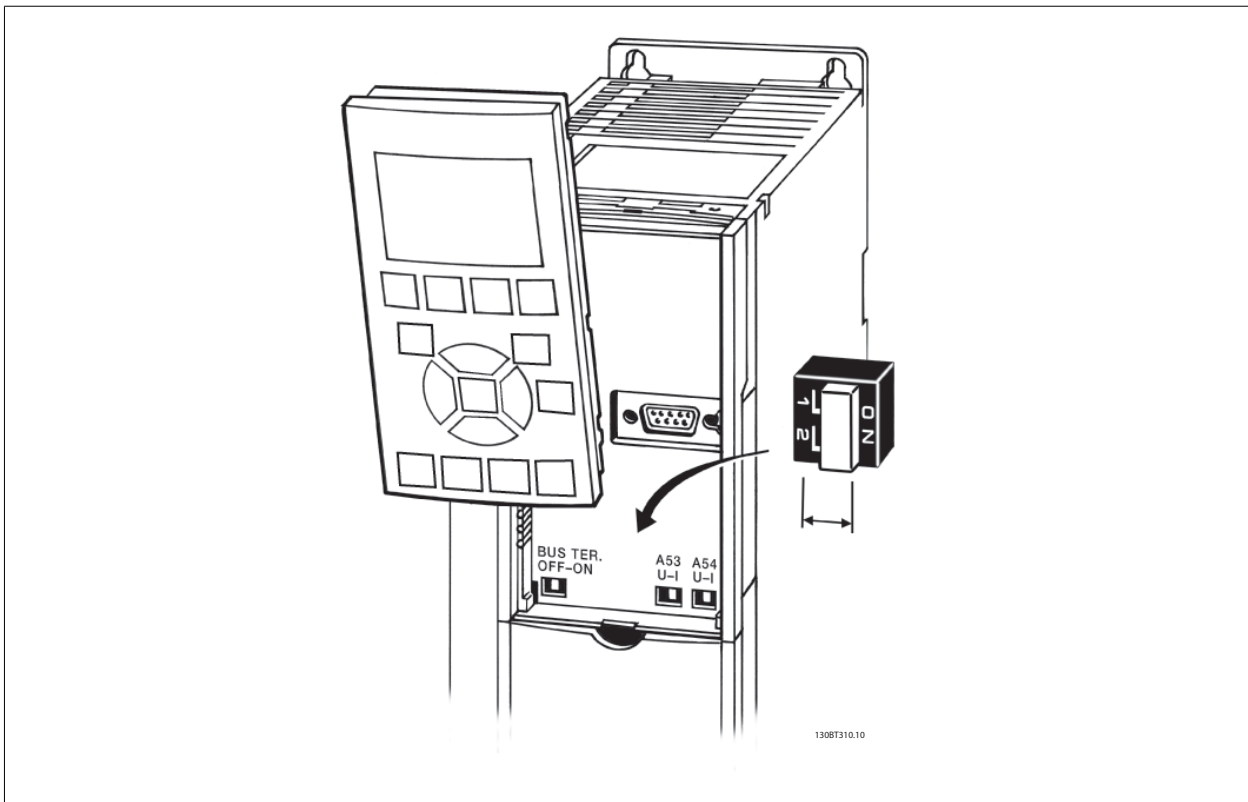

Cable Routing

The BACnet communication cable must be kept away from motor and brake resistor cables to avoid coupling of high frequency noise from one cable to the other. Normally a distance of 200 mm (7.9 in.) is sufficient, but maintaining the greatest possible distance between cables is generally recommended, especially where cables run in parallel over long distances.

When crossing is unavoidable, the BACnet cable must cross motor and brake resistor cables at an angle of 90 degrees.

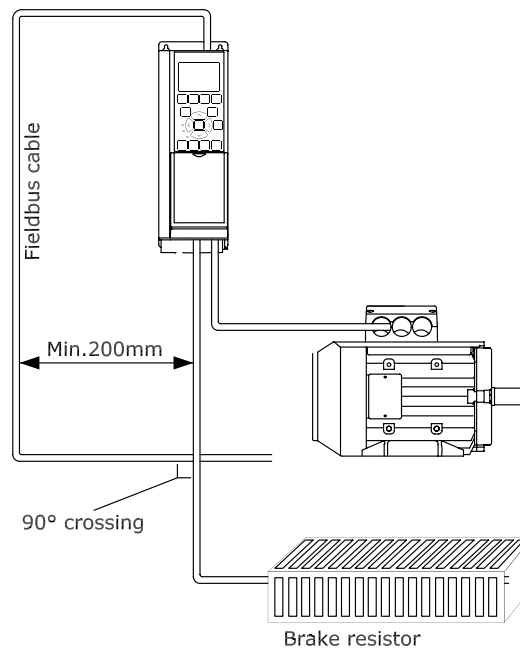

Bus Cabling

EMC Precautions

The following EMC precautions are recommended to achieve interference-free operation of the BACnet network. Additional EMC information is available in the *TR200 Design Guide, MG. 12.IX.YY*. Please also consult the BACnet requestor manual for further installation guidelines.

Note

Ensure compliance with relevant national and local regulations, for example in protective earth connection.

Single Ground Shielding

For installing the bus cable on TP, two different strategies can be followed, Single ground of shield and multiple ground of shield. Each strategy has both advantages and disadvantages. The following chapter explains the different between the two strategies. The single ground shield is specified in the ANSI/ASRAHE 135-2004 standard. The solution benefits by having only one ground connection of the shield, by doing so the possibility for ground loop of equalizing current is heavily reduced. In these systems the shield of the TP cables has to be isolated from ground at all stations, except one. At each station the shield from the two cables has to be connected with each other, and isolated from ground. The best solution for this has been proven to be the use of shrink tubes. The single ground shielding is a good approach where the system uses long bus cables. If two buildings have to be connected over the same P bus cable, the use of fiber optic has to be considered. This will prevent that a lightning stroke will be carried from one building to another, and problem with difference in earth potential can be neglected.

Multiple Ground Shielding

If the distance between the individual drives is limited (e.g. inside a cabinet or in one control room) Trane recommends connecting the screen to ground at both ends of the bus cable. This ensures the maximum protection from EMC noise. Connecting the screen at each end will require that each BACnet device has the same earth potential or an equalizing current will flow in the screen of the cable and cause disturbance and poor performance of the system. Low impedance to ground connection of the screen can be achieved by connecting the surface of the screen to ground, by means of a cable clamp or a conductive cable gland. The TR200 Series supplies various clamps and brackets to enable a proper ground connection of the BACnet cable screen.

Trane recommends to connect the screen to ground at both ends of the bus cable. This ensures the maximum protection from EMC noise. Connecting the screen at each end will require that each BACnet device has the same earth potential or else an equalizing current will flow in the screen of the cable and cause disturbance and poor performance of the system. Where this is not possible, the screen can be isolated from the chassis of the drive by use of shrink-tubing. It must be pointed out that the routing of the BACnet cable must be established with a maximum distance to other cables such as mains, motor cable, etc.

How to Configure the System

Configuring BACnet

Initialization Procedure

General Settings

Name	Par. Number	Default Value	Setting for BACnet
Control Site	8-01	Digital and control word	Digital and control word
Control word source	8-02	Drive RS485	FC RS485
ControlWord Timeout time	8-03	60 sec	60 sec
ControlWord Timeout Function	8-04	Off	Off
End of Timeout Function	8-05	Resume setup	Resume setup
Reset ControlWord Timeout	8-06	Do not reset	Do not reset
Diagnosis	8-07	Disable	n.a.
Communication Charset	8-09	1025	
ControlWord Profile	8-10	Drive Profile	Drive Profile

Drive Port Settings

Name	Par. Number	Default Value	Setting for BACnet
Protocol	8-30	Drive	BACnet
Address	8-31	100	1 ¹⁾
Baud Rate	8-32	38400	9600 baud
Minimum Response Delay	8-35	10 ms	10 ms
Max Response Delay	8-36	5000 ms	5000 ms

1) The address setting is depending on the system, and each device connected to the BACnet TP must have a unique address on this TP network.

Please also see section: Parameter Overview >Parameter List.

Digital/Bus settings

Name	Par. Number	Default Value	Setting for BACnet
Coasting Select	8-50	Logic-or	Logic-or
Quick Stop Select	8-51	Logic-or	Logic-or
DC Brake Select	8-52	Logic-or	Logic-or
Start Select	8-53	Logic-or	Logic-or
Reversing Select	8-54	Logic-or	Logic-or
Set-up Select	8-55	Logic-or	Logic-or
Preset reference Select	8-56	Logic-or	Logic-or

BACnet settings

Name	Par. Number	Default Value	Setting for BACnet
BACnet device Instance	8-71	1	1 ¹⁾
TP Max Requestors	8-73	127	Dependant on the Number of Masters in the system
"I am" Service	8-74	At power up	At power up
Initialisation Password	8-75	"admin"	"admin"

1) The device instance setting is depending on the system, and each device connected to the BACnet TP must have a unique device instance in the complete system.

Control Word Time-out Function

Par. 8-03 [Control Timeout Time](#) and par. 8-04 [Control Timeout Function](#) are not enabled in this version of the BACnet option.

Example of a simple setup of BACnet

This example shows the necessary steps to set up the TR200 BACnet interface with the following system requirements:

- TP running at 38,400 Baud
- MAC address 20 for the TR200 on the TP network
- Device Instance number 1025 for the TR200
- Highest number of a Requestor device is 35
- Start/stop of Drive from BACnet only
- Reference from BACnet
- Read status of Drive (Actual speed)

Set the following parameters:

Name	Par. number	Value
Protocol	8-30	BACnet [5]
Address	8-31	20
Drive Port Baud Rate	8-32	38,400 Baud [4]
Coasting Select	8-50	Bus [1]
BACnet device Instance	8-70	1025
TP Max Requestors	8-72	35

After the parameters have been set according the table above, the drive has to be unpowered and repowered before the changes take effect. When the frequency converter is detected by the BMS, the drive can be controlled by BV:1, which will start the motor if set to [1]. Setting AV:1 will set the speed reference of the drive. The actual speed can be monitored via AV:3. See also *Analog Input- and Output Objects* section.

How to Control the Frequency Converter

Reference Handling

Select the frequency converter configuration mode in par. 1-00 [Configuration Mode](#).

- [0] Open Loop
- [3] Closed Loop

Open loop

For open loop operation, the reference represents the desired output speed of the frequency converter.
The speed reference value:

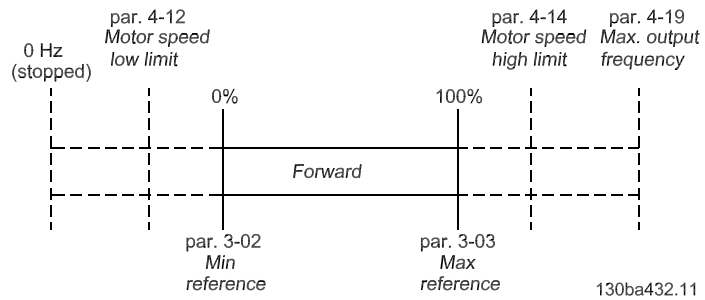

Closed loop

For closed loop operation, the reference represents the setpoint.

Note

In closed loop operation, par. 3-02 [Minimum Reference](#) and par. 4-12 [Motor Speed Low Limit \[Hz\]](#) must be set to 0 Hz. Set the par. 4-14 [Motor Speed High Limit \[Hz\]](#) to a value greater than the setting in par. 3-03 [Maximum Reference](#).

Network Frequency Converter Control Inputs and -Outputs

Analog Input- and Output Objects

Control the frequency converter from the BACnet network using 'objects'. The various types of 'objects' and their descriptions are shown in the following tables. In the following tables all available objects are shown. The availability of objects depends on the mounting of the B and/or C options.

Object ID	Object Name	Read/Write	Non volatile RAM Store	Drive Par.	Remarks
AI:1	Analog Input 53	R	No	16-62	
AI:2	Analog Input 54	R	No	16-64	
AI:3	Analog Input X30/11	R	No	16-75	If MCB 101 is installed
AI:4	Analog Input X30/12	R	No	16-76	If MCB 101 is installed
AI:8	Analog Input X49/1	R	No	18-40	If MCB 115 is installed
AI:9	Analog Input X49/3	R	No	18-41	If MCB 115 is installed
AI:10	Analog Input X49/5	R	No	18-42	If MCB 115 is installed

Table 5. 1: Analog inputs

Object ID	Object Name	Read/Write	Non volatile RAM Store	Linked to TR200 Parameter	Remarks
AO:1	Terminal 42 Output Bus Control	W/R	No	6-53	Commandable
AO:2	Analog Out X30/8 [mA]	W/R	No	6-63	If MCB 101 is installed Commandable
AO:6	Analog Output X49/7	W/R	No	36-44	If MCB 115 is installed Commandable
AO:7	Analog Output X49/9	W/R	No	36-54	If MCB 115 is installed Commandable
AO:8	Analog Output X49/11	W/R	No	36-64	If MCB 115 is installed Commandable

Table 5. 2: Analog outputs

Object ID	Object Name	Read/Write	Non volatile RAM Store	TR200 Parameter	Remarks
AV:1 ¹	Input Reference 1	W/R	No		Commandable
AV:2 ¹	Input Reference 2	W/R	No		Commandable
AV:3 ²	Output Speed	Read	No		
AV:4 ³	PID Feedback	Read	No		
AV:5	Motor Current	Read	No	16-14	
AV:6	Power [kW]	Read	No	16-10	
AV:7	kWh Counter	Read	No	15-02	
AV:8	Inverter Thermal	Read	No	16-35	
AV:11	Motor Voltage	Read	No	16-12	
AV:12	Frequency	Read	No	16-13	
AV:13	Torque [%]	Read	No	16-22	
AV:14	DC Link Voltage	Read	No	16-30	
AV:15	Motor Thermal	Read	No	16-18	
AV:16	Heatsink Temp.	Read	TR200	16-34	
AV:17	Operating Hours	Read	TR200	15-00	
AV:18	Running Hours	Read	TR200	15-01	
AV:19	Bus Feedback 1	W/R	TR200	8-94	
AV:20	Bus Feedback 2	W/R	TR200	8-95	
AV:21	Bus Feedback 3	W/R	TR200	8-96	
AV:22	PID Start Speed [Hz]	W/R	TR200	20-83	
AV:23	On Reference Bandwidth	W/R	TR200	20-84	
AV:24	PID Proportional Gain	W/R	TR200	20-93	
AV:25	PID Integral Time	W/R	TR200	20-94	
AV:26	PID Differentiation Time	W/R	N/A	20-95	
AV:27	PID Diff. Gain Limit	W/R	TR200	20-96	
AV:28	Non-requestor Messages Rcvd	Read	TR200	8-82	
AV:29	Non-requestor Error Count	Read	TR200	8-83	
AV:30	Non-requestor Messages Sent	Read	N/A	8-84	
AV:50	Alarm Log: Error Code	Read	TR200	15-30	
AV:51 ⁴	Fault Code	Read	TR200		

Table 5. 3: Analog values

¹Either AV:1 or AV:2 controls the drive reference. Only one of them can control the drive at a time and BV:2 decides which one.

²This value is not directly available in the drive. The value must be calculated as follows:

$$AV\# 3 = \frac{Par. 16 - 17}{Par. 4 - 13} \times 100\%$$

³This value is not directly available in the drive. The value must be calculated as follows:

$$AV\# 4 = \frac{Par. 16 - 52}{Par. 20 - 14} \times 100\%$$

⁴TR200 fault codes are transmitted as an analog value in AV:51. The Fault codes are mapped as shown in table on following page. The TR200 alarm codes are shown as well for comparison.

Display Text	Fault Code	TR200 Alarms	Fault Descriptions
Communication Error	1	17, 34	Loss of communication with the network
Over Current	2	13, 40, 41, 42, 59	Instantaneous Output Current has exceeded inverter rated or programmed value
Over Temperature	3	11, 29, 65, 69, 74, 244, 245, 247	Heat sink Temperature Limit has been reached
Over Speed Deviation	4	49, 62	Inverter has exceeded maximum or programmed limit
Over Voltage	5	5, 7, 64	DC Bus Voltage has exceeded inverter limit
Under Voltage	6	1, 6, 8	DC Bus Voltage is lower than required inverter limit
Short Circuit	7	16	Inverter Output has shorted Phase to Phase
Ground Fault	8	14	Inverter Output Grounding Current has exceeded manufacturer
Motor Overload	9	10, 50-58, 222	Motor is overloaded
Inverter Overload	10	9	Timed over current fault
Over Torque Detection	11	12	Programmed limit for torque has been exceeded
External Fault	12	142	External fault has been activated in the inverter. This is a hard fault that must be reset
Operator Interface Error	13	-	Inverter programming or operational interface malfunction
Load Loss	14	3, 95, 229	Load on the Motor is less than programmed limit of system. An Example is a broken belt or coupling
Configuration Error	15	70, 76, 79, 81, 82, 91	Errors exist in the programmed or operational configuration of the inverter
Feedback Failure	16	60, 90, 192	Required system operational feedback (signal or sensor) is not responding as expected for correct system operation
Output Phase Loss	17	30, 31, 32	One or more of the output phases from the inverter to the motor are open
Motor Stall	18	99	Motor is operating in stall region and not able to accelerate
Power Unit Error	19	4, 33, 36, 37, 46, 228, 246	Error sensed on the power section of the inverter
Input Phase	20	-	Input single phase or low line voltage condition
Internal Drive Failure	21	23, 27, 38, 39, 47, 48, 73, 85, 86	Manufacturer defined internal operations that have failed their self checks.

Table 5. 4: Mapping of Fault Codes

Binary Input- and Output Objects

Object Id	Object Name	Read/Write	Non volatile RAM Store	Drive Parameter	Remarks
BI:1	Digital Input 18	Read	No	16-60/05	Commandable
BI:2	Digital Input 19	Read	No	16-60/04	Commandable
BI:3	Digital Input 27	Read	No	16-60/03	Commandable
BI:4	Digital Input 29	Read	No	16-60/02	Commandable
BI:5	Digital Input 32	Read	No	16-60/01	16-60/05 Commandable
BI:6	Digital Input 33	Read	No	16-60/00	Commandable
BI:7	Digital Input 37	Read	No	16-60/06	
BI:8	Digital Input X30/2	Read	No	16-60/09	If MCB 101 is installed
BI:9	Digital Input X30/3	Read	No	16-60/08	If MCB 101 is installed
BI:10	Digital Input X30/4	Read	No	16-60/07	If MCB 101 is installed

Table 5. 5: Binary inputs

Object Id	Object Name	Read/Write	Non volatile RAM Store	Drive Parameter	Remarks
BO:1	Digital Output 27	W/R	No	5-90/00	Commandable
BO:2	Digital Output 29	W/R	No	5-90/01	Commandable
BO:3	Relay 1 Output	W/R	No	5-90/04	Commandable
BO:4	Relay 2 Output	W/R	No	5-90/05	Commandable
BO:5	GPIO Output Term X30/6	W/R	No	5-90/02	Commandable
BO:6	GPIO Output Term X30/7	W/R	No	5-90/03	Commandable
BO:7	Option B Relay 1 Output	W/R	No	5-90/06	Commandable
BO:8	Option B Relay 2 Output	W/R	No	5-90/07	Commandable
BO:9	Option B Relay 3 Output	W/R	No	5-90/08	Commandable

Table 5. 6: Binary outputs

Object ID	Object Name	Read / Write	Non volatile RAM Store	Drive Parameter	Remarks
BV:1	RUN/STOP Command	W/R	No	CTW	Commandable
BV:2	REF1 / REF2 Select	W/R	No		Commandable
BV:3	Fault Reset Command	W/R	No	CTW	
BV:4	RUN / STOP Monitor	R	No	CTW	
BV:5	OK / FAULT Monitor	R	No	CTW	
BV:6	HAND / AUTO Reference	R	No	16-95	
BV:7	Running	R	No	STW	
BV:8	Coast	R/W	No	STW	Commandable
BV:9	Reverse	R/W	No	STW	Commandable
BV:10	Jog	R/W	No	STW	Commandable
BV:11	Ramp 1/Ramp 2	R/W	No	STW	Commandable
BV:12	Warning	R	No	STW	
BV:13	Trip	R	No	STW	
BV:14	Triplock	R	No	STW	
BV:15	Reset KWh Counter	R/W	No	15-06	
BV:16	Reset Running Hours Counter	R/W	No	15-07	
BV:17	At Reference	R	No	STW	
BV:18	ECB Test Mode	R	No	31-10/00	If MCO 104 is installed
BV:19	ECB Drivemode	R	No	31-10/01	If MCO 104 is installed
BV:20	ECB Automatic bypass mode	R	No	31-10/02	If MCO 104 is installed
BV:21	Bypass Mode	R	No	31-10/03	If MCO 104 is installed
BV:22	Reset Non-Requestor msg Recv	R/W	No	8-82	
BV:23	Reset Non-Requestor error Count	R/W	No	8-83	
BV:24	Reset Non-Requestor msg Sent	R/W	No	8-83	

Table 5. 7: Binary values

Multi-state Value Objects

Object Id	Object Name	Read/Write	Changeable Description	Drive Parameter	Remarks
MSV:1	Active Setup	W/R	No	Bit13&14 in CTW	
MSV:2	Smart Logic Controller Stage	R	No	16-38	
MSV:3	Bypass Mode	W/R	No	31-00	If MCO 104 is installed

Real Time Clock Variable

The frequency converter has a built-in real-time clock. The standard real-time clock has no battery backup function, which will lead to a loss of time if the drive is un-powered. Some BACnet Master's can be programmed to send out the date and time as a time sync service telegram on a regular basis. The BACnet Interface will update the real-time clock of the drive if it receives the time synchronization telegram.

Drive Feedback to Network

The BACnet interface provides several objects to the network, containing important drive -, motor- and I/O feedback data.

Influence of the digital input terminals upon the Drive Control Mode, par. 8-50 [Coasting Select](#) to par. 8-56 [Preset Reference Select](#)

The influence of the digital input terminals upon control of the frequency converter can be programmed in par. 8-50 [Coasting Select](#) to par. 8-56 [Preset Reference Select](#).

Note

Par. 8-01 [Control Site](#) overrules the settings in *parameters 8-50 to 8-56* and Terminal 37, Safe Stop overrules any parameter.

Each of the digital input signals can be programmed to logic AND, logic OR, or to have no relation to the corresponding bit in the control word. In this way a specific control command i.e. stop / coast, can be initiated by the fieldbus only, fieldbus AND Digital Input, or Fieldbus OR Digital input terminal.

Note

In order to control the frequency converter via BACnet, par. 8-50 [Coasting Select](#) must be set to either Bus [1], or to Logic AND [2] and par. 8-01 [Control Site](#) must be set to Digital and ctrl. word [0] or Controlword only [2].

BIBBs

ReadProperty	Execute
WriteProperty	Execute
DeviceCommunicationControl	Execute
ReinitializeDevice	Execute
I-Am	Initiate
I-Have	Initiate
TimeSynchronization	Execute
Who-Has	Execute
Who-Is	Execute

Object / Property Support Matrix

The following table summarizes the Object Types and Properties supported:

Property	Device	Binary input	Binary output	Binary value	Analog input	Analog output	Analog value	Multi-stage value
Object identifier	X	X	X	X	X	X	X	X
Object Name	X	X	X	X	X	X	X	X
Object Type	X	X	X	X	X	X	X	X
System Status	X							
Vendor Name	X							
Vendor Identifier	X							
Model Name	X							
Firmware Revision	X							
Appl. Software Revision	X							
Location	X							
Description	X							
Protocol Version	X							
Protocol Revision	X							
Services Supported	X							
Object List	X							
Max. APDU Length	X							
Segmentation Support	X							
Local Time	X							
Local Date	X							
APDU Timeout	X							
Number APDU Retries	X							
Max Requestor	X							
Max Info Frames	X							
Device Address Binding	X							
Database Revision	X							
Present Value		X	X	X	X	X	X	X
Status Flags		X	X	X	X	X	X	X
Event State		X	X	X	X	X	X	X
Reliability		X	X	X	X	X	X	X
Out-of-Service		X	X	X	X	X	X	X
Number of States								X
State Text								X
Units					X	X	X	
Priority Array			X	X*		X	X*	X*
Relinquish Default			X	X*		X	X*	X*
Polarity		X	X					
Active Text		X	X	X				
Inactive Text		X	X	X				

*For commandable values only

Parameters

Parameter Overview

Parameter List

Nr.	Title	Default value	Range	Conversion index	Data type
8-01	Control Site	Dig. and ctrl. word [0]	[0 - 2]	-	5
8-02	Control Source	Option A	[0 - 4]	-	5
8-03	Control Timeout Time	1 s	0.1 - 18000	- 1	7
8-04	Control Timeout Function	Off [0]	[0 - 10]	-	5
8-05	End-of-timeout Function	Hold set-up [0]	[0 - 1]	-	5
8-06	Reset Control Timeout	Do not reset [0]	[0 - 1]	-	5
8-07	Diagnosis Trigger	Disable [0]	[0 - 3]	-	5
8-10	Control Profile	Drive profile [0]	[0 - x]	-	5
8-30	Protocol	Drive			
8-31	Address	1	[0 - 255]		
8-32	Baudrate	38,400	[0 - 7]		
8-33	Parity/Stop Bits	No Parity, 1 Stop Bit			
8-35	Minimum Response Delay	10mS			
8-36	Max Response Delay	5000mS			
8-37	Max Inter-Char Delay	25.00mS			
8-50	Coasting Select	Logic OR [3]	[0 - 3]	-	5
8-52	DC Brake Select	Logic OR [3]	[0 - 3]	-	5
8-53	Start Select	Logic OR [3]	[0 - 3]	-	5
8-54	Reversing Select	Logic OR [3]	[0 - 3]	-	5
8-55	Setup Select	Logic OR [3]	[0 - 3]	-	5
8-56	Preset Reference Select	Logic OR [3]	[0 - 3]	-	5
8-70	BACnet Device Instance	1	[1-4194304]	-	
8-72	TP Max Requestors	127	[1-127]	-	
8-73	TP Max Info Frames				
8-74	"I am" Service	Once at powerup [0]	[0-1]	-	
8-75	Initialization Password	"admin"	String[19]		

Table 6. 1: BACnet specific parameter list

Please refer to the *TR200 Drive Operating Instructions, MG.12.HX.YY* for a comprehensive parameter list or to the *TR200 Drive Programming Guide, MG.12.JX.YY* for detailed descriptions of parameters.

Conversion index

This number refers to a conversion figure used when writing or reading to and from the frequency converter.

Conv. index	100	67	6	5	4	3	2	1	0	-1	-2	-3	-4	-5	-6
Conv. factor	1	1/60	1000000	100000	1000	1000	100	10	1	0.1	0.01	0.001	0.0001	0.00001	0.00000
					0										1

Data type	Description	Type
2	Integer 8	Int8
3	Integer 16	Int16
4	Integer 32	Int32
5	Unsigned 8	UInt8
6	Unsigned 16	UInt16
7	Unsigned 32	UInt32
9	Visible String	VisStr
33	Normalized value 2 bytes	N2
35	Bit sequence of 16 boolean variables	V2
54	Time difference w/o date	TimD

See the frequency converter *Design Guide* for further information about data types 33, 35 and 54.

Parameter Description

8-** Comm. and Options

Parameter group for configuring communications and options.

8-01 Control Site

Option:

Function:

The setting in this parameter overrides the settings in par. 8-50 [Coasting Select](#) to par. 8-56 [Preset Reference Select](#).

[0] *	Digital and ctrl.word	Control by using both digital input and control word.
[1]	Digital only	Control by using digital inputs only.
[2]	Controlword only	Control by using control word only.

8-02 Control Source

Option:

Function:

Select the source of the control word: one of two serial interfaces or four installed options. During initial power-up, the frequency converter automatically sets this parameter to *Option A* [3] if it detects a valid fieldbus option installed in slot A. If the option is removed, the frequency converter detects a change in the configuration, sets par. 8-02 [Control Source](#) back to default setting *FC Port*, and the frequency converter then trips. If an option is installed after initial power-up, the setting of par. 8-02 [Control Source](#) will not change but the frequency converter will trip and display: Alarm 67 *Option Changed*.

[0]	None
[1]	FC Port
[2] *	USB Port
[3]	Option A
[4]	Option B

NOTE: This parameter cannot be adjusted while the motor is running.

8-03 Control Timeout Time

Range:

Application dependent*
 [1.0 - 18000.0 s]

Function:

Enter the maximum time expected to pass between the reception of two consecutive telegrams. If this time is exceeded, it indicates that the serial communication has stopped. The function selected in par. 8-04 [Control Timeout Function](#) *Control Time-out Function* will then be carried out.

In BACnet the control timeout is only triggered if some specific objects are written. The object list hold information on the objects that triggers the control timeout:

- Analog Outputs
- Binary Outputs
- AV0
- AV1
- AV2
- AV4
- BV1
- BV2
- BV3
- BV4
- BV5
- Multistate Outputs

8-04 Control Timeout Function

Option:

Function:

Select the time-out function. The time-out function is activated when the control word fails to be updated within the time period specified in par. 8-03 [Control Timeout Time](#). Choice [20] only appears after setting the Metasys N2 protocol.

- [0] * Off
- [1] Freeze output
- [2] Stop
- [3] Jogging
- [4] Max. speed
- [5] Stop and trip
- [7] Select setup 1
- [8] Select setup 2
- [9] Select setup 3
- [10] Select setup 4
- [20] N2 Override Release

8-05 End-of-Timeout Function

Option:
Function:

Select the action after receiving a valid control word following a time-out. This parameter is active only when par. 8-04 [Control Timeout Function](#) is set to [Set-up 1-4].

[0] Hold set-up

Retains the set-up selected in par. 8-04 [Control Timeout Function](#) and displays a warning, until par. 8-06 [Reset Control Timeout](#) toggles. Then the frequency converter resumes its original set-up.

[1] * Resume set-up

Resumes the set-up active prior to the time-out.

8-06 Reset Control Timeout

Option:
Function:

This parameter is active only when the choice *Hold set-up* [0] has been selected in par. 8-05 [End-of-Timeout Function](#).

[0] * Do not reset

Retains the set-up specified in par. 8-04 [Control Timeout Function](#), [Select setup 1-4] following a control time-out.

[1] Do reset

Returns the frequency converter to the original set-up following a control word time-out. When the value is set to *Do reset* [1], the frequency converter performs the reset and then immediately reverts to the *Do not reset* [0] setting.

8-07 Diagnosis Trigger

Option:
Function:

This parameter has no function for BACnet.

[0] * Disable

[1] Trigger on alarms

[2] Trigger alarm/warn.

8-09 Communication Charset

Option:
Function:

[0] * ISO 8859-1

[1] ANSI X3.4

8-30 Protocol

Option:
Function:

[5] BACnet

Communication according to the BACnet protocol as described in TR200 Embedded BACnet Operating Instructions.

8-31 Address

Range:
Function:

1. * [1. - 127.]

8-32 Baud Rate

Option:

Function:

Baud rate selection depends on Protocol selection in par. 8-30 [Protocol](#).

[2] 9600 Baud

[3] 19200 Baud

[4] * 38400 Baud

[6] 76800 Baud

Default refers to the FC Protocol.

8-33 Parity / Stop Bits

Option:

Function:

Parity and Stop Bits for the protocol par. 8-30 [Protocol](#) using the Drive Port. For some of the protocols, not all options will be visible. Default depends on the protocol selected.

[0] * Even Parity, 1 Stop Bit

[1] Odd Parity, 1 Stop Bit

[2] No Parity, 1 Stop Bit

[3] No Parity, 2 Stop Bits

8-35 Minimum Response Delay

Range:

Function:

Applica- [Application dependant]
tion de-
pend-
ent*

Specify the minimum delay time between receiving a request and transmitting a response. This is used for overcoming modem turnaround delays.

8-36 Maximum Response Delay

Range:

Function:

Applica- [Application dependant]
tion de-
pend-
ent*

Specify the maximum permissible delay time between transmitting a request and receiving a response. Exceeding this delay time will cause control word time-out.

8-37 Maximum Inter-Char Delay

Range:

Function:

Applica- [Application dependant]
tion de-
pend-
ent*

Specify the maximum permissible time interval between receipt of two bytes. This parameter activates time-out if transmission is interrupted.

8-50 Coasting Select

Option:	Function:
	Select control of the coasting function via the terminals (digital input) and/or via the bus.
[0] Digital input	Activates Start command via a digital input.
[1] Bus	Activates Start command via the serial communication port or fieldbus option.
[2] Logic AND	Activates Start command via the fieldbus/serial communication port, AND additionally via one of the digital inputs.
[3] * Logic OR	Activates Start command via the fieldbus/serial communication port OR via one of the digital inputs.

8-52 DC Brake Select

Option:	Function:
	Select control of the DC brake via the terminals (digital input) and/or via the fieldbus.
[0] Digital input	Activates Start command via a digital input.
[1] Bus	Activates Start command via the serial communication port or fieldbus option.
[2] Logic AND	Activates Start command via the fieldbus/serial communication port, AND additionally via one of the digital inputs.
[3] * Logic OR	Activates Start command via the fieldbus/serial communication port OR via one of the digital inputs.

8-53 Start Select

Option:	Function:
	Select control of the frequency converter start function via the terminals (digital input) and/or via the fieldbus.
[0] Digital input	Activates Start command via a digital input.
[1] Bus	Activates Start command via the serial communication port or fieldbus option.
[2] Logic AND	Activates Start command via the fieldbus/serial communication port, AND additionally via one of the digital inputs.
[3] * Logic OR	Activates Start command via the fieldbus/serial communication port OR via one of the digital inputs.

8-54 Reversing Select

Option:	Function:
	Select control of the frequency converter reverse function via the terminals (digital input) and/or via the fieldbus.
[0] * Digital input	Activates Reverse command via a digital input.
[1] Bus	Activates Reverse command via the serial communication port or fieldbus option.
[2] Logic AND	Activates Reverse command via the fieldbus/serial communication port, AND additionally via one of the digital inputs.
[3] Logic OR	Activates Reverse command via the fieldbus/serial communication port OR via one of the digital inputs.

NOTICE

This parameter is active only when par. 8-01 [Control Site](#) is set to [0] *Digital and control word*.

8-55 Set-up Select

Option:	Function:
	Select control of the frequency converter set-up selection via the terminals (digital input) and/or via the fieldbus.
[0] Digital input	Activates the set-up selection via a digital input.
[1] Bus	Activates the set-up selection via the serial communication port or fieldbus option.
[2] Logic AND	Activates the set-up selection via the fieldbus/serial communication port, AND additionally via one of the digital inputs.
[3] * Logic OR	Activate the set-up selection via the fieldbus/serial communication port OR via one of the digital inputs.

8-56 Preset Reference Select

Option:	Function:
	Select control of the frequency converter Preset Reference selection via the terminals (digital input) and/or via the fieldbus.
[0] Digital input	Activates Preset Reference selection via a digital input.
[1] Bus	Activates Preset Reference selection via the serial communication port or fieldbus option.
[2] Logic AND	Activates Preset Reference selection via the fieldbus/serial communication port, AND additionally via one of the digital inputs.
[3] * Logic OR	Activates the Preset Reference selection via the fieldbus/serial communication port OR via one of the digital inputs.

8-70 BACnet Device Instance

Range:	Function:
0 - 4194302	The Device Instance number must be unique for the complete BACnet, not only for this TP Branch.
1 * [0 - 4194302]	Enter a unique ID number for the BACnet device.

8-72 TP Max Masters

Range:	Function:
0 - 127	Define the address of the requestor which holds the highest address in this network. Decreasing this value optimizes polling for the token.
127 * [0 - 127]	Define the address of the requestor which holds the highest address in this network. Decreasing this value optimizes polling for the token.

8-73 TP Max Info Frames

Range:	Function:
1 - 65534	Define how many info/data frames the device is allowed to send while holding the token.
1 * [1 - 65534]	Define how many info/data frames the device is allowed to send while holding the token.

8-74 "I-Am" Service

Option:	Function:
[0] * Send at power-up	
[1] Continuously	Choose whether the device should send the "I-Am" service message only at power-up or continuously with an interval of approx. 1 min.

8-75 Initialisation Password

Range:	Function:
[Size 0 - 0 related]	Enter the password needed for execution of Drive Re-initialisation from BACnet.
0 * [0 - 0]	Enter the password needed for execution of Drive Re-initialisation from BACnet.

Troubleshooting

Alarm, Warning and Extended Status Word

Alarm and Warning Messages

General

There is a clear distinction between alarms and warnings. In the event of an alarm, the frequency converter will enter a fault condition. After the cause for the alarm has been cleared, the requestor must acknowledge the alarm message in order to start operation of the frequency converter again. A warning, on the other hand, may appear when a warning condition arises, then disappear when conditions return to normal without interfering with the process.

Alarm Word and Warning Word are shown on the display in Hex format. If there is more than one warning or alarm, a sum of all warnings or alarms will be shown. Warning Word and Alarm Word are displayed in par. 16-90 to 16-95. For more information on the individual alarms and warnings, please refer to: *TR200 Design Guide*.

Warnings

All warnings within the frequency converter are represented by a single bit within a Warning Word. A Warning Word is always an action parameter. Bit status FALSE [0] means no warning, while bit status TRUE [1] means warning. Each bit status has a corresponding text string message. In addition to the Warning Word message the requestor will also be notified via a change to bit 7 in the status word.

Alarms

Following an alarm message the frequency converter will enter a fault condition. Only after the fault has been rectified and the requestor has acknowledged the alarm message by setting bit 3 in the Control Word, can the FC resume operation. All alarms within the TR200 are represented by a single bit within an Alarm Word. An Alarm Word is always an action parameter. Bit status FALSE [0] means no alarm, while bit status TRUE [1] means alarm.

Alarm Words

 Alarm word, par. 16-90 [Alarm Word](#)

Bit (Hex)	Alarm Word (par. 16-90 Alarm Word)
00000001	Brake check
00000002	Power card over temperature
00000004	Earth fault
00000008	Ctrl. card over temperature
00000010	Control word timeout
00000020	Over current
00000040	Torque limit
00000080	Motor thermistor over temp.
00000100	Motor ETR over temperature
00000200	Inverter overloaded
00000400	DC link under voltage
00000800	DC link over voltage
00001000	Short circuit
00002000	Inrush fault
00004000	Mains phase loss
00008000	AMA not OK
00010000	Live zero error
00020000	Internal fault
00040000	Brake overload
00080000	Motor phase U is missing
00100000	Motor phase V is missing
00200000	Motor phase W is missing
00400000	Fieldbus fault
00800000	24V supply fault
01000000	Mains failure
02000000	1.8V supply fault
04000000	Brake resistor short circuit
08000000	Brake chopper fault
10000000	Option change
20000000	Drive initialised
40000000	Safe Stop
80000000	Not used

 Alarm word 2, par. 16-91 [Alarm Word 2](#)

Bit (Hex)	Alarm Word 2 (par. 16-91 Alarm Word 2)
00000001	Service Trip, read / Write
00000002	Reserved
00000004	Service Trip, Typecode / Sparepart
00000008	Reserved
00000010	Reserved
00000020	No Flow
00000040	Dry Pump
00000080	End of Curve
00000100	Broken Belt
00000200	Not used
00000400	Not used
00000800	Reserved
00001000	Reserved
00002000	Reserved
00004000	Reserved
00008000	Reserved
00010000	Reserved
00020000	Not used
00040000	Fans error
00080000	ECB error
00100000	Reserved
00200000	Reserved
00400000	Reserved
00800000	Reserved
01000000	Reserved
02000000	Reserved
04000000	Reserved
08000000	Reserved
10000000	Reserved
20000000	Reserved
40000000	Reserved
80000000	Reserved

Warning Words

Warning word, par. 16-92 [Warning Word](#)

Bit (Hex)	Warning Word (par. 16-92 Warning Word)
00000001	Brake check
00000002	Power card over temperature
00000004	Earth fault
00000008	Ctrl. card over temperature
00000010	Control word timeout
00000020	Over current
00000040	Torque limit
00000080	Motor thermistor over temp.
00000100	Motor ETR over temperature
00000200	Inverter overloaded
00000400	DC link under voltage
00000800	DC link over voltage
00001000	DC link voltage low
00002000	DC link voltage high
00004000	Mains phase loss
00008000	No motor
00010000	Live zero error
00020000	10V low
00040000	Brake resistor power limit
00080000	Brake resistor short circuit
00100000	Brake chopper fault
00200000	Speed limit
00400000	Fieldbus comm. fault
00800000	24V supply fault
01000000	Mains failure
02000000	Current limit
04000000	Low temperature
08000000	Voltage limit
10000000	Encoder loss
20000000	Output frequency limit
40000000	Not used
80000000	Not used

Warning word 2, par. 16-93 [Warning Word 2](#)

Bit (Hex)	Warning Word 2 (par. 16-93 Warning Word 2)
00000001	Start Delayed
00000002	Stop Delayed
00000004	Clock Failure
00000008	Reserved
00000010	Reserved
00000020	No Flow
00000040	Dry Pump
00000080	End of Curve
00000100	Broken Belt
00000200	Not used
00000400	Reserved
00000800	Reserved
00001000	Reserved
00002000	Reserved
00004000	Reserved
00008000	Reserved
00010000	Reserved
00020000	Not used
00040000	Fans warning
00080000	ECB warning
00100000	Reserved
00200000	Reserved
00400000	Reserved
00800000	Reserved
01000000	Reserved
02000000	Reserved
04000000	Reserved
08000000	Reserved
10000000	Reserved
20000000	Reserved
40000000	Reserved
80000000	Reserved

Index

"

"i-am" Service 8-74.....30

A

Abbreviations7
 Alarm And Warning Messages31
 Alarm Word32
 American National Standard6
 Analog Input- And Output Objects16
 Assumptions6

B

Background Knowledge7
 Bacnet (building Automation And Control Network)6
 Bacnet Cable11
 Bacnet Settings13
 Bacnet Specific Parameter List23
 Bibb's21
 Binary Input- And Output Objects19

C

Cable Lengths And Number Of Nodes8
 Cable Routing11
 Cabling8
 Coasting Select 8-50.....28
 Communication Cable11
 Control Site 8-01.....24
 Control Timeout Function 8-04.....25
 Control Timeout Time 8-03.....25
 Control Word Time-out Function14
 Copyright, Limitation Of Liability And Revision Rights2

D

Dc Brake Select 8-52.....28
 Diagnosis Trigger 8-07.....26
 Digital/bus Settings13
 Drive Feedback To Network21
 Drive Port Settings13

E

Electrical Ratings5
 Emc Precautions12
 End-of-timeout Function 8-05.....26

G

General Settings13

I

Initialization Procedure13

L

Literature7

M

Maximum Inter-char Delay 8-37.....27
 Maximum Response Delay 8-36.....27
 Minimum Response Delay 8-35.....27
 Multiple Ground Shielding12
 Multi-state Value Objects20

N

Network Connection	8
Network Frequency Converter Control Inputs And -outputs	16
Network Termination	9

O

Object / Property Support Matrix	22
--	----

P

Parameter List	23
Parity / Stop Bits 8-33.....	27
Preset Reference Select 8-56.....	29

R

Real Time Clock Variable	20
Reference Handling	15
Reset Control Timeout 8-06.....	26
Reversing Select 8-54.....	29

S

Safety Note	4
Safety Regulations	4
Setup Example	14
Set-up Select 8-55.....	29
Single Ground Shielding	12
Start Select 8-53.....	28
Switches S201, S202, And S801	10

T

Technical Overview	6
--------------------------	---

W

Warning Against Unintended Start	4
Warning Word	33
Warning Word 2	33

Trane - by Trane Technologies (NYSE: TT), a global climate innovator - creates comfortable, energy efficient indoor environments for commercial and residential applications. For more information, please visit trane.com or tranetechnologies.com.

Trane has a policy of continuous product and product data improvement and reserves the right to change design and specifications without notice. We are committed to using environmentally conscious print practices.