



# Instruction Manual



## SAFETY WARNING

Only qualified personnel should install and service the equipment. The installation, starting up, and servicing of heating, ventilating, and air-conditioning equipment can be hazardous and requires specific knowledge and training. Improperly installed, adjusted or altered equipment by an unqualified person could result in death or serious injury. When working on the equipment, observe all precautions in the literature and on the tags, stickers, and labels that are attached to the equipment.

## Contents

<b>1 Introduction</b>	<b>4</b>
1.1 Introduction to Compressor Drive Systems	4
1.1.1 Sequence of Operation	5
<b>2 Safety Instructions and General Warnings</b>	<b>6</b>
2.1 Safety and Warnings	6
2.1.1 High Voltage Warning	6
2.1.2 Caution	6
2.1.3 Disposal	6
2.1.4 Software Version	6
2.1.5 Safety Instructions	6
2.1.6 General Warning	6
2.1.7 Leakage Current	7
2.1.8 Residual Current Device	7
2.1.9 IT Mains	7
2.1.10 Avoid Unintended Start	7
2.2 Safe Torque Off	7
2.2.1 Terminal 37 Safe Torque Off Function	8
<b>3 How to Install</b>	<b>10</b>
3.1 Environment	10
3.1.1 Ambient Temperature and Altitude	10
3.1.2 Environmental Requirements for Mechanical Installation	10
3.2 Mechanical Installation	10
3.2.1 Accessory Bags	10
3.2.2 Mechanical Mounting	11
3.2.3 Mechanical Dimensions	12
3.3 Electrical Installation	13
3.3.1 Cables General	13
3.3.2 Removal of Knockouts for Extra Cables	13
3.3.3 Mains Connection for B1, B2 and B3	13
3.3.4 Mains connection for B4, C1 and C3	15
3.3.5 Motor Compressor Connection	16
3.3.6 Motor Compressors Cables	16
3.3.7 Electrical Installation of Motor Compressor Cables	17
3.3.8 Compressor Motor Protection	17
3.3.9 Access to Control Terminals	17
3.3.10 Basic Wiring Example	19
3.3.11 Electrical Installation, Control Cables	20
3.3.12 Electrical Installation - EMC Protection	22

3.3.13 Motor Thermal Protection	23
3.3.14 Safety Earth Connection	23
3.3.15 Basic Examples of Control Connections	24
3.3.16 High-voltage Test	25
3.4 Fuses and Circuit Breakers	25
3.4.1 Fuses	25
3.4.2 Recommendations	25
3.4.3 CE Compliance	26
3.4.4 Non UL Compliance Fuses	26
<b>4 Quick Set-up</b>	<b>28</b>
4.1 Programming Procedures	28
4.1.1 Basic Programming Procedures	28
4.1.2 Open Loop with External Reference	28
4.1.3 PID Closed Loop with 4-20 mA Pressure Transmitter	28
4.1.4 Other Compressor Features	30
<b>5 How to Program</b>	<b>31</b>
5.1 How to Program on the Graphical Keypad	31
5.1.1 Control Panel	31
5.1.2 Display Lines	31
5.1.3 Display Contrast Adjustment	31
5.1.4	31
5.1.5 Indicator Lights	32
5.2 Keypad	32
5.2.1 Function Keys	32
5.2.2 Navigation Keys	32
5.2.3 Local Control Keys	32
5.2.4 Quick Transfer of Parameter Settings	33
5.2.5 Data Storage in Keypad	33
5.2.6 Initialisation to Default Settings	33
5.2.7 Data Transfer from Keypad to Frequency Converter	34
5.2.8 Parameter Selection	34
5.2.9 Changing Data	34
5.2.10 Changing a Text Value	34
5.2.11 Changing a Group of Numeric Data Values	35
<b>6 Parameter Descriptions</b>	<b>36</b>
6.1 Keypad Display	36
6.1.1 Keypad Programming	36
6.2 Parameters: 0-** Operation and Display	36

6.3 Parameters: 1-** Load and Motor	43
6.4 Parameters: 3-** Reference/Ramps	44
6.5 Parameters: 4-** Limits/Warnings	48
6.6 Parameters: 5-** Digital In/Out	51
6.7 Parameters: 6-** Analog In/Out	61
6.8 Parameters: 7-** Controllers	65
6.9 Parameters: 8-** Communications and Options	70
6.10 Parameters: 13-** Smart Logic Control	74
6.11 Parameters: 14-** Special Functions	92
6.12 Parameters: 15-** Drive Information	95
6.13 Parameters: 16-** Data Readouts	96
6.14 Parameters: 25-** Cascade Controller	101
6.15 Parameters: 28-** Compressor Functions	112
6.16 Parameter Lists	116
6.16.1 Default Settings	116
6.16.2 Conversion	116
<b>7 Troubleshooting</b>	<b>134</b>
7.1 Status Messages	134
7.1.1 Warnings/Alarm Messages	134
<b>8 General Specifications</b>	<b>146</b>
8.1 Power-dependent Specifications	146
8.1.1 Mains Supply 3x200-240 V AC	146
8.1.2 Mains Supply 3x380-480 V AC	147
8.1.3 Mains Supply 3x525-600 V AC	148
8.2 General Technical Data	149
<b>Index</b>	<b>153</b>

# 1 Introduction

## 1.1 Introduction to Compressor Drive Systems

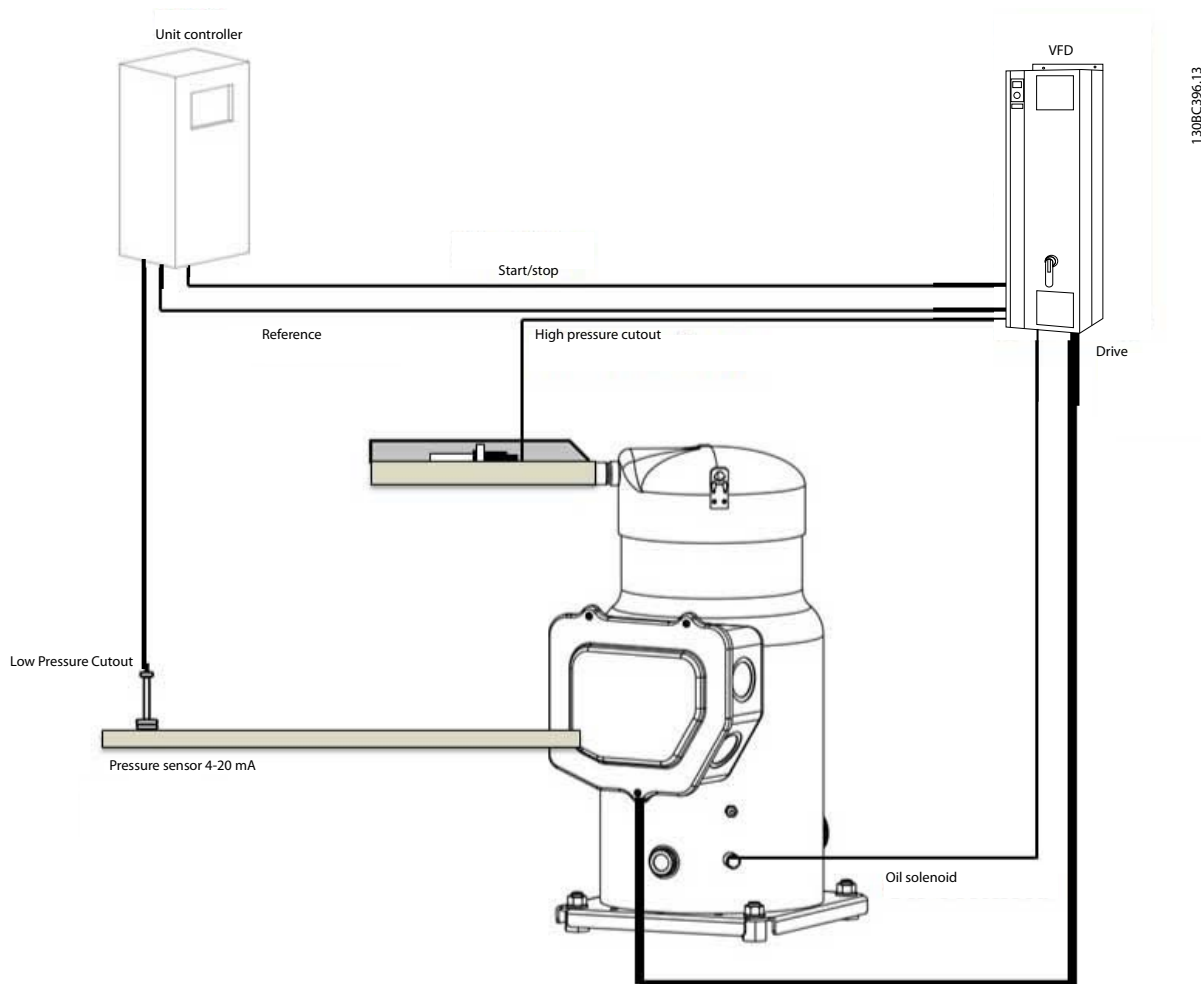

Illustration 1.1 Compressor Drive System

The TRV200 Compressor Drives utilise and combine Trane design and manufacturing expertise. Our extensive application knowledge of refrigeration, air conditioning, and motion controls ensures an optimised product design and package solution:

- A “plug & play” solution
- Operational efficiency
- Flexible and high control accuracy
- Innovative and reliable solution

The frequency converter is 100% pre-set for speed open loop configuration with 0-10 V reference corresponding to 1500-6000 RPM for TRV200.

The dedicated frequency converter functionality includes:

- **Start Up**  
Once the frequency converter has a start command, the compressor runs up to 3000 RPM and remains at that speed for 10 s. Once this initial time is complete, the frequency converter slowly ramps to the reference speed.
- **Shut Down**  
The stop command bypasses the normal ramp time and the frequency converter ramps the compressor to stop fast.
- **Short Cycle Prevention**  
The frequency converter has a minimum running time of 12 s, with an interval between starts of 5 minutes (300 s). The short cycle delay values are adjustable in parameter group 28-0\* *Short Cycle Protection*.

---

## Introduction

---

- **Oil Injection**  
The frequency converter cycles a solenoid valve via its relay 1. This cycling ensures that the oil is distributed to the scroll set, improves tightness, and reduces internal gas leakage during the compression process.
- **Low Pressure Switch**  
An LP switch is mandatory with the frequency converter compressor in any type of application.
- **High Pressure Switch**  
The high-pressure switch must be connected to input terminal 37 of the frequency converter.

### 1.1.1 Sequence of Operation

All compressor types have strong demands on speed limits to ensure the oil lubrication of the bearings. Therefore, fast acceleration from standstill to minimum speed with a special start ramp is important, when a start command is given. This is also the reason why the Compressor Drive trips with an alarm [A49] *Speed Limit*, if the speed falls below minimum speed e.g. when the current limit controller reduces the speed due to a high load. This alarm is reset automatically after 30 s and the compressor restarts.

If a rotor is blocked, the Compressor Drive trips with an alarm [A18] *Start failed*, if the speed fails to get above the minimum speed limit for the compressor within 2 s. This alarm is reset automatically after 30 s and the compressor restarts.

#### **NOTICE**

**No manual programming is required by end user.**

Trane automatically selects the necessary start settings, motor data and all the other preferred settings based off the compressor type/size. The compressor is selected in *1-13 Compressor Selection* (preset by manufacturer).

2

## 2 Safety Instructions and General Warnings

### 2.1 Safety and Warnings

#### 2.1.1 High Voltage Warning

##### **⚠ WARNING**

The voltage of the frequency converter is dangerous whenever the converter is connected to mains. Incorrect fitting of the motor or frequency converter may damage the equipment, or cause serious injury, or death. It is essential to comply with the instructions in this manual as well as local and national rules and safety regulations.

##### **⚠ WARNING**

Installation in high altitudes:  
By altitudes above 2 km, contact Trane regarding PELV.

#### 2.1.2 Caution

##### **⚠ CAUTION**

The TRV200 Compressor Drives DC link capacitors remain charged after power has been disconnected. To avoid an electrical shock hazard, disconnect the frequency converter from the mains before carrying out maintenance. Wait at least 15 minutes before doing service on the frequency converter. High voltage can be present on the DC link even when the LEDs are turned off.

#### 2.1.3 Disposal



Illustration 2.1 Disposal Symbol

##### Drive





Do not dispose of equipment containing electrical components together with domestic waste. It must be collected separately with Electrical and Electronic Waste according to local and national legislation.

##### Compressors

Do not to throw away a used compressor, but dispose of it and its oil at a specialised recycling company site.

#### 2.1.4 Software Version

TRV200 Operating Instructions Software version: 1.0x

These Operating Instructions can be used for all TRV200 Compressor Drives® with software version 1.0x. The software version number can be read in 15-43 Software Version.

The frequency converter complies with UL508C thermal memory retention requirements. For more information refer to *chapter 3.3.13 Motor Thermal Protection*.

#### 2.1.5 Safety Instructions

- Make sure that the frequency converter is properly connected to earthSafety instruction
- Do not remove mains plugs or motor plugs while the frequency converter is connected to mains
- Protect personnel against supply voltage
- Protect the motor against overloading according to local and national regulations
- Motor overload protection is included in the default settings
- The earth leakage current exceeds 3.5 mA
- The [Off] key is not a safety switch. It does not disconnect the frequency converter from mains

#### 2.1.6 General Warning

##### **⚠ WARNING**

Warning:

Touching the electrical parts may be fatal - even after the equipment has been disconnected from mains. Also make sure that other voltage inputs have been disconnected, such as load-sharing (linkage of DC intermediate circuit).

Wait at least 15 minutes before doing service on the frequency converter. High voltage can be present on the DC link even when the LEDs are turned off.

### 2.1.7 Leakage Current

#### **CAUTION**

The earth leakage current from the frequency converter exceeds 3.5 mA. Ensure good mechanical earth connection (terminal 95) to the earth cable. Use at least 10 mm<sup>2</sup> cable cross section or 2 times rated earth wires terminated separately. Leakage current

### 2.1.8 Residual Current Device

#### **CAUTION**

This product can cause a DC current in the protective conductor. Where a residual current device (RCD) is used for extra protection, only use an RCD of Type B (time delayed) on the supply side of this product. See also *RCD Application Note, MN90G*. Protective earthing of the frequency converter and the use of RCDs must always follow local and national regulations.

### 2.1.9 IT Mains

#### **CAUTION**

Do not connect 400 V frequency converters with RFI filters to mains supplies with a voltage between phase and earth of more than 440 V. For IT mains and delta earth (grounded leg), mains voltage may exceed 440 V between phase and earth. To disconnect the internal RFI capacitors from the RFI filter to earth, use *14-50 RFI 1* on the frequency converter. This procedure reduces the RFI performance to A2 level.

### 2.1.10 Avoid Unintended Start

While the frequency converter is connected to mains, the motor can be started/stopped using:

- digital commands
- bus commands
- references
- via the keypad

Disconnect the frequency converter from mains whenever personal safety considerations make it necessary to avoid unintended start. To avoid unintended start, always press [OFF] before changing parameters. An electronic fault, temporary overload, a fault in the mains supply, or lost motor connection may cause a stopped motor to start. A frequency converter with Safe Torque Off provides a certain degree of protection against such unintended start, if the Safe Torque Off Terminal 37 is on low voltage level or disconnected.

## 2.2 Safe Torque Off

The frequency converter can perform the safety function *Safe Torque Off* (STO, as defined by EN IEC 61800-5-2<sup>1</sup>) and *Stop Category 0* (as defined in EN 60204-1<sup>2</sup>).

Before integration and use of Safe Torque Off in an installation, perform a thorough risk analysis to determine whether the Safe Torque Off functionality and safety levels are appropriate and sufficient. Safe Torque Off is designed and approved suitable for the requirements of:

- Safety Category 3 in EN 954-1 (and EN ISO 13849-1)
- Performance Level "d" in EN ISO 13849-1:2008
- SIL 2 Capability in IEC 61508 and EN 61800-5-2
- SILCL 2 in EN 62061

<sup>1</sup>) Refer to EN IEC 61800-5-2 for details of Safe torque off (STO) function.

<sup>2</sup>) Refer to EN IEC 60204-1 for details of stop category 0 and 1.

#### Activation and Termination of Safe Torque Off

The Safe Torque Off (STO) function is activated by removing the voltage at terminal 37 of the safe inverter. By connecting the safe inverter to external safety devices providing a safe delay, an installation for a Safe Torque Off Category 1 can be obtained. The Safe Torque Off function can be used for asynchronous, synchronous, and permanent magnet motors.

#### **WARNING**

After installation of Safe Torque Off (STO), a commissioning test must be performed. A passed commissioning test is mandatory after first installation and after each change to the safety installation.

#### Safe Torque Off Technical Data

The following values are associated to the different types of safety levels:

##### Reaction time for T37

- Maximum reaction time: 10 ms

Reaction time = delay between de-energizing the STO input and switching off the frequency converter output bridge.

##### Data for EN ISO 13849-1

- Performance Level "d"
- MTTFD (Mean Time To Dangerous Failure): 24816 years
- DC (Diagnostic Coverage): 99%
- Category 3
- Lifetime 20 years



**Data for EN IEC 62061, EN IEC 61508, EN IEC 61800-5-2**

- SIL 2 Capability, SILCL 2
- PFH (Probability of Dangerous failure per Hour)= $7e-10$ FIT= $7e-19$ /h
- SFF (Safe Failure Fraction) >99%
- HFT (Hardware Fault Tolerance)=0 (1001 architecture)
- Lifetime 20 years

**Data for EN IEC 61508 low demand**

- PFD<sub>avg</sub> for one-year proof test: 3, 07E-14
- PFD<sub>avg</sub> for three year proof tests: 9, 20E-14
- PFD<sub>avg</sub> for five year proof tests: 1, 53E-13

No maintenance of the STO functionality is needed.

Take the necessary security measures, e.g. installation in a closed cabinet that is only accessible for skilled personnel.

**SISTEMA Data**

Functional safety data is available via a data library for use with the SISTEMA calculation tool from the IFA (Institute for Occupational Safety and Health of the German Social Accident Insurance), and data for manual calculation. The library is permanently completed and extended.

Abbrev.	Ref.	Description
Cat.	EN 954-1	Category, level "B, 1-4"
FIT		Failure In Time: 1E-9 hours
HFT	IEC 61508	Hardware Fault Tolerance: HFT = n means, that n+1 faults could cause a loss of the safety function
MTTFd	EN ISO 13849-1	Mean Time To Failure - dangerous. Unit: years
PFH	IEC 61508	Probability of Dangerous Failures per Hour. Consider the PFH value when the safety device is operated in high demand (more often than once per year); or operated in continuous mode, where the frequency of demands for operation made on a safety-related system is greater than one per year.
PL	EN ISO 13849-1	Discrete level used to specify the ability of safety-related parts of control systems to perform a safety function under foreseeable conditions. Levels a-e.
SFF	IEC 61508	Safe Failure Fraction [%]; Percentage part of safe failures and dangerous detected failures of a safety function or a subsystem related to all failures.
SIL	IEC 61508	Safety Integrity Level
STO	EN 61800-5-2	Safe Torque Off
SS1	EN 61800-5-2	Safe Torque Off 1

**Table 2.1 Abbreviations Related to Functional Safety**

The PFD<sub>avg</sub> value (Probability of Failure on Demand) Failure probability in the event of a request of the safety function.

**2.2.1 Terminal 37 Safe Torque Off Function**

The frequency converter is available with Safe Torque Off functionality via control terminal 37. Safe Torque Off disables the control voltage of the power semiconductors of the frequency converter output stage. This in turn prevents generating the voltage required to rotate the motor. When the Safe Torque Off (T37) is activated, the frequency converter issues an alarm, trips the unit, and coasts the motor to a stop. Manual restart is required. The Safe Torque Off function can be used as an emergency stop for the frequency converter. In normal operating mode when Safe Torque Off is not required, use the regular stop function instead. When automatic restart is used, ensure the requirements of ISO 12100-2 paragraph 5.3.2.5 are fulfilled.

**Liability Conditions**

Ensure that qualified personnel installs and operates the Safe Torque Off function:

## Safety Instructions and Gen...

- Read and understand the safety regulations concerning health and safety/accident prevention
- Understand the generic and safety guidelines given in this description and the extended description in the relevant *Design Guide*
- Have a good knowledge of the generic and safety standards applicable to the specific application

User is defined as:

- integrator
- operator
- service technician
- maintenance technician

### Standards

Use of Safe Torque Off on terminal 37 requires fulfilling of all provisions for safety, including relevant laws, regulations and guidelines. The optional Safe Torque Off function complies with the following standards.

- IEC 60204-1: 2005 category 0 – uncontrolled stop
- IEC 61508: 1998 SIL2

## **⚠ WARNING**

### **SAFE TORQUE OFF FUNCTION!**

The Safe Torque Off function does NOT isolate mains voltage to the frequency converter or auxiliary circuits. Perform work on electrical parts of the frequency converter or the motor only after isolating the mains voltage supply and waiting the length of time specified in *chapter 2.1.6 General Warning*. Failure to isolate the mains voltage supply from the unit and waiting the time specified could result in death or serious injury.

- It is not recommended to stop the frequency converter by using the Safe Torque Off function. If a running frequency converter is stopped by using the function, the unit trips and stops by coasting. If unacceptable or dangerous, use another stop mode to stop the frequency converter and machinery, before using this function. Depending on the application, a mechanical brake can be required.

3

### 3 How to Install

#### 3.1 Environment

##### 3.1.1 Ambient Temperature and Altitude

The normal ambient temperature range supported by the frequency converter is -10 °C to +50 °C without derating. The operates normally down to -20 °C with only the keypad display function impaired but without performance reduction.

For ambient temperatures above +50 °C, it is mandatory to integrate the derating output factor for the maximum compressor electrical motor power/current.

For altitudes above 1000 m, apply derating as shown in Table 3.1.

For more details on derating due to environmental factors, contact Trane technical support.

Altitude [m]	Derating factor
1,000	1
1,500	0.95
2,000	0.90
2,500	0.86
3,000	0.82
3,500	0.78

Table 3.1 Altitude Derating Factor

##### 3.1.2 Environmental Requirements for Mechanical Installation

The unit is air-cooled. To protect the unit from overheating, ensure that the ambient temperature does not exceed the maximum temperature stated for the 24-hour average temperature. If the ambient temperature is in the range of 45 °C to 55 °C, derating becomes relevant. If derating for ambient temperature is not taken into account, the service life of the unit is reduced.

#### 3.2 Mechanical Installation

##### 3.2.1 Accessory Bags

Find the following parts included in the accessory bag:

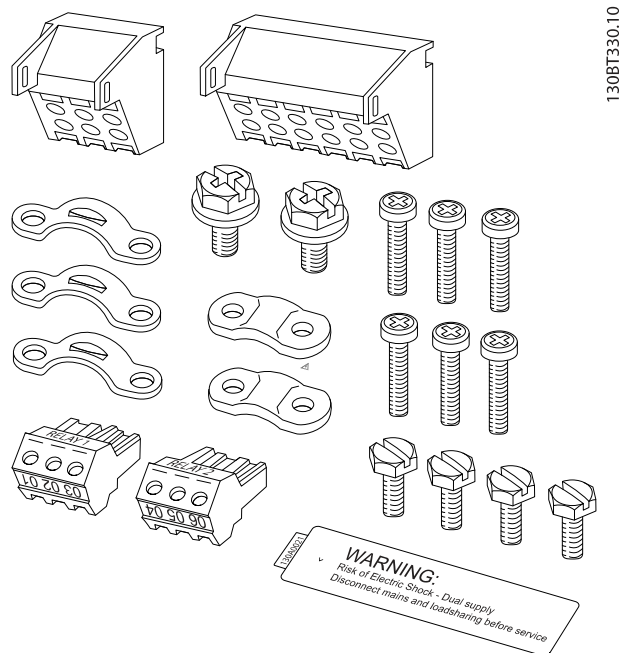

130BT330.10

Illustration 3.1 Enclosures B1 and B2, IP21/IP55/Type 1/Type 12

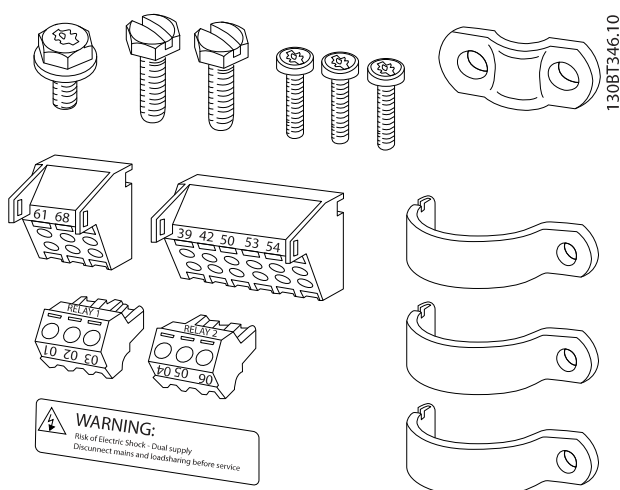

130BT346.10

Illustration 3.2 Enclosure B3, IP20/Chassis

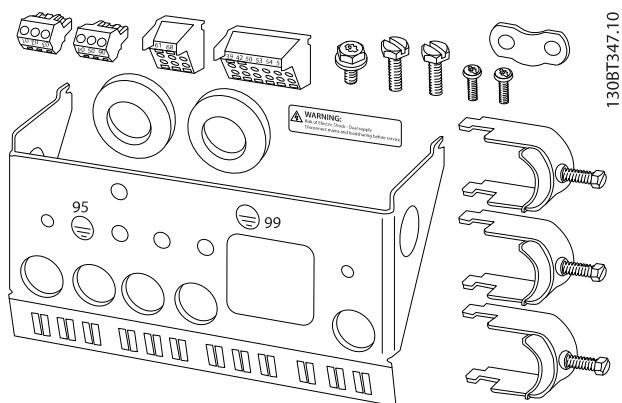

Illustration 3.3 Enclosure B4, IP20/Chassis

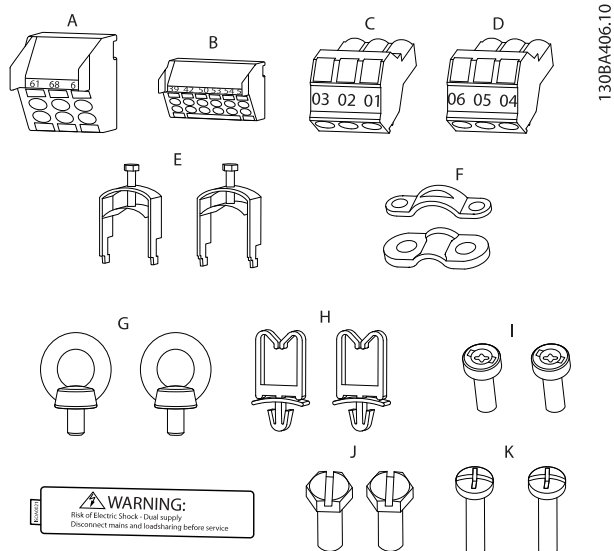

Illustration 3.4 Enclosures C1 and C2, IP55/66/Type 1/Type 12

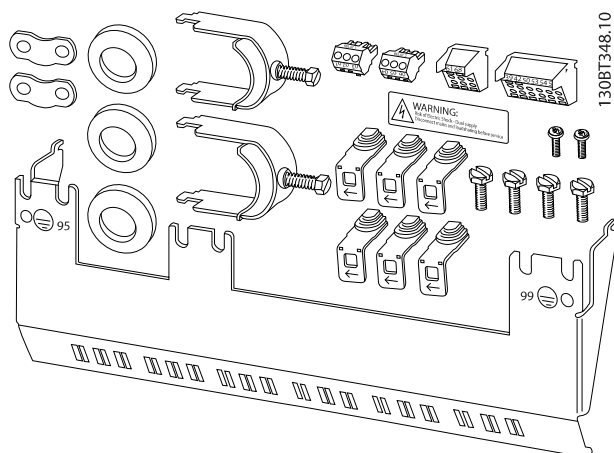

Illustration 3.5 Enclosure C3, IP20/Chassis

### 3.2.2 Mechanical Mounting

1. Drill holes in accordance with the measurements given.
2. Provide screws suitable for the surface on which the compressor drive should be mounted.
3. Retighten all four screws.

The frequency converter IP20 allows side-by-side installation. Because of the need for cooling, there must be a minimum of 200 mm free air passage above and below the frequency converter.

The back wall must always be solid. All frequency converters are equipped with a back metal plate to guarantee proper heat exchanger ventilation. Never remove this metal sheet.

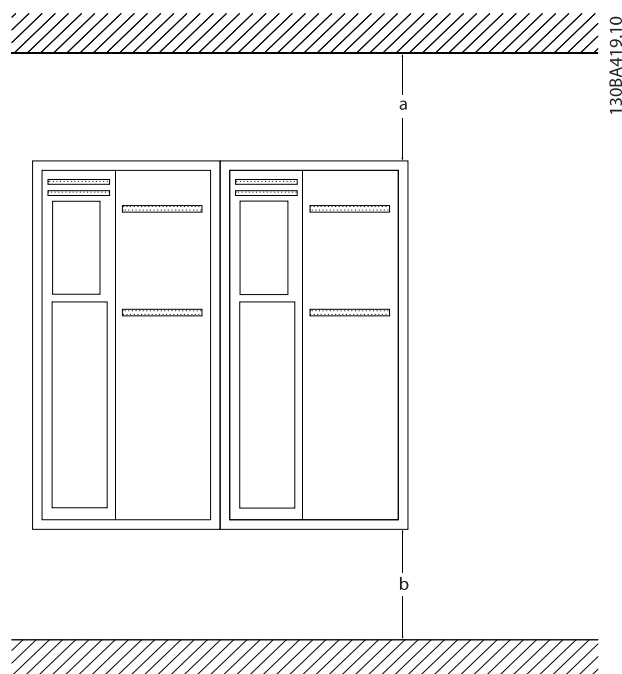

Illustration 3.6 Clearance

Frame size	A1*/A2/A3/A4/A5/B1	B2/B3/B4/C1/C3	C2/C4
a [mm]	100	200	225
b [mm]	100	200	225

Table 3.2 Air Passage for Different Frame Sizes

### 3.2.3 Mechanical Dimensions

IP 20 Chassis	T2 [240 V]	T4 [480 V]	T6 [575 V]
VZH088 [18 kW]	B4	B3	B3
VZH117 [22 kW]	C3	B4	B4
VZH170 [30 kW]	C3	B4	B4

Table 3.3 Related VZH Numbers

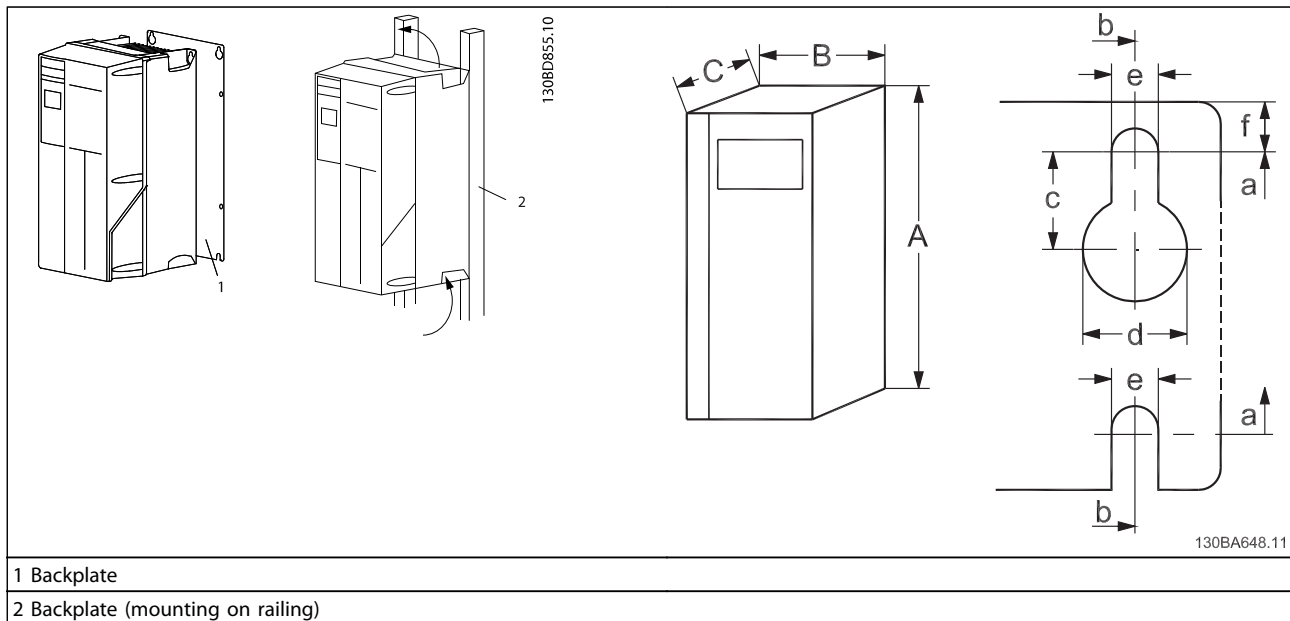

1 Backplate

2 Backplate (mounting on railing)

Table 3.4 Dimensional Drawings

		B1	B2	B3	B4	C1	C3
<b>Height [mm]</b>							
Backplate	A	480	650	399	520	680	550
Distance between mounting holes	a	454	624	380	495	648	521
<b>Width [mm]</b>							
Back plate	B	242	242	165	230	308	308
Distance between mounting holes	b	210	210	140	200	272	270
<b>Depth [mm]</b>							
Without option	C	260	260	249	242	310	333
With option	C	260	260	262	242	310	333
<b>Screw holes [mm]</b>							
	c	12.0	12.0	8		12.0	
	d	Ø 19.0	Ø 19.0	12		Ø 19.0	
	e	Ø 9.0	Ø 9.0	8.8	8.5	Ø 9.0	8.5
	f	9.0	9.0	7.9	15	9.8	17
<b>Other specifications</b>							
Max. weight [kg]		23.0	27.0	12	23.5	45	50

Table 3.5 Mechanical Dimensions

### 3.3 Electrical Installation

#### 3.3.1 Cables General

## **CAUTION**

Cables general:

Always comply with national and local regulations on cable cross-sections.

Frame size	200-240 V [kW]	380-500 V [kW]	525-690 V [kW]	Cable for	Tightening torque [Nm]
B3	5.5-7.5	11-15	15	Mains, motor cables	1.8
				Relay	0.5-0.6
				Earth	2-3
B4	11-15	18.5-30	18.5-22	Mains, motor cables	4.5
				Relay	0.5-0.6
				Earth	2-3
C3	18.5-22	-	-	Mains, motor cables	10
				Relay	0.5-0.6
				Earth	2-3

Table 3.6 Tightening Torque

#### 3.3.2 Removal of Knockouts for Extra Cables

- Remove cable entry from the frequency converter (avoiding foreign parts in the frequency converter when removing knockouts)
- Support cable entry around the knockout that should be removed
- The knockout can now be removed with a strong mandrel and a hammer
- Remove burrs from the hole
- Mount cable entry on frequency converter

#### 3.3.3 Mains Connection for B1, B2 and B3

### **NOTICE**

Frequency converter sizes differ, but terminal numbers are always the same. Incoming power is always 91, 92, 93 labeled L1, L2, L3.

NOTE: For correct cable dimensions, see *chapter 8 General Specifications*.

3

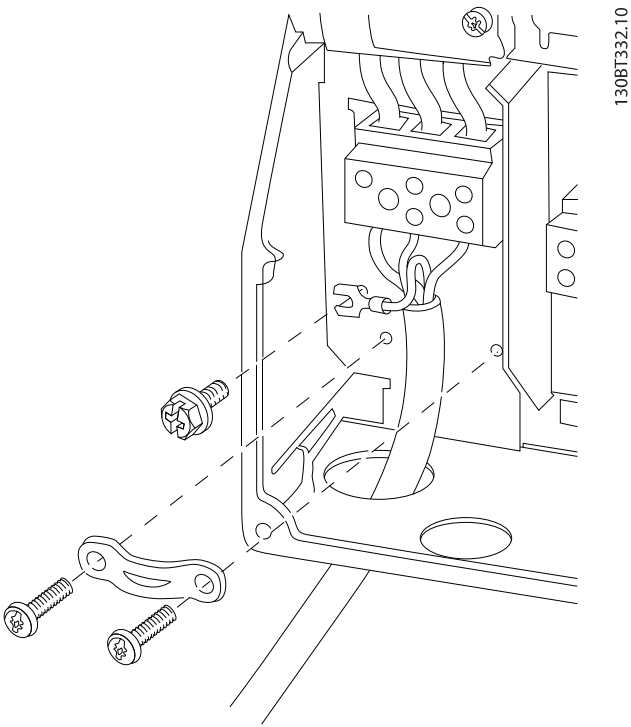

Illustration 3.7 How to Connect to Mains and Earthing for B1 and B2

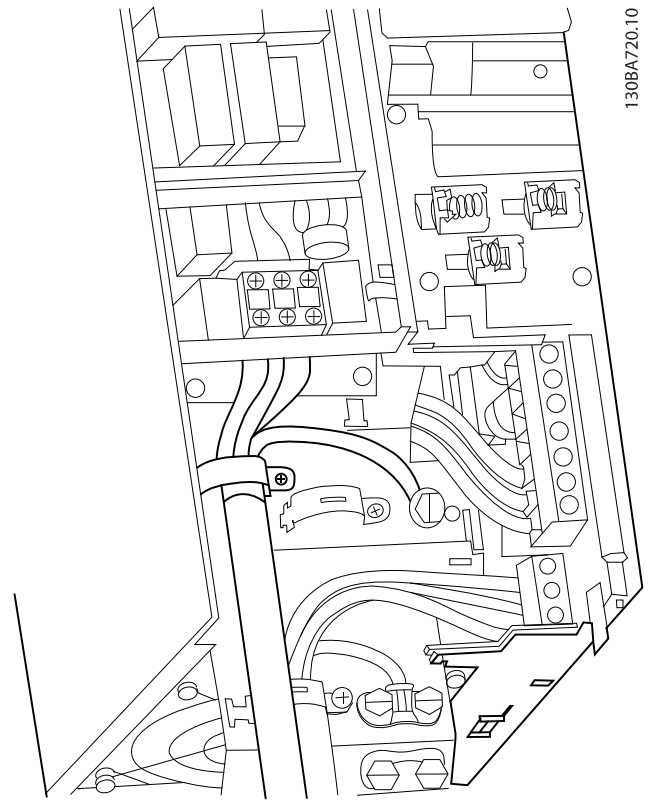

Illustration 3.9 How to Connect to Mains and Earthing for B3 with RFI

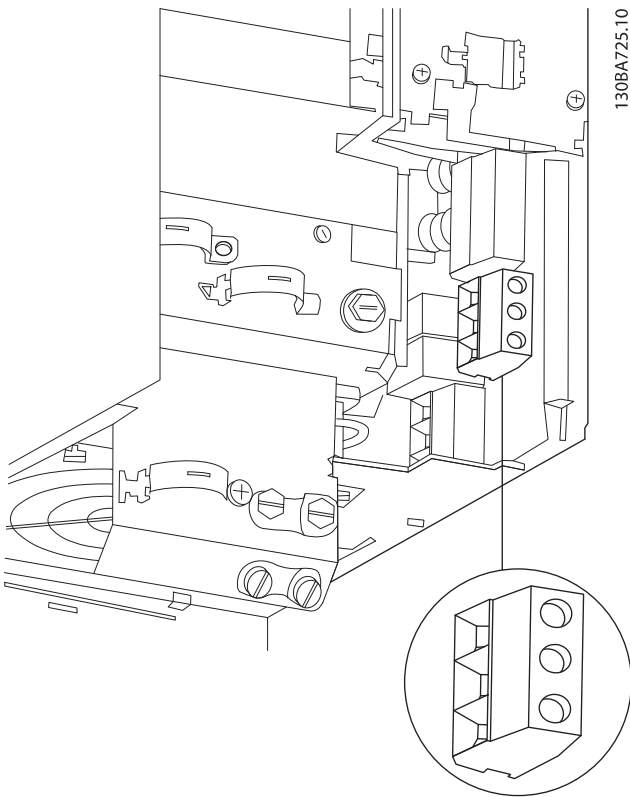

Illustration 3.8 How to Connect to Mains and Earthing for B3 without RFI

### 3.3.4 Mains connection for B4, C1 and C3

**NOTICE**

Frequency converter sizes differ but terminal numbers are always the same. Incoming power is always 91, 92, 93 labeled L1, L2, L3.

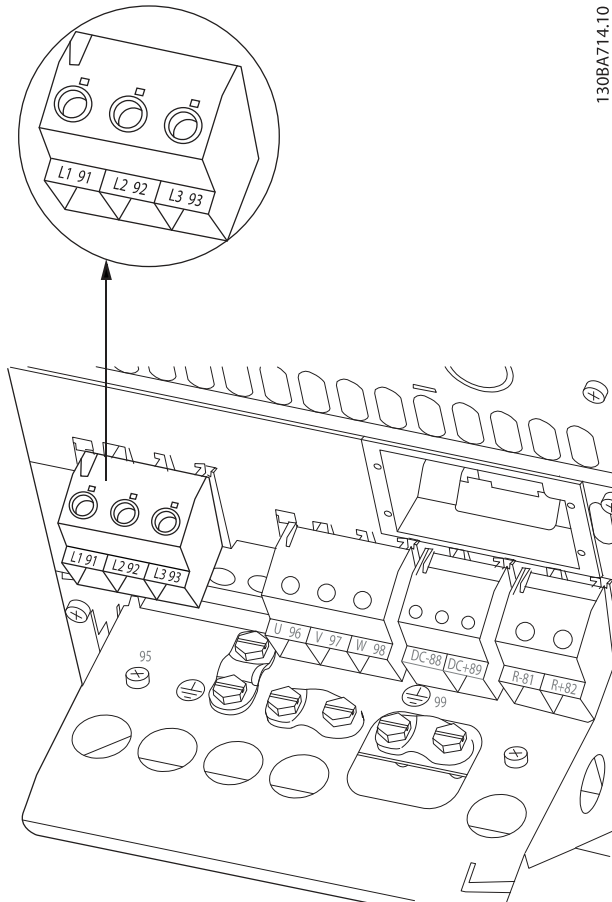

Illustration 3.10 How to Connect to Mains and Earthing for B4

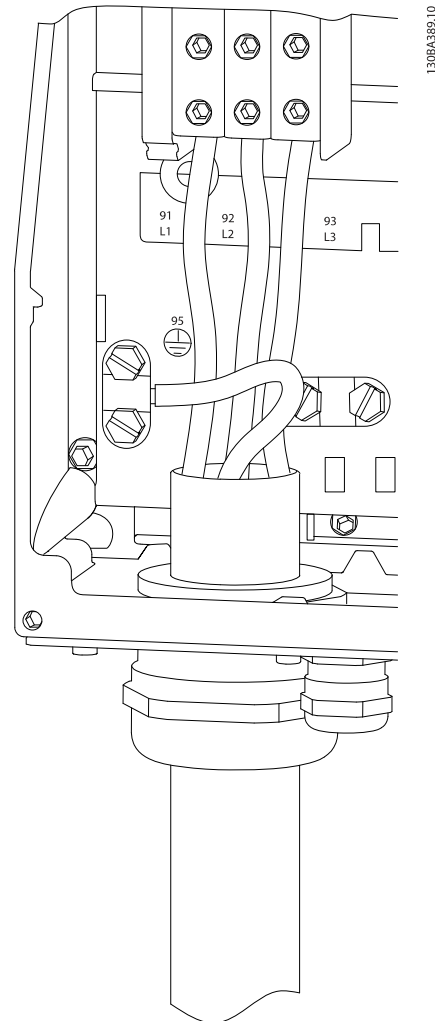
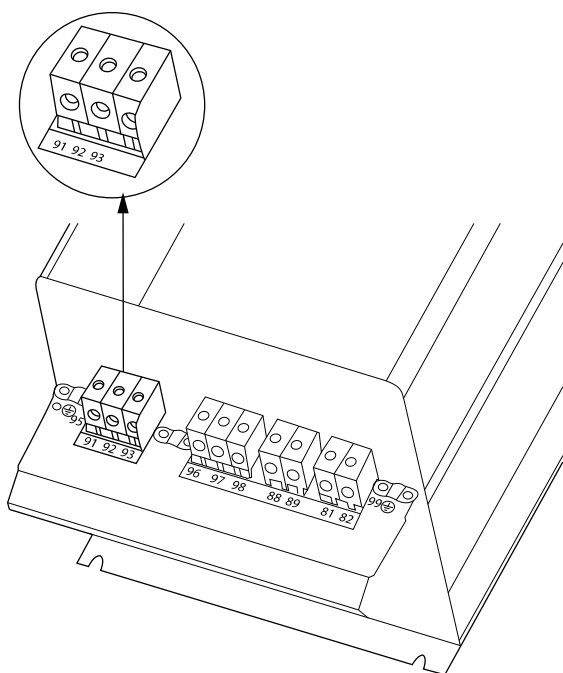

Illustration 3.11 How to Connect to Mains and Earthing for C1 and C2



3



130BA718.10

Illustration 3.12 How to Connect C3 to Mains and Earthing

### 3.3.5 Motor Compressor Connection

**NOTICE**

Always wire terminal 96 (U) to T1, 97 (V) to T2, and 98 (W) to T3.

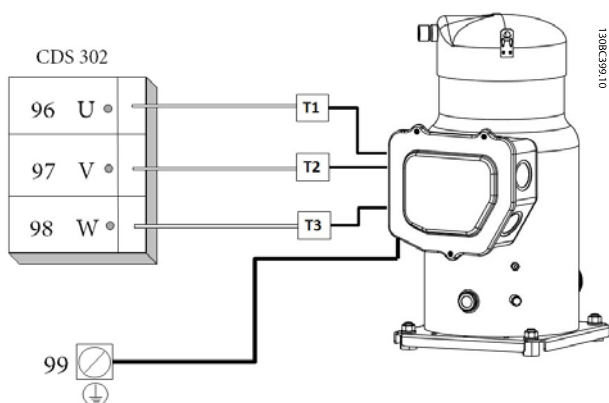

01166E90E1

Illustration 3.13 Motor/Compressor Wiring

Motor compressor cable must be screened/armoured. If an unscreened/unarmoured cable is used, some EMC requirements are out of compliance. For more information, see EMC specifications.

1. Fasten decoupling plate to the bottom of the frequency converter with screws and washers from the accessory bag.
2. Attach motor compressor cable to terminals 96 (U), 97 (V), 98 (W).
3. Connect to earth connection (terminal 99) on decoupling plate with screws from the accessory bag.
4. Insert terminals 96 (U), 97 (V), 98 (W) and motor compressor cable to terminals labelled MOTOR.
5. Fasten screened cable to decoupling plate with screws and washers from the accessory bag.
6. Connect U, V, W for motor compressor clockwise.

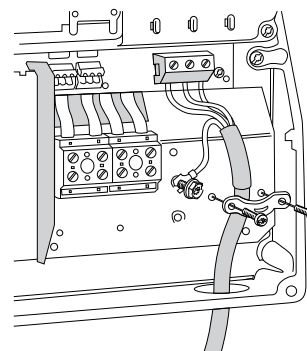

130BT133.10

Illustration 3.14 How to Connect to Motor Terminals B1/B2

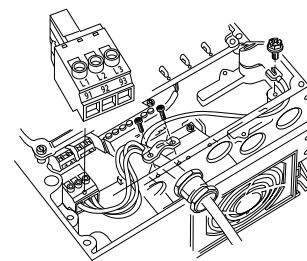

130BT346.10

Illustration 3.15 How to Connect to Mains and Earth without Mains Disconnect

### 3.3.6 Motor Compressors Cables

Correct dimensioning of motor compressor cable cross-section and length is described in the application manual.

- Use a screened/armoured motor compressor cable to comply with EMC emission specifications
- Keep the motor compressor cable as short as possible to reduce the noise level and leakage currents
- Connect the motor compressor cable screen to both the decoupling plate of the frequency

converters and to the metal cabinet of the motor compressor

- Make the screen connections with the largest possible surface area (cable clamp). Use the supplied installation devices in the frequency converter for making the screen connections.

### 3.3.7 Electrical Installation of Motor Compressor Cables

#### Screening of cables

Avoid installation with twisted screen ends (pigtails). They reduce the screening effect at higher frequencies.

#### Cable length and cross section

The frequency converter has been tested with a given length of cable and a given cross section of that cable. If the cross section is increased, the cable capacitance - and thus the leakage current - may increase, and the cable length must be reduced correspondingly.

#### Aluminium conductors

Aluminium conductors are not recommended. Terminals accept aluminium conductors, but clean the conductor surface and remove and seal the oxidation by neutral acid-free Vaseline grease before the conductor is connected. Furthermore, the terminal screw must be retightened after two days due to the softness of the aluminium. It is crucial to keep the connection a gas tight joint, otherwise the aluminium surface oxidises again.

### 3.3.8 Compressor Motor Protection

The frequency converter fully provides electrical compressor motor protection.

- The frequency converter makes through an electronic current measurement anti-overload and lock-rotor compressor motor protection (see description in the application manual).
- The frequency converter is protected against short circuits on compressor terminals T1, T2, T3
- If a mains phase is missing, the frequency converter trips or issues a warning (depending on the load)
- If a compressor motor phase is missing, the frequency converter trips
- The frequency converter is protected against earth faults on compressor motor terminals T1, T2, T3

### 3.3.9 Access to Control Terminals

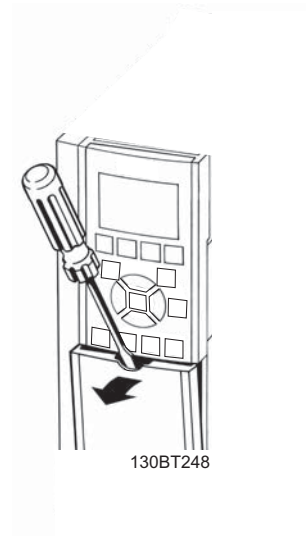

Illustration 3.16 B3, B4 and C3 Enclosures

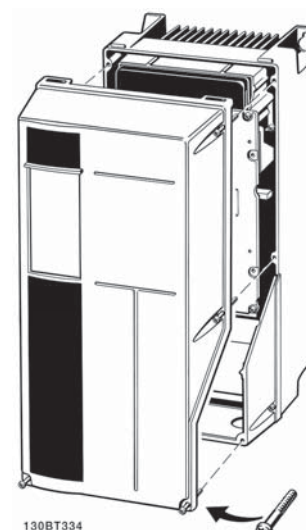

Illustration 3.17 C1, B1 and B2 Enclosures

Control terminals are located beneath the keypad. The inside of the removable cover shows the terminals.

3

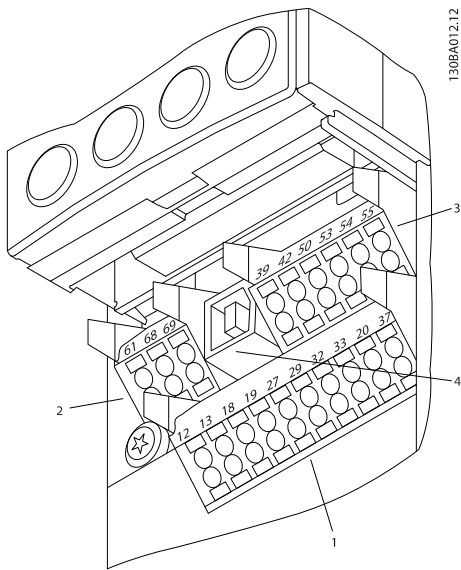

Illustration 3.18 Control Terminals

1. 10 pole plug digital I/O
2. 3 pole plug RS-485 Bus
3. 6 pole analog I/O
4. USB Connection

To mount the cable to the terminal:

1. Strip isolation of 9-10 mm.
2. Insert a screwdriver in the square hole.
3. Insert the cable in the adjacent circular hole.
4. Remove the screwdriver. The cable is now mounted to the terminal.

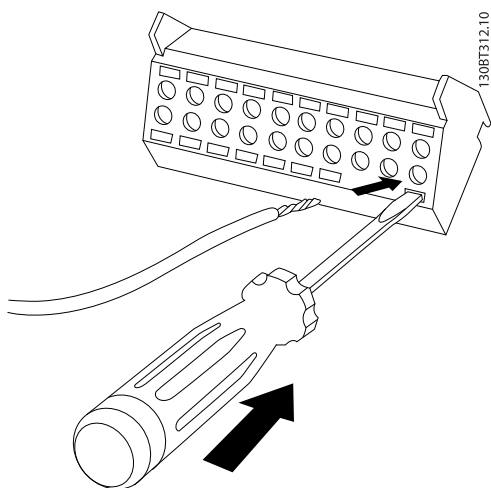

Illustration 3.19 Mounting the Cable

To remove the cable from the terminal:

1. Insert a screwdriver in the square hole.
2. Pull out the cable.

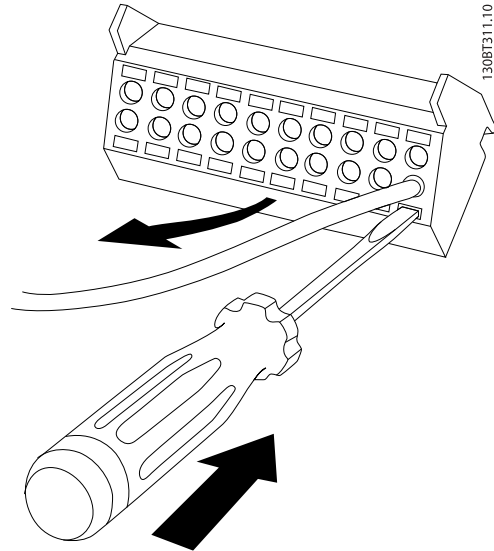

Illustration 3.20 Removing the Cable

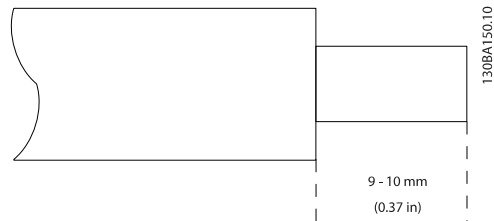

Illustration 3.21 Stripping the Cable

### 3.3.10 Basic Wiring Example

1. Mount terminals from the accessory bag to the front of the frequency converter.

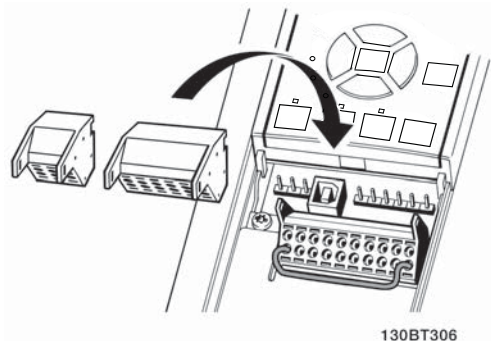

Illustration 3.22 Mounting the Terminals

2. Connect terminals 18, 27 and 37 to +24 V (terminal 12/13)

Default settings:

18 = start

27 = coast inverse

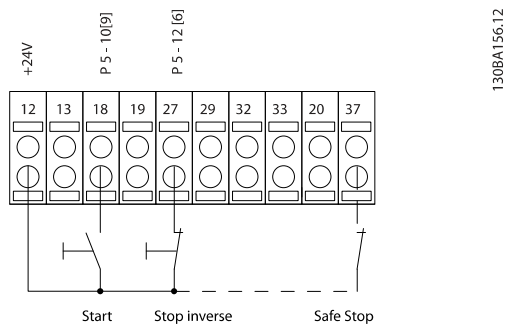

130BA156.12

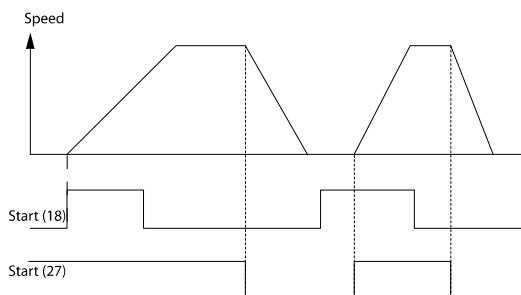

Illustration 3.23 Example of Basic Wiring & System Response

### 3.3.11 Electrical Installation, Control Cables

Use terminal 37 as input for safe stop. In rare cases, control cables more than 100 m (330 ft) and analog signals result in 50/60 Hz earth loops due to noise from mains supply cables. If this situation occurs, break the screen or insert a 100 nF capacitor between screen and chassis. Connect the digital and analog inputs and outputs separately to the frequency converter common inputs (terminal 20, 55, 39) to avoid earth currents affecting the system.

3

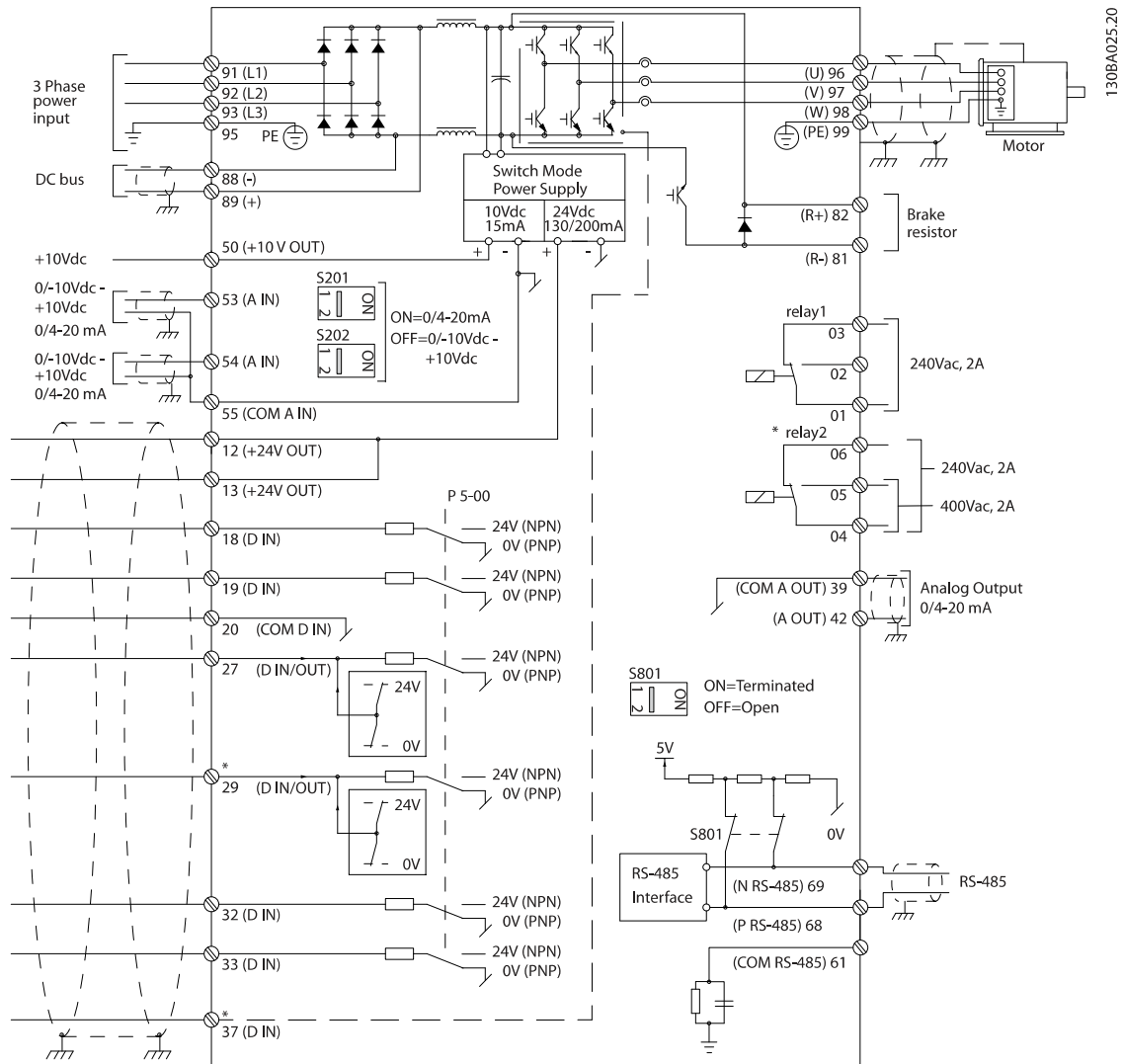

Illustration 3.24 Electrical Diagram - Control Cables

## How to Install

Control cables must be screened/armoured. To connect the screen to the frequency converter decoupling plate for control cables, use a clamp from the accessory bag.

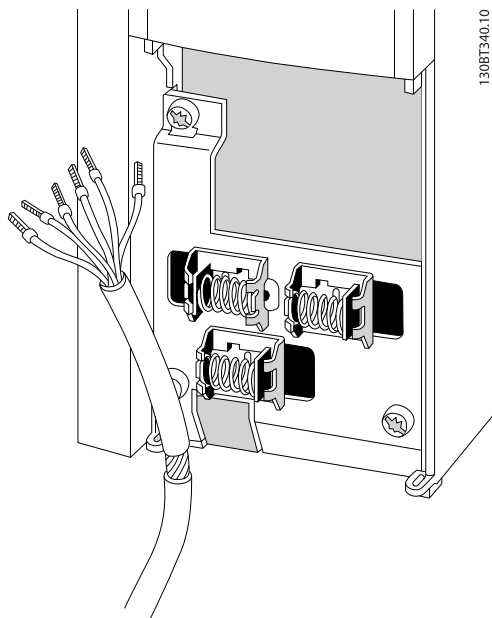

Illustration 3.25 Control Cable Connection

Illustration 3.26 indicates how correct earthing is carried out and what to do if in doubt.

### a. Correct earthing

Control cables and cables for serial communication must be fitted with cable clamps at both ends to ensure the best possible electrical contact.

### b. Wrong earthing

Do not use twisted cable ends (pigtails). They increase the screen impedance at high frequencies.

### c. Protection concerning earth potential between PLC (Program Logic Controller) and frequency converter

If the earth potential between the frequency converter and the PLC (etc.) is different, electric noise may occur that disturbs the entire system. Solve this problem by fitting an equalising cable, next to the control cable. Minimum cable cross-section: 16 mm<sup>2</sup>.

### d. For 50/60 Hz earth loops

If long control cables are used, 50/60 Hz earth loops may occur. Solve this problem by connecting one end of the screen to earth via a 100 nF capacitor (keeping leads short).

### e. Cables for serial communication

Eliminate low-frequency noise currents between two frequency converters by connecting one end of the screen

to terminal 61. This terminal is connected to earth via an internal RC link. To reduce the differential mode interference between the conductors, use twisted-pair cables.

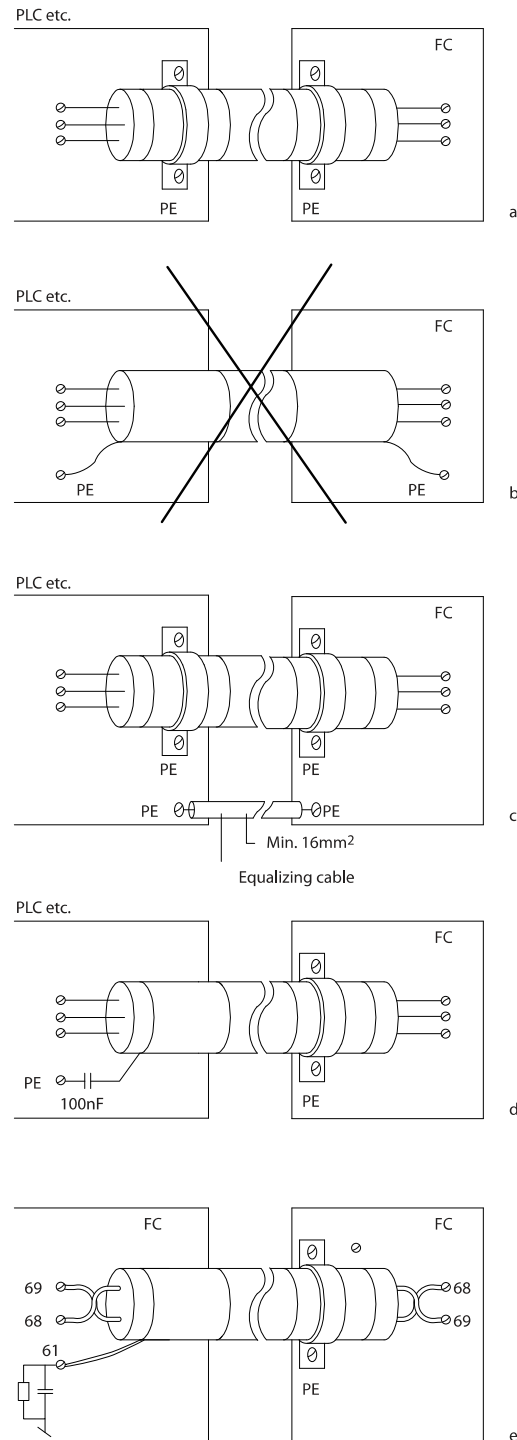

Illustration 3.26 Examples of Earth Wiring

### 3.3.12 Electrical Installation - EMC Protection

The following is a guideline to good engineering practice when installing frequency converters. To comply with EN 61800-3 First environment, follow these guidelines. If the installation is in EN 61800-3 Second environment, i.e. industrial networks, or in an installation with its own transformer, deviation from these guidelines is allowed, but not recommended.

#### Good engineering practice to ensure EMC-correct electrical installation

- Use only braided screened/armoured motor compressor cables and braided screened/armoured control cables. The screen should provide a minimum coverage of 80%. The screen material must be metal, not limited to but typically copper, aluminium, steel, or lead. There are no special requirements for the mains cable.
- Installations using rigid metal conduits are not required to use screened cable, but the motor compressor cable must be installed in conduit separate from the control and mains cables. Full connection of the conduit from the frequency converter to the motor compressor is required. The EMC performance of flexible conduits varies a lot and information from the manufacturer must be obtained.
- Connect the screen/armour/conduit to earth at both ends for motor compressor cables as well as for control cables. In some cases, it is not possible to connect the screen in both ends. If so, connect the screen at the frequency converter. See also *chapter 3.3.11 Electrical Installation, Control Cables*.
- Avoid terminating the screen/armour with twisted ends (pigtailed). It increases the high frequency impedance of the screen, which reduces its effectiveness at high frequencies. Use low impedance cable clamps or EMC cable glands instead.
- Avoid using unscreened/unarmoured motor compressor or control cables inside cabinets housing the frequency converter(s).

Leave the screen as close to the connectors as possible.

*Illustration 3.27* shows an example of an EMC-correct electrical installation of an IP20 frequency converter. The frequency converter is fitted in an installation cabinet with an output contactor and connected to a PLC, which is installed in a separate cabinet. Other ways of doing the installation may have just as good an EMC performance, provided the above guide lines to engineering practice are followed. Installing without following the guideline, and using unscreened cables and control wires do not comply with all emission requirements, although the immunity requirements are fulfilled.

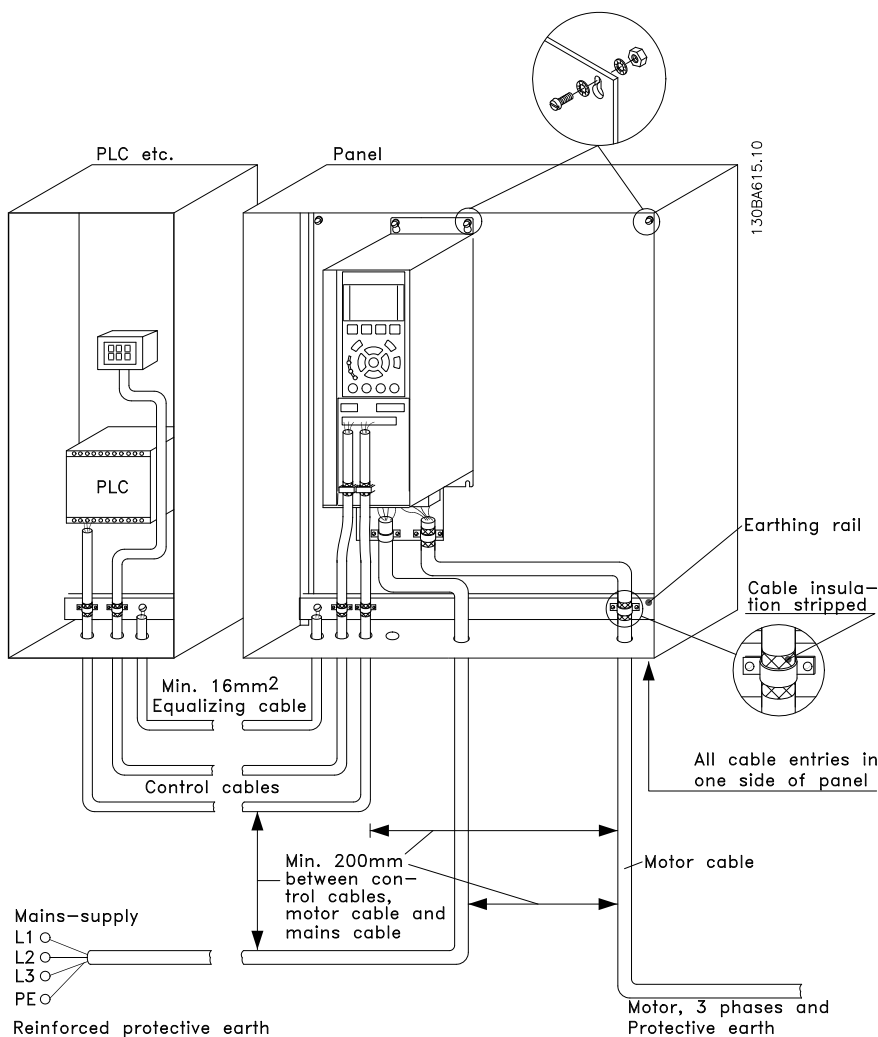

Illustration 3.27 EMC Correct Installation of an IP20 Frequency Converter

### 3.3.13 Motor Thermal Protection

The electronic thermal relay in the frequency converter has received UL-approval for single motor protection, when *1-90 Motor Thermal Protection* is set for [4] *ETR Trip 1* and *1-24 Motor Current* is set to the rated motor current (see motor name plate).

For thermal motor protection, it is also possible to use the VLT® PTC Thermistor Card MCB 112. This card provides ATEX certification to protect motors in explosion hazardous areas, Zone 1/21 and Zone 2/22. When *1-90 Motor Thermal Protection* is set to [20] *ATEX ETR* and MCB 112 are combined, it is possible to control an Ex-e motor in explosion hazardous areas. Consult the *Programming Guide* for details on how to set up the frequency converter for safe operation of Ex-e motors.

### 3.3.14 Safety Earth Connection

The frequency converter has a high leakage current and must be earthed appropriately for safety reasons according to EN 50178. The earth leakage current from the frequency converter exceeds 3.5 mA. To ensure a good mechanical connection from the earth cable to the earth connection (terminal 95), the cable cross-section must be at least 10 mm<sup>2</sup> or 2 rated earth wires terminated separately.



### 3.3.15 Basic Examples of Control Connections

Controls using an external controller with 0-10 V signal. It is not necessary to change any parameters, as this is the default value.

3

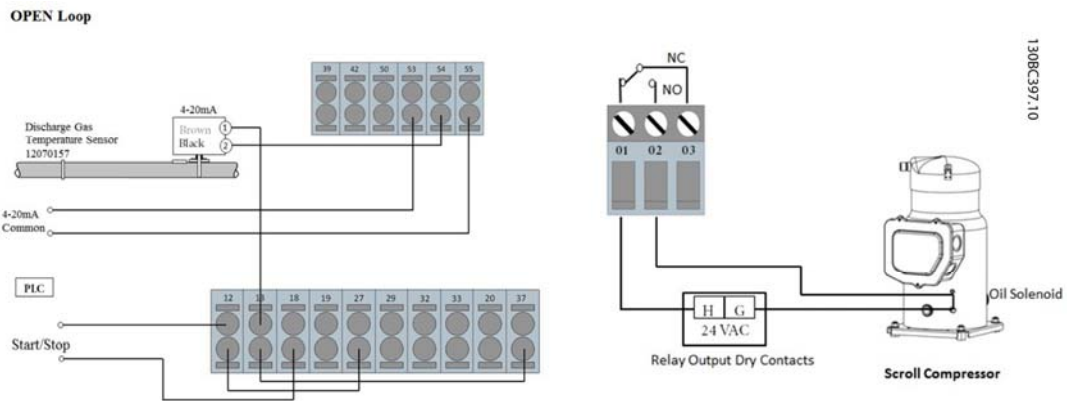

Illustration 3.28 Example of External Controller with 0-10 V Signal

Controls using an external controller with 4-20 mA signal. Change switch 53 from U to I. It is not necessary to change any parameters, as this is the default value.

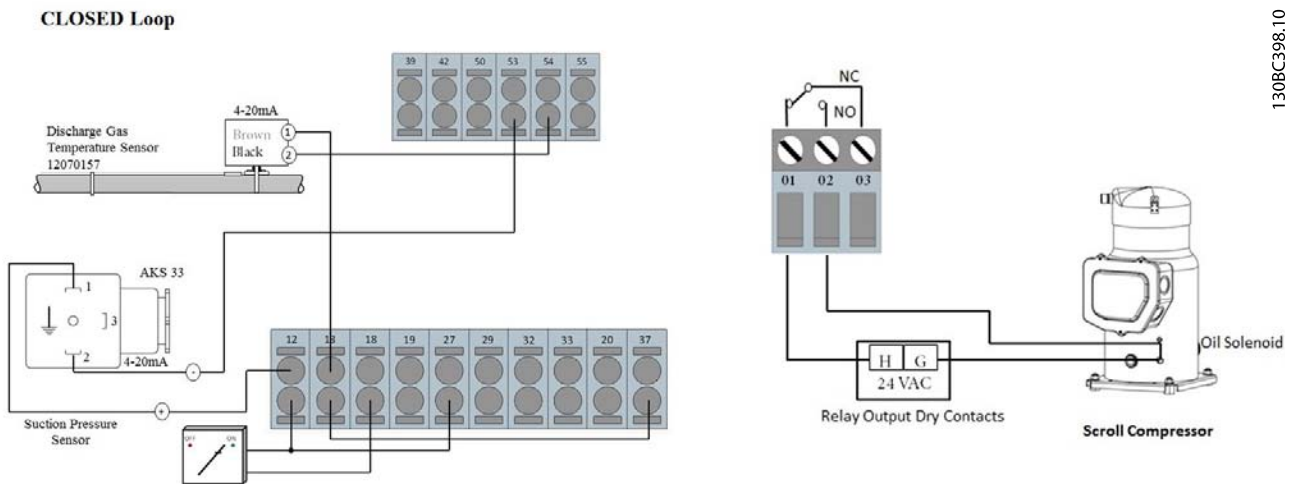

Illustration 3.29 Example of External Controller with 4-20 mA Signal

### 3.3.16 High-voltage Test

Carry out a high-voltage test by short-circuiting terminals U, V, W, L1, L2 and L3. Energise by max. 2.15 kV DC for 1 s between this short circuit and the chassis.

#### **NOTICE**

When running high-voltage tests of the entire installation, frequency converter and compressor electrical motor compressor test can be conducted together.

#### **⚠ WARNING**

When conducting a high-voltage test, make sure that the system is not under vacuum: a vacuum may cause electrical motor compressor failure.

#### **⚠ WARNING**

Never apply the high-voltage test to the control circuit.

## 3.4 Fuses and Circuit Breakers

### 3.4.1 Fuses

#### **NOTICE**

To ensure compliance with IEC 60364 for CE or NEC 2009 for UL, use fuses and/or circuit breakers on the supply side of the unit for protection of electrical components within the frequency converter.

#### **⚠ WARNING**

Personnel and property must be protected against the consequence of component break-down internally in the frequency converter.

#### **Branch circuit protection**

To protect the installation against electrical and fire hazard, all branch circuits in an installation, switch gear, machines etc., must be protected against short circuit and over-current according to national/international regulations.

#### **Short circuit protection**

Trane recommends using the fuses/circuit breakers listed in the following tables to protect service personnel and property in case of component break-down in the frequency converter.

### 3.4.2 Recommendations

#### **⚠ WARNING**

In case of malfunction, ignoring recommended fuse types may result in personnel risk and damage to the frequency converter and other equipment.

The following tables list the recommended rated current. Recommended fuses are of the type gG for small to medium power sizes. For larger powers, aR fuses are recommended. For circuit breakers, Moeller types have been tested to have a recommendation. Other circuit breakers may be used if they limit the energy into the frequency converter to a level equal to or lower than the Moeller types.

For further information, see Application Note *Fuses and Circuit Breakers, MN90T*

### 3.4.3 CE Compliance

Fuses or circuit breakers are mandatory to comply with IEC 60364. Trane recommends using a selection of the following.

The fuses below are suitable for use on a circuit capable of delivering 100,000 Arms (symmetrical), 240 V, 480 V, 500 V, or 600 V depending on the unit's voltage rating. With the proper fusing, the frequency converter short circuit current rating (SCCR) is 100,000 Arms.

### 3.4.4 Non UL Compliance Fuses

#### Non-UL compliance fuses

Compressor model	Frequency converter	Voltage [V]	Output power [kW/HP]	Max. fuse size [A]	Type
VZH088	15K	200-240	18.5/25	80 <sup>1</sup>	type gG
VZH117	18K5	200-240	22/30	125 <sup>1</sup>	type gG
VZH170	22K	200-240	30/40	125 <sup>1</sup>	type gG
VZH088	15K	380-480	18.5/25	63 <sup>1</sup>	type gG
VZH117	18K	380-480	22/30	63 <sup>1</sup>	type gG
VZH170	22K	380-480	30/40	80 <sup>1</sup>	type gG

**Table 3.7 Non-UL Fuses 200 V to 480 V**

1) Max. fuses - see national/international regulations for selecting an applicable fuse size.

#### UL compliance fuses

Compressor model	Frequency converter [kW]	Output power [kW/HP]	Bussmann Type RK1	Bussmann Type J	Bussmann Type T	SIBA Type RK1	Littelfuse Type RK1	Ferraz-Shawmut Type CC	Ferraz-Shawmut Type RK1
VZH088	15K	18.5/25	KTN-R125	JKS-125	JJN-125	5014006-125	KLN-R125	A2K-125R	A2K-125R
VZH117	18K5	22/30	KTN-R125	JKS-125	JJN-125	2028220-125	KLN-R125	A2K-125R	A2K-125R
VZH170	22K	30/40	KTN-R150	JKS-150	JJN-150	2028220-150	KLN-R150	A2K-150R	A2K-150R

**Table 3.8 UL Fuses, 200-240 V**

Compressor model	Frequency converter [kW]	Output power [kW/HP]	Bussmann Type RK1	Bussmann Type J	Bussmann Type T	SIBA Type RK1	Littelfuse Type RK1	Ferraz-Shawmut Type CC	Ferraz-Shawmut Type RK1
VZH088	15K	18.5/25	KTS-R60	JKS-60	JJS-60	5014006-040	KLS-R60	-	A6K-60R
VZH117	18K	22/30	KTS-R60	JKS-60	JJS-60	5014006-050	KLS-R60	-	A6K-60R
VZH170	22K	30/40	KTS-R80	JKS-80	JJS-80	5014006-063	KLS-R80	-	A6K-80R

**Table 3.9 UL Fuses, 380-600 V**

## How to Install

Compressor model	Frequency converter [kW]	Output power [kW/HP]	Bussmann Type RK1	Bussmann Type J	Bussmann Type T	SIBA Type RK1	Littelfuse Type RK1	Ferraz-Shawmut Type CC	Ferraz-Shawmut Type RK1
VZH088	18K	18.5/25	KTS-R45	JKS-45	JJS-45	5014006-040	KLS-R45	-	A6K-45R
VZH117	22K	22/30	KTS-R50	JKS-50	JJS-50	5014006-050	KLS-R50	-	A6K-50R
VZH170	30K	37.5/50	KTS-R80	JKS-80	JJS-80	2028220-100	KLS-R80	-	A6K-80R

3

**Table 3.10 UL Fuses, 525-600 V**

KTS-fuses from Bussmann may substitute KTN for 240 V frequency converters.

FWH-fuses from Bussmann may substitute FWX for 240 V frequency converters.

KLSR fuses from LITTELFUSE may substitute KLNR fuses for 240 V frequency converters.

L50S fuses from LITTELFUSE may substitute L50S fuses for 240 V frequency converters.

A6KR fuses from FERRAZ SHAWMUT may substitute A2KR for 240 V frequency converters.

A50X fuses from FERRAZ SHAWMUT may substitute A25X for 240 V frequency converters.

## 4 Quick Set-up

### 4.1 Programming Procedures

#### 4.1.1 Basic Programming Procedures

The following describes the basic procedure for running the frequency converter.

#### **CAUTION**

When the connections are made, the compressor starts automatically.

1. Connect the power supply to the terminals (L1, L2 and L3) of the frequency converter as shown in *chapter 3.3.4 Mains connection for B4, C1 and C3*.
2. Connect motor cable between the frequency converter (U, V & W) and Compressor (clockwise on terminal), see *chapter 3.3.5 Motor Compressor Connection*. (The connectors utilised in these first 2 steps are provided in the accessory bag which accompanies the frequency converter).
3. Press [Quick Menu] and go to quick set-up. Ensure that the correct compressor model is selected in *1-13 Compressor Selection*.
4. Connect terminal 12 with terminal 18 (start signal), terminal 12 with terminal 27 (inverse coast signal) and terminal 12 with terminal 37\* (safe stop inverse signal).

\*See *chapter 3.3.10 Basic Wiring Example* and *chapter 2.2.1 Terminal 37 Safe Torque Off Function*.

#### **CAUTION**

If an error trips the frequency converter, it automatically tries to restart the compressor after 30 s (unless the error is severe and causes a trip lock). See also *14-20 Reset Mode* and *14-21 Automatic Restart Time*.

#### 4.1.2 Open Loop with External Reference

1. Apply analog speed reference signal (0-10 V) on terminal 53 using the terminal 55 as common. See *chapter 3.3.15 Basic Examples of Control Connections*.
2. Check if switch A53 is positioned to U (voltage) instead of I (current). The switch A53 is on the frequency converter and is visible when the keypad is removed.

3. Ready to Run: If the frequency converter is supplied with display: Press [Hand On] to set a local speed reference in the display (good for testing purposes). Press [Auto On] for running in operation and with an external reference.

*Illustration 4.1* shows the screen after configuring the frequency converter for *Speed Open loop* application, *Hand On mode*.

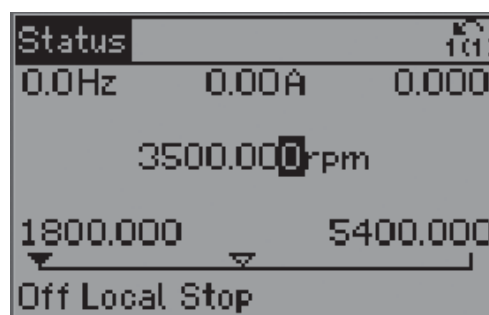

130BA554.10

Illustration 4.1 Speed Open Loop, Hand On Mode

This is what the screen will look like after configuring the frequency converter for *Speed Open loop* application, *Auto On mode*:

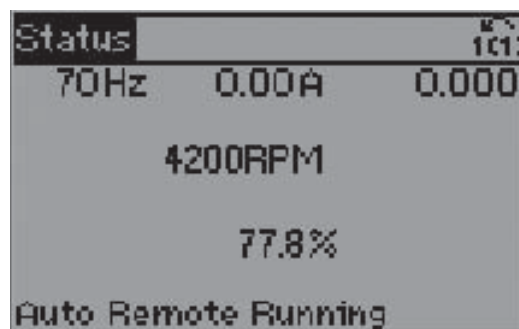

130BA555.10

Illustration 4.2 Speed Open Loop, Auto On Mode

4. Done.

#### 4.1.3 PID Closed Loop with 4-20 mA Pressure Transmitter

1. Connect pressure transmitter to analog input on terminal 54 according to *chapter 3.3.15 Basic Examples of Control Connections*.
2. Make sure that the switch for analogue input 54 is set to "I" for current input.

## Quick Set-up

3. Press [Quick Menu], go to "PID Closed Loop" and then to "Basic PID Settings) menu.  
Now change parameters to  
 1-00 Configuration Mode: Select [3] Process  
 3-01 Reference/Feedback Unit: Select [71] Bar  
 3-02 Minimum Reference and 3-03 Maximum Reference: Enter the lower and upper limits of the setpoint range [bar].  
 3-15 Reference Resource 1: Select [0] No function for fixed setpoint.  
 6-22 Terminal 54 Low Current + 6-23 Terminal 54 High Current: The values of these parameters should match the output of the pressure transmitter (4-20 mA for example is the factory setting).  
 6-24 Terminal 54 Low Ref./Feedb. Value + 6-25 Terminal 54 High Ref./Feedb. Value: Set range of pressure transmitter (factory setting -1/+12 bar)  
 Return to 3-13 Reference Site: Select [2] Local to run with a fixed setpoint adjustable via keypad. Select [1] Remote if the setpoint is given by the analog input (as defined in 3-15 Reference Resource 1).
4. Press [Quick Menu], go to My Personal Menu, go to 0-22 Display Line 1.3 Small and select [1652]

*Feedback [unit].* The pressure [bar] is going to be shown in the upper right corner of the display

This is what the screen will look like, after configuring the frequency converter for Closed loop application.

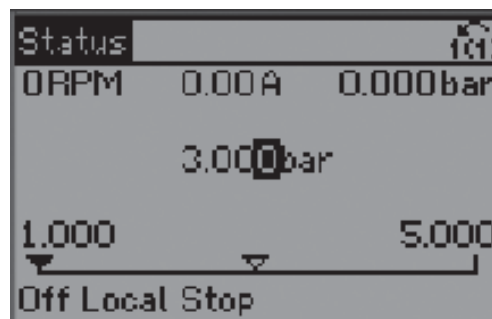

130BA556.10

Illustration 4.3 Closed Loop

5. Ready to Run: Press [Hand On] and set reference in bars using the arrows on the display. Before leaving the site, never forget the next step.
6. Ready to Run: Press [Auto On].

For more details on PID Closed Loop, see *Illustration 4.4*.

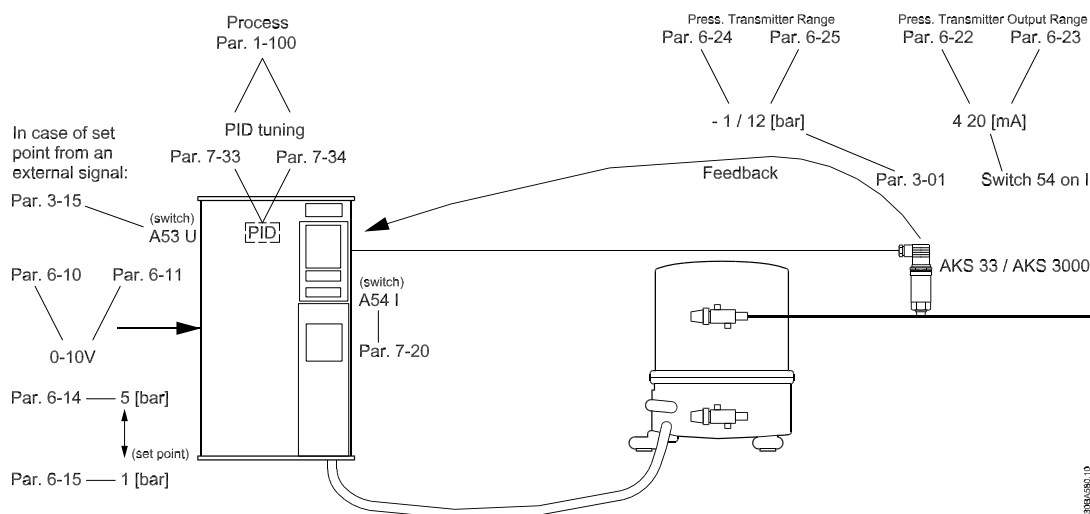

Illustration 4.4 Example of Closed Loop Application

### 4.1.4 Other Compressor Features

To set up other dedicated compressor features press [Quick Menu] and go to Q4 or follow *Illustration 4.5*.

4

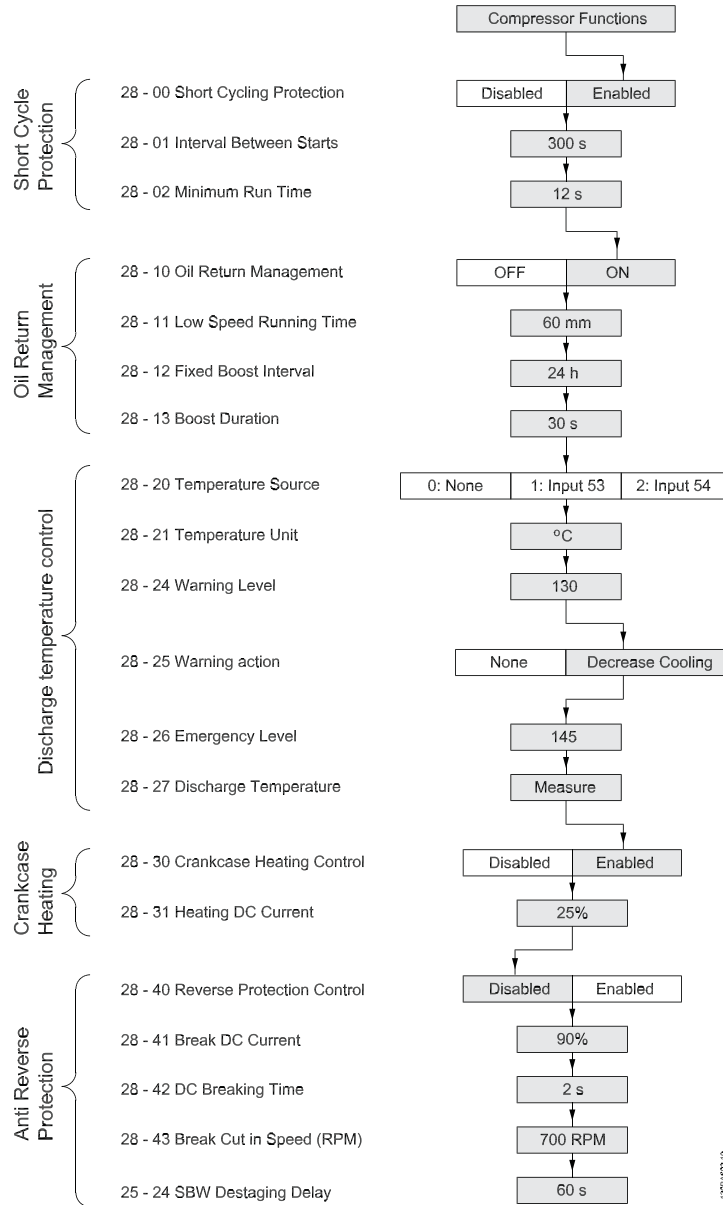

Illustration 4.5 Flowchart

## 5 How to Program

### 5.1 How to Program on the Graphical Keypad

**NOTE**

TRV200 frequency converter is completely setup at factory, requiring no programming unless debugging a drive or administering an engineering approved parameter change.

#### 5.1.1 Control Panel

The following instructions are valid for the graphical keypad:

The control panel is divided into four functional groups:

1. Graphical display with Status lines. All data is displayed in a graphical keypad display, which can show up to five items of operating data while displaying [Status].
2. Menu keys and indicator lights - changing parameters and switching between display functions.
3. Navigation keys and indicator lights (LEDs).
4. Operation keys and indicator lights (LEDs).

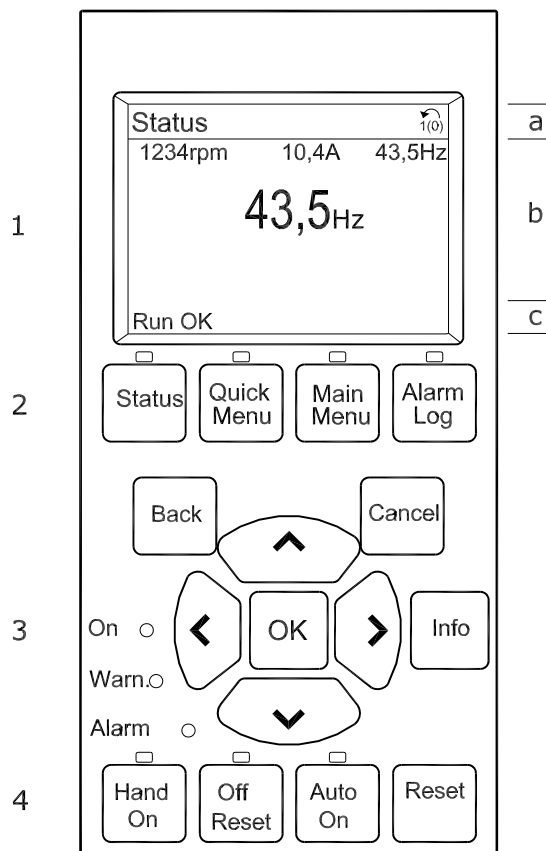

Illustration 5.1 Overview of Keypad

#### 5.1.2 Display Lines

**a. Status line:**

Status messages displaying icons and graphic.

**b. Line 1-2:**

Operator data lines displaying data defined or chosen by the user. By pressing the [Status] key, up to one extra line can be added.

**c. Status line:**

Status messages displaying text.

#### 5.1.3 Display Contrast Adjustment

Press [Status] and [▼] for darker display

Press [Status] and [▲] for brighter display



### 5.1.5 Indicator Lights

If certain threshold values are exceeded, the alarm and/or warning LED lights up. A status and alarm text appear on the control panel. The on LED is activated when the frequency converter receives mains voltage.

- Green LED/On: Control section is working.
- Yellow LED/Warn.: Indicates a warning.
- Flashing Red LED/Alarm: Indicates an alarm



Illustration 5.2 Indicator Lights

## 5.2 Keypad

### 5.2.1 Function Keys

The control keys are divided into functions. The keys below the display and indicator lamps are used for parameter set-up, including choice of display indication during normal operation.



Illustration 5.3 Function Keys

**[Status]** indicates the status of the frequency converter and/or the compressor motor. Choose between 3 different readouts by pressing the [Status] key: 5 line readouts, 4 line readouts or Smart Logic Control by pushing [Status] twice.

Press [Status] to select the display mode or to change back to Display mode from either Quick Menu mode, Main Menu mode or Alarm mode. Also press [Status] to toggle single or double read-out mode.

**[Quick Menu]** allows quick access to different Quick Menus such as:

- Q1 - My Personal Menu
- Q2 - Quick Set-up
- Q3 - PID Process Loop
- Q4 - Compressor Functions
- Q5 - Changes Made
- Q6 - Loggings
- Q7 - Load Profile

Use [Quick Menu] for programming the parameters belonging to the Quick Menu. It is possible to switch directly between Quick Menu mode and Main Menu mode.

### 5.2.2 Navigation Keys

The 4 navigation keys are used to navigate between the different choices available in [Quick Menu], [Main Menu] and [Alarm Log]. Press the keys to move the cursor. [OK] is used for choosing a parameter marked by the cursor and for enabling the change of a parameter and loggings from Quick Menu.

### 5.2.3 Local Control Keys

Local control keys for local control are found at the bottom of the control panel.

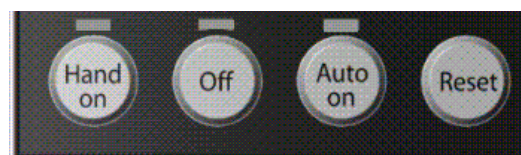

130BP046.10

Illustration 5.4 Local Control Keys

**[Hand On]** enables control of the frequency converter via the keypad. [Hand on] also starts the motor compressor, and it is now possible to enter the motor compressor speed data by means of the arrow keys. The key can be selected as [1] Enable or [0] Disable via 0-40 [Hand on] Key on LCP.

External stop signals activated by means of control signals or a serial bus will override a "start" command via the keypad.

The following control signals will still be active when [Hand on] is activated:

- [Hand On] - [Off] - [Auto On]
- Reset
- Coasting stop inverse
- Reversing

- Set-up select lsb (least significant bit) - Set-up select msb (most significant bit)
- Stop command from serial communication
- Quick stop
- DC brake

[Off] stops the connected motor compressor. The key can be selected as [1] Enable or [0] Disable via 0-41 [Off] Key on LCP.

If no external stop function is selected and the [Off] key is inactive the motor compressor can be stopped by disconnecting the voltage.

[Auto On] enables the frequency converter is to be controlled via the control terminals and/or serial communication. When a start signal is applied on the control terminals and/or the bus, the frequency converter will start. The key can be selected as [1] Enable or [0] Disable via 0-42 [Auto on] Key on LCP.

### **NOTICE**

An active HAND-OFF-AUTO signal via the digital inputs has higher priority than the control keys [Hand on] and [Auto on].

[Reset] is used for resetting the frequency converter after an alarm (trip). It can be selected as [1] Enable or [0] Disable via 0-43 [Reset] Key on LCP.

The **parameter shortcut** can be carried out by holding down the [Main Menu] key for 3 seconds. The parameter shortcut allows direct access to any parameter.

## 5.2.4 Quick Transfer of Parameter Settings

Once the set-up of a frequency converter is complete, store the data in the keypad or on a PC via Trane Drive Utility (TDU).

## 5.2.5 Data Storage in Keypad

1. Go to 0-50 LCP Copy in the Main Menu.
2. Press [OK].
3. Select [1] All to LCP.
4. Press [OK].

All parameter settings are now stored in the keypad indicated by the progress bar. When 100% is reached, press [OK].

### **NOTICE**

**Stop the motor compressor before performing this operation. The keypad can now be connected to another frequency converter and the parameter settings copied to this frequency converter as well.**

## 5.2.6 Initialisation to Default Settings

Initialise the frequency converter to default settings in two ways:

### **Recommended initialisation (via 14-22 Operation Mode)**

1. Select 14-22 Operation Mode.
2. Press [OK].
3. Select [2] Initialisation.
4. Press [OK].
5. Disconnect mains supply and wait until the display turns off.
6. Reconnect the mains supply.
7. Drive initialised [A80] (Alarm 80) appears - the frequency converter is now reset.

14-22 Operation Mode initialises all except:

- 8-30 Protocol
- 8-31 Address
- Parameter 8-32 FC Port Baud Rate
- Parameter 8-33 Parity / Stop Bits
- 8-34 Estimated cycle time
- Parameter 8-35 Minimum Response Delay
- Parameter 8-36 Max Response Delay
- Parameter 8-37 Max Inter-Char Delay
- 14-50 RFI Filter
- 15-00 Operating hours
- 15-01 Running Hours
- 15-02 kWh Counter
- 15-03 Power Up's
- 15-04 Over Temp's

- 15-05 Over Volt's
- 15-20 Historic Log: Event
- 15-21 Historic Log: Value
- 15-22 Historic Log: Time
- 15-30 Fault Log: Error Code
- 15-31 Fault Log: Value
- 15-32 Fault Log: Time

### Manual initialisation

1. Disconnect from mains and wait until the display turns off.
2. Press [Status] - [Main Menu] - [OK] at the same time while power up for Graphical Display.
3. Release the keys after 5 s.
4. The frequency converter is now programmed according to default settings.

This procedure initialises all except:

- 15-00 Operating hours
- 15-03 Power Up's
- 15-04 Over Temp's
- 15-05 Over Volt's

### 5.2.7 Data Transfer from Keypad to Frequency Converter

#### **NOTICE**

Stop the motor compressor before performing this operation.

1. Go to 0-50 LCP Copy.
2. Press [OK].
3. Select [2] All from LCP.
4. Press [OK] again.

The parameter settings stored in the keypad are now transferred to the frequency converter indicated by the progress bar. When 100% is reached, press [OK].

### 5.2.8 Parameter Selection

In the Main menu mode, the parameters are divided into groups. Use the navigation keys for selecting a parameter group.

The following parameter groups are accessible:

- 0-\*\* Operation/Display
- 1-\*\* Load/Motor
- 3-\*\* Reference/Ramps

- 4-\*\* Limits/Warnings
- 5-\*\* Digital In/Out
- 6-\*\* Analog In/Out
- 7-\*\* Controls
- 8-\*\* Comm. and Options
- 13-\*\* Smart Logic
- 14-\*\* Special Functions
- 15-\*\* Drive Information
- 16-\*\* Data Readouts
- 25-\*\* Cascade Controller
- 28-\*\* Compressor Functions

After selecting a parameter group, select a parameter with the navigation keys. The middle section on the display shows the parameter number and name as well as the selected parameter value.



Illustration 5.5 Display Example - Parameter Selection

### 5.2.9 Changing Data

The procedure for changing data is the same in both the Quick menu and the Main menu mode.

Press [OK] to change the selected parameter. The procedure for changing data depends on whether the selected parameter represents a numerical data value or a text value.

### 5.2.10 Changing a Text Value

If the selected parameter is a text value, change the text value by pressing the [▲]/[▼] navigation keys. [▲] increases the value and [▼] decreases the value. Place the cursor on the value and press [OK] to save.

### 5.2.11 Changing a Group of Numeric Data Values

If the chosen parameter represents a numeric data value, change it by pressing the navigation keys. Press [◀]/[▶] to move the cursor horizontally. Press [▲]/[▼] to change the data value. [▲] increases the data value, and [▼] decreases the data value. Place the cursor on the value and press [OK] to save.

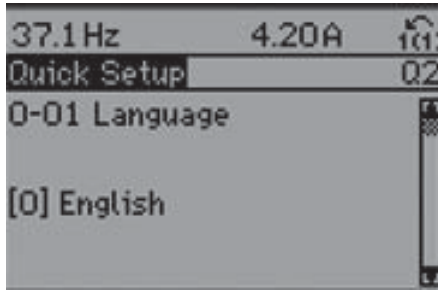

130BA562.10

Illustration 5.6 Display Example

## 6 Parameter Descriptions

### 6.1 Keypad Display

#### 6.1.1 Keypad Programming

Table 6.1 lists the parameters that cannot be changed from the keypad. These parameters are defined by the compressor choice made in 1-13 Compressor Selection.

Parameter	Parameter	Parameter
1-01 Motor Control Principle	1-45 q-axis Inductance (Lq) 200% I <sub>NOM</sub>	5-42 Off Delay, Relay
1-03 Torque Characteristics	1-40 Back EMF at 1000 RPM	7-00 Speed PID Feedback Source
1-04 Overload Mode	1-47 Torque Calibration	7-02 Speed PID Proportional Gain
1-05 Local Mode Configuration	1-49 Current at min. inductance	7-03 Speed PID Integral Time
1-10 Motor Construction	1-62 Slip Compensation	7-04 Speed PID Differentiation Time
1-20 Motor Power [kW]	1-66 Min. Current at Low Speed	7-05 Speed PID Diff. Gain Limit
1-22 Motor Voltage	1-68 Minimum Inertia	parameter 13-10 Comparator Operand
1-23 Motor Frequency	1-69 Maximum Inertia	parameter 13-11 Comparator Operator
1-24 Motor Current	1-71 Start Delay	13-12 Comparator Value
1-25 Motor Nominal Speed	1-72 Start Function	14-00 Switching Pattern
1-26 Motor Cont. Rated Torque	1-73 Flying Start	14-01 Switching Frequency
1-29 Automatic Motor Adaptation (AMA)	1-74 Start Speed [RPM]	14-10 Mains Failure
1-30 Stator Resistance (Rs)	1-76 Start Current	14-11 Mains Voltage at Mains Fault
1-31 Rotor Resistance (Rr)	1-77 Compressor Start Min Speed [RPM]	14-21 Automatic Restart Time
1-33 Stator Leakage Reactance (X1)	1-79 Compressor Start Max Time to Trip	14-25 Trip Delay at Torque Limit
1-34 Rotor Leakage Reactance (X2)	1-86 Compressor Min. Speed for Trip [RPM]	14-26 Trip Delay at Inverter Fault
1-35 Main Reactance (Xh)	3-82 Starting Ramp Up Time	28-30 Crankcase Heating Control
1-36 Iron Loss Resistance (Rfe)	4-10 Motor Speed Direction	28-31 Heating DC Current
1-37 d-axis Inductance (Ld)	4-11 Motor Speed Low Limit [RPM]	28-40 Reverse Protection Control
1-38 q-axis Inductance (Lq)	4-13 Motor Speed High Limit [RPM]	28-41 DC Brake Current
1-39 Motor Poles	4-16 Torque Limit Motor Mode	28-42 DC Braking Time
1-40 Back EMF at 1000 RPM	4-19 Max Output Frequency	28-43 DC Brake Cut In Speed [RPM]
1-44 d-axis Inductance (Ld) 200% I <sub>NOM</sub>	5-41 On Delay, Relay	

Table 6.1 Compressor Related Parameters

### 6.2 Parameters: 0-\*\* Operation and Display

#### 6.2.1 0-0\* Basic Settings

0-01 Language		
Option:	Function:	
[0] *	English	
[1]	Deutsch	
[2]	Francais	
[3]	Dansk	
[4]	Spanish	
[5]	Italiano	
[10]	Chinese	
[28]	Bras.port	
[39]	Korean	
[42]	Trad.Chinese	
[49]	Russian	

0-02 Motor Speed Unit		
Option:	Function:	
[0] *	RPM	Select display of motor speed parameters (i.e. references, feedbacks and limits) in terms of shaft speed (RPM) or output frequency to the motor (Hz).
[1]	Hz	

#### **NOTICE**

This parameter cannot be adjusted while the motor is running.

## Parameter Descriptions

0-04 Operating State at Power-up (Hand)		
Option:	Function:	
		Selects the operating mode upon reconnection of the frequency converter to mains voltage after power down in Hand (local) operation mode.
[0]	Resume	Restarts the frequency converter, maintaining the same and the same start/stop settings (applied by [Hand On/Off]) as before the frequency converter was powered down.
[1] *	Forced stop, ref=old	Restarts the frequency converter with a saved local reference, after mains voltage reappears and after pressing [Hand On].
[2]	Forced stop, ref=0	Resets the local reference to 0 upon restarting the frequency converter.

0-10 Active Set-up		
Option:	Function:	
		Select the set-up to control the frequency converter functions.
[0]	Factory setup	Cannot be changed. It contains the Trane data set, and can be used as a data source when returning the other set-ups to a known state.
[1] *	Set-up 1	[1] Set-up 1 to [4] Set-up 4 are the 4 separate parameter set-ups within which all parameters can be programmed.
[2]	Set-up 2	
[3]	Set-up 3	
[4]	Set-up 4	
[9]	Multi Set-up	Remote selection of set-ups using digital inputs and the serial communication port. This set-up uses the settings from <i>parameter 0-12 This Set-up Linked to</i> . Stop the frequency converter before making changes to open- and closed loop functions

Use *0-51 Set-up Copy* to copy a set-up to one or all other set-ups. Stop the frequency converter before switching between set-ups where parameters marked 'not changeable during operation' have different values. To avoid conflicting settings of the same parameter within 2 different set-ups, link the set-ups together using *parameter 0-12 This Set-up Linked to*. Parameters which are 'not changeable during operation' are marked FALSE in the parameter lists in *chapter 6.16 Parameter Lists*.

0-11 Edit Set-up		
Option:	Function:	
		Select the set-up to be edited (i.e. programmed) during operation; either the active set-up or one of the inactive set-ups.
[0]	Factory setup	Cannot be edited but it is useful as a data source to return the other set-ups to a known state.

0-11 Edit Set-up		
Option:	Function:	
[1] *	Set-up 1	[1] Set-up 1 to [4] Set-up 4 can be edited freely during operation, independently of the active set-up.
[2]	Set-up 2	
[3]	Set-up 3	
[4]	Set-up 4	
[9]	Active Set-up	Can also be edited during operation. Edit the selected set-up from a range of sources: Keypad, FC RS-485, FC USB or up to 5 fieldbus sites.

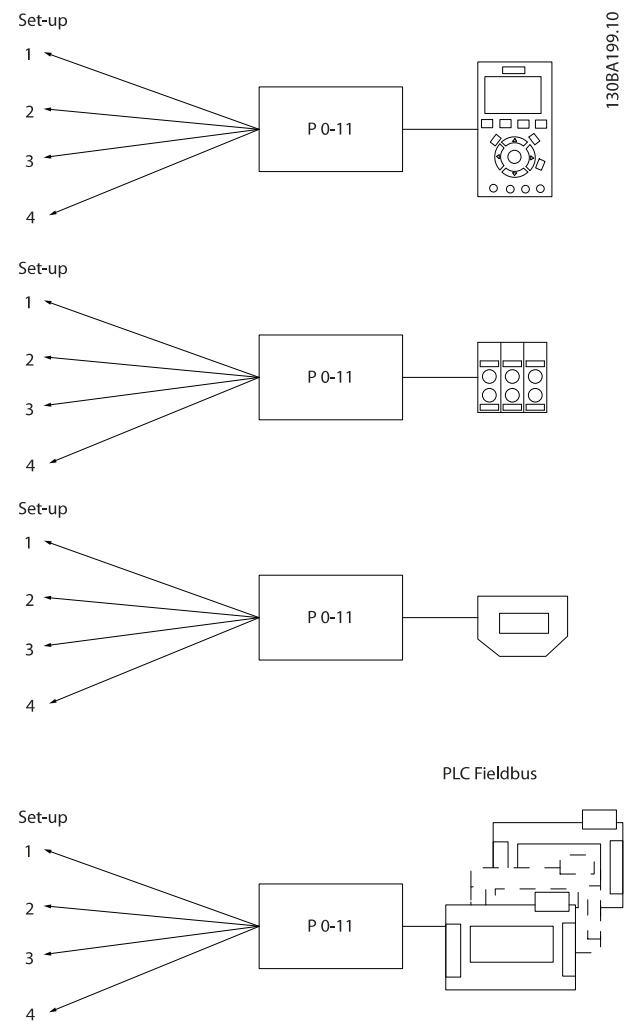
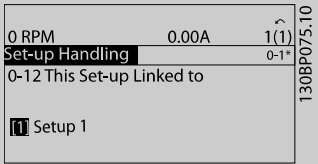
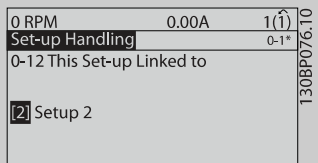

Illustration 6.1 Edit Set-up

0-12 This Set-up Linked to		
Option:	Function:	
		To enable conflict-free changes from one set-up to another during operation, link set-ups containing parameters which are not changeable during operation. The link ensures synchronising of the 'not changeable during

0-12 This Set-up Linked to	
Option:	Function:
	<p>operation' parameter values when moving from one set-up to another during operation. 'Not changeable during operation' parameters can be identified by the label FALSE in the parameter lists in <i>chapter 6.16 Parameter Lists</i>.</p> <p><i>Parameter 0-12 This Set-up Linked to</i> is used by Multi set-up in <i>parameter 0-10 Active Set-up</i>. Multi set-up is used to move from one set-up to another during operation (i.e. while the motor is running).</p> <p>Example: Use Multi set-up to shift from Set-up 1 to Set-up 2 whilst the motor is running. Programme in Set-up 1 first, then ensure that Set-up 1 and Set-up 2 are synchronised (or 'linked'). Synchronisation can be performed in 2 ways:</p> <ol style="list-style-type: none"> <li>1. Change the edit set-up to [2] Set-up 2 in <i>parameter 0-11 Edit Set-up</i> and set <i>parameter 0-12 This Set-up Linked to</i> to [1] Set-up 1. This starts the linking (synchronising) process.</li> </ol>  <p><b>Illustration 6.2 Set-up 1</b></p> <p>OR</p> <ol style="list-style-type: none"> <li>2. While still in Set-up 1, copy Set-up 1 to Set-up 2. Then set <i>parameter 0-12 This Set-up Linked to</i> to [2] Set-up 2. This starts the linking process.</li> </ol>  <p><b>Illustration 6.3 Set-up 2</b></p> <p>After the link is complete, <i>parameter 0-13 Readout: Linked Set-ups</i> reads {1,2} to indicate that all 'not changeable during operation' parameters are now the same in Set-up 1 and Set-up 2. If there are changes to a 'not changeable during operation' parameter, e.g. <i>1-30 Stator Resistance (Rs)</i>, in Set-up 2, they are also changed automatically in Set-up 1. A switch between Set-up 1 and Set-up 2 during operation is now possible.</p>
[0] *	Not linked

0-12 This Set-up Linked to	
Option:	Function:
[1]	Set-up 1
[2]	Set-up 2
[3]	Set-up 3
[4]	Set-up 4

0-13 Readout: Linked Set-ups													
Range:	Function:												
0* [0 - 255 ]	<p>View a list of all the set-ups linked by means of <i>0-12 This Set-up Linked to</i>. The parameter has one index for each parameter set-up. The parameter value displayed for each index represents which set-ups are linked to that parameter set-up.</p> <table border="1"> <thead> <tr> <th>Index</th> <th>Keypad value</th> </tr> </thead> <tbody> <tr> <td>0</td> <td>{0}</td> </tr> <tr> <td>1</td> <td>{1,2}</td> </tr> <tr> <td>2</td> <td>{1,2}</td> </tr> <tr> <td>3</td> <td>{3}</td> </tr> <tr> <td>4</td> <td>{4}</td> </tr> </tbody> </table> <p><b>Table 6.3 Example: Set-up 1 and Set-up 2 are linked</b></p>	Index	Keypad value	0	{0}	1	{1,2}	2	{1,2}	3	{3}	4	{4}
Index	Keypad value												
0	{0}												
1	{1,2}												
2	{1,2}												
3	{3}												
4	{4}												

0-14 Readout: Edit Set-ups / Channel	
Range:	Function:
0* [-2147483648 - 2147483647 ]	<p>View the setting of <i>parameter 0-11 Edit Set-up</i> for each of the 4 different communication channels. When the number is displayed as a hex number, as it is in the keypad, each number represents one channel.</p> <p>Numbers 1-4 represent a set-up number; 'F' means factory setting; and 'A' means active set-up. The channels are, from right to left: keypad, FC-bus, USB, HPFB1-5.</p> <p>Example: The number AAAAAA21h means that the FC bus selected Set-up 2 in <i>parameter 0-11 Edit Set-up</i>, the keypad selected Set-up 1 and all others used the active set-up.</p>

### 6.2.2 0-2\* LCP Display

Define the display in the Graphical Logic Control Panel.

0-20 Display Line 1.1 Small		
Option:		Function:
		Select a variable for display in line 1, left position.
[0]	None	
[953]	Profibus Warning Word	
[1005]	Readout Transmit Error Counter	

## Parameter Descriptions

0-20 Display Line 1.1 Small		
Option:	Function:	
[1006]	Readout Receive Error Counter	
[1007]	Readout Bus Off Counter	
[1013]	Warning Parameter	
[1501]	Running Hours	
[1502]	kWh Counter	
[1508]	Number of Starts	
[1509]	Number of Auto Resets	
[1600]	Control Word	
[1601]	Reference [Unit]	
[1602]	Reference %	
[1603]	Status Word	
[1605]	Main Actual Value [%]	
[1609]	Custom Readout	
[1610]	Power [kW]	
[1611]	Power [hp]	
[1612]	Motor Voltage	
[1613]	Frequency	
[1614]	Motor current	
[1615]	Frequency [%]	
[1616]	Torque [Nm]	
[1617]	Speed [RPM]	
[1618]	Motor Thermal	
[1619]	KTY sensor temperature	
[1620]	Motor Angle	
[1622]	Torque [%]	
[1630]	DC Link Voltage	
[1632]	Brake Energy /s	
[1633]	Brake Energy /2 min	
[1634]	Heatsink Temp.	
[1635]	Inverter Thermal	
[1636]	Inv. Nom. Current	
[1637]	Inv. Max. Current	
[1638]	SL Controller State	
[1639]	Control Card Temp.	
[1650]	External Reference	
[1651]	Pulse Reference	
[1652]	Feedback[Unit]	
[1653]	Digi Pot Reference	
[1654]	Feedback 1 [Unit]	
[1655]	Feedback 2 [Unit]	
[1660]	Digital Input	
[1661]	Terminal 53 Switch Setting	
[1662] *	Analog Input 53	
[1663]	Terminal 54 Switch Setting	
[1664]	Analog Input 54	
[1665]	Analog Output 42 [mA]	
[1666]	Digital Output [bin]	
[1667]	Freq. Input #29 [Hz]	
[1668]	Freq. Input #33 [Hz]	
[1669]	Pulse Output #27 [Hz]	
[1670]	Pulse Output #29 [Hz]	
[1671]	Relay Output [bin]	

0-20 Display Line 1.1 Small		
Option:	Function:	
[1672]	Counter A	
[1673]	Counter B	
[1680]	Fieldbus CTW 1	
[1682]	Fieldbus REF 1	
[1684]	Comm. Option STW	
[1685]	FC Port CTW 1	
[1686]	FC Port REF 1	
[1690]	Alarm Word	
[1691]	Alarm Word 2	
[1692]	Warning Word	
[1693]	Warning Word 2	
[1694]	Ext. Status Word	
[2580]	Cascade Status	
[2581]	Compressor Status	
[2587]	Inverse Interlock	
[2827]	Discharge Temperature	

0-21 Display Line 1.2 Small		
Option:	Function:	
		Options are the same as in <i>0-20 Display Line 1.1 Small</i>
[1614] *	Motor Current [A]	

0-22 Display Line 1.3 Small		
Option:	Function:	
		Options are the same as in <i>0-20 Display Line 1.1 Small</i> .
[1610] *	Power [kW]	

0-23 Display Line 2 Large		
Option:	Function:	
		Options are the same as in <i>0-20 Display Line 1.1 Small</i> .
[1613] *	Frequency [Hz]	

0-24 Display Line 3 Large		
Option:	Function:	
		Options are the same as in <i>0-20 Display Line 1.1 Small</i> .
[1662] *	Analog Input 53	

0-25 My Personal Menu		
Range:	Function:	
Size related*	[0 - 9999 ]	Define up to 20 parameters to include in the Q1 Personal Menu, accessible via the [Quick Menu] key on the keypad. The parameters will be displayed in the Q1 Personal Menu in the order they are programmed into this array parameter. Delete parameters by setting the value to « 0000 ».



## Parameter Descriptions

### 6.2.3 0-3\* LCP Custom Readout

It is possible to customise the display elements for various purposes: \*Custom Readout. Value proportional to speed (Linear, squared or cubed depending on unit selected in 0-30 Custom Readout Unit) \*Display Text. Text string stored in a parameter.

#### Custom readout

The calculated value to be displayed is based on settings in

- 0-30 Custom Readout Unit
- 0-31 Custom Readout Min Value (linear only)
- Parameter 0-32 Custom Readout Max Value
- 4-13 Motor Speed High Limit [RPM]
- 4-14 Motor Speed High Limit [Hz]
- and actual speed

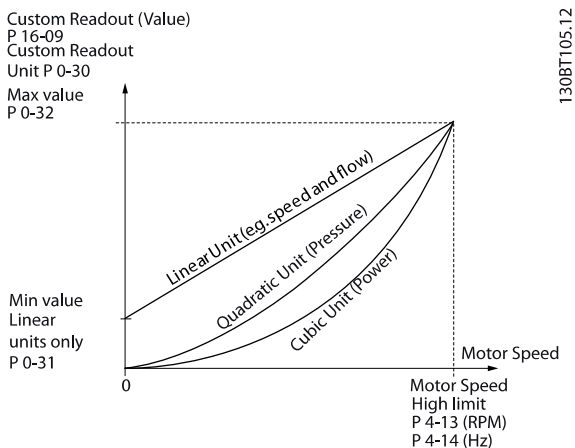

Illustration 6.4 Custom Readout

The relation depends on the type of unit selected in 0-30 Custom Readout Unit:

Unit Type	Speed Relation
Dimensionless	Linear
Speed	
Flow, volume	
Flow, mass	
Velocity	
Length	
Temperature	
Pressure	Quadratic
Power	Cubic

Table 6.4 Speed Relations for Different Unit Types

0-30 Unit for User-defined Readout	
Option:	Function:
	It is possible to program a value to be shown in the display of the keypad. The value has a linear, squared or cubed relation to speed. This relation depends on the unit selected (see Table 6.4). The actual calculated value can be read in parameter 16-09 Custom Readout, and/or shown in the display by selecting [16-09] Custom Readout in 0-20 Display Line 1.1 Small to 0-24 Display Line 3 Large.
[0] *	None
[1]	%
[5]	PPM
[10]	1/min
[11]	rpm
[12]	Pulse/s
[20]	l/s
[21]	l/min
[22]	l/h
[23]	m <sup>3</sup> /s
[24]	m <sup>3</sup> /min
[25]	m <sup>3</sup> /h
[30]	kg/s
[31]	kg/min
[32]	kg/h
[33]	t/min
[34]	t/h
[40]	m/s
[41]	m/min
[45]	m
[60]	°C
[70]	mbar
[71]	bar
[72]	Pa
[73]	kPa
[74]	m WG
[80]	kW
[120]	GPM
[121]	gal/s
[122]	gal/min
[123]	gal/h
[124]	CFM
[125]	ft <sup>3</sup> /s
[126]	ft <sup>3</sup> /min
[127]	ft <sup>3</sup> /h
[130]	lb/s
[131]	lb/min
[132]	lb/h
[140]	ft/s
[141]	ft/min
[145]	ft
[160]	°F
[170]	psi

## Parameter Descriptions

0-30 Unit for User-defined Readout		
Option:	Function:	
[171]	lb/in <sup>2</sup>	
[172]	in WG	
[173]	ft WG	
[180]	HP	

0-31 Min Value of User-defined Readout		
Range:	Function:	
0 CustomReadoutUnit*	[ -999999.99 - par. 0-32 CustomReadoutUnit]	This parameter sets the min. value of the custom defined readout (occurs at zero speed). Only possible to set different from 0 is when selecting a linear unit in <i>parameter 0-30 Unit for User-defined Readout</i> . For Quadratic and Cubic units the minimum value will be 0.

0-32 Custom Readout Max Value		
Range:	Function:	
100 CustomReadoutUnit*	[ par. 0-31 - 999999.99 CustomReadoutUnit]	This parameter sets the max value to be shown when the speed of the motor has reached the set value for <i>4-13 Motor Speed High Limit [RPM]</i> or <i>4-14 Motor Speed High Limit [Hz]</i> (depends on setting in <i>0-02 Motor Speed Unit</i> ).

### 6.2.4 0-4\* LCP Keypad

Enable and disable individual keys on the LCP keypad.

0-40 [Hand on] Key on LCP		
Option:	Function:	
		If <i>0-40 [Hand on] Key on LCP</i> is included in the Quick Menu, then define the password in <i>0-65 Quick Menu Password</i> .
[0] *	Disabled	Prevents accidental start of the frequency converter in Hand mode.
[1]	Enabled	Prevents unauthorised start in Hand mode.
[2]	Password	

0-41 [Off] Key on LCP		
Option:	Function:	
		Options are the same as in <i>0-40 [Hand on] Key on LCP</i> .

0-42 [Auto on] Key on LCP		
Option:	Function:	
		Options are the same as in <i>0-40 [Hand on] Key on LCP</i> .

0-43 [Reset] Key on LCP		
Option:	Function:	
		Options are the same as in <i>0-40 [Hand on] Key on LCP</i> .

### 6.2.5 0-5\* Copy/Save

Copy parameter settings between set-ups and to/from the LCP.

0-50 LCP Copy		
Option:	Function:	
[0] *	No copy	
[1]	All to LCP	Copies all parameters in all set-ups from the frequency converter memory to the LCP memory.
[2]	All from LCP	Copies all parameters in all set-ups from the LCP memory to the frequency converter memory.
[3]	Size indep. from LCP	Copies only the parameters that are independent of the motor size.

0-51 Set-up Copy		
Option:	Function:	
[0]	No copy	
[1]	Copy to set-up 1	Copies all parameters in the present edit set-up (defined in par. 0-11 Edit Set-up) to Set-up 1. Likewise, select the option corresponding to the other set-up(s).
[2]	Copy to set-up 2	
[3]	Copy to set-up 3	
[4]	Copy to set-up 4	
[9]	Copy to all	Copies the parameters in the present set-up over to each of the set-ups 1 to 4.

### 6.2.6 0-6\* Password

Define password access to menus.

0-60 Main Menu Password		
Option:	Function:	
[Size related] *		Define the password for access to the Main Menu via the [Main Menu] key. If <i>0-61 Access to Main Menu w/o Password</i> is set to [0] Full access, this parameter will be ignored.

0-61 Access to Main Menu w/o Password		
Option:	Function:	
		<b>NOTICE</b> If [0] Full access is selected, <i>0-60 Main Menu Password</i> , <i>0-65 Quick Menu Password</i> and <i>0-66 Access to Quick Menu w/o Password</i> are ignored.
[0]	Full access	Disables the password defined in <i>0-60 Main Menu Password</i> .

## Parameter Descriptions

### 0-61 Access to Main Menu w/o Password

Option:		Function:
[1] *	LCP: Read only	Prevents unauthorised editing of Main Menu parameters.
[2]	LCP: No access	Prevents unauthorised viewing and editing of Main Menu parameters.

### 0-65 Quick Menu Password

**Option: Function:**

		Define the password for access to the Quick Menu via the [Quick Menu] key. If <i>0-66 Access to Quick Menu w/o Password</i> is set to [0] Full access, this parameter will be ignored.
--	--	--

### 0-66 Access to Quick Menu w/o Password

**Option: Function:**

		<b>NOTICE</b> If <i>0-61 Access to Main Menu w/o Password</i> is set to [0] Full access, this parameter will be ignored.
[0] *	Full access	Disables the password defined in <i>0-65 Quick Menu Password</i> .
[1]	Read only	Prevents unauthorised editing of Quick Menu parameters.
[2]	No access	Prevents unauthorised viewing and editing of Quick Menu parameters.

### 6.3 Parameters: 1-\*\* Load and Motor

#### 6.3.1 1-0\* General Settings

Define whether the frequency converter operates in speed mode or torque mode; and whether the internal PID control should be active or not. All parameters from 1-01 Motor Control Principle (included) to 1-81 Min Speed for Function at Stop [RPM] (included) are read only. Only 1-13 Compressor Selection remains accessible for compressor selection.

##### 1-00 Configuration Mode

Option:	Function:
	<p><b>NOTICE</b></p> <p>This parameter cannot be adjusted while the motor is running.</p>
	Select the application control principle to be used when a Remote Reference (via analog input) is active. A Remote Reference can only be active when 3-13 Reference Site is set to [0] or [1].
[0] *	Speed open loop Enables speed control (without feedback signal from motor) to the input signal over the compressor speed range.
[3]	Process Enables the use of process control in the frequency converter. The process control parameters are set in parameter groups 7-2* Process PID Feedback and 7-3* Process PID Control.

##### 1-13 Compressor Selection

Range:	Function:
	<p>The default setting of most of the parameters in the frequency converter (e.g. motor data, limits, ramps etc.) depends upon the compressor and system refrigerant selected for the frequency converter.</p> <p>The frequency converter selects the default compressor based upon the power size and voltage range for the frequency converter. Under normal circumstances this should not be changed. During test/repair situations a different compressor can be selected – or if the system is not using the default refrigerant.</p> <p><b>NOTICE</b></p> <p>If the compressor selection is changed, then all dependent parameters reset to default and any user settings will be lost.</p>
Size dependent.	<input type="checkbox"/> Select the compressor/refrigerant combination for the system.

## 6.4 Parameters: 3-\*\*-\*\* Reference/Ramps

### 6.4.1 3-0\* Reference Limits

Parameters for reference handling, definition of limitations, and configuration of the reaction of the frequency converter to changes.

#### 3-00 Reference Range

Option:	Function:
	Select the range of the reference signal and the feedback signal. Signal values can be positive only, or positive and negative. The minimum limit may have a negative value, unless [1] <i>Speed closed loop</i> control is selected in 1-00 <i>Configuration Mode</i> .
[0] *	Min. - Max
[1]	-Max - +Max

#### 3-01 Reference/Feedback Unit

Option:	Function:
	Select the unit to be used in Process PID Control references and feedbacks.
[0]	None
[71] *	bar
[60]	°C
[160]	°F
[170]	psi

#### 3-02 Minimum Reference

Option:	Function:
	Enter the minimum reference. The minimum reference is the lowest value obtainable by summing all references. Minimum reference is active only when 3-00 <i>Reference Range</i> is set to [0] <i>Min.- Max.</i>
	<p><b>The minimum reference unit matches:</b></p> <ul style="list-style-type: none"> <li>The choice of configuration in 1-00 <i>Configuration Mode</i>: for [1] <i>Speed closed loop</i>.</li> <li>The unit selected in 3-01 <i>Reference/Feedback Unit</i>.</li> </ul>

#### 3-03 Maximum Reference

Option:	Function:
	Enter the maximum reference.

#### 3-10 Preset Reference

Array [8]

0.00%*	[-100.00 - 100.00 %]	Must remain 0 for Open Loop Control. The preset reference is stated as a percentage of the value Ref <sub>MAX</sub> (3-03 <i>Maximum Reference</i> ) or as a percentage of the other external references. If a Ref <sub>MIN</sub> 0 (3-02 <i>Minimum Reference</i> ) is programmed, the
--------	----------------------	---

		<p>preset reference is calculated as a percentage of the full reference range, i.e. on the basis of the difference between Ref<sub>MAX</sub> and Ref<sub>MIN</sub>. Afterwards, the value is added to Ref<sub>MIN</sub>. When using preset references, select [16] <i>Preset ref. bit 0</i>, [17] <i>Preset ref. bit 1</i> or [18] <i>Preset ref. bit 2</i> for the corresponding digital inputs in parameter group 5-1* <i>Digital Inputs</i>.</p>
--	--	---

#### 3-12 Catch up/slow Down Value

Range:	Function:
0 %* [0 - 100 %]	Enter a percentage (relative) value to be either added to or deducted from the actual reference for Catch up or Slow down respectively. If <i>Catch up</i> is selected via one of the digital inputs (5-10 <i>Terminal 18 Digital Input</i> to 5-15 <i>Terminal 33 Digital Input</i> ), the percentage (relative) value is added to the total reference. If <i>Slow down</i> is selected via one of the digital inputs (5-10 <i>Terminal 18 Digital Input</i> to 5-15 <i>Terminal 33 Digital Input</i> ), the percentage (relative) value is deducted from the total reference. Obtain extended functionality with the DigiPot function. See parameter group 3-9* <i>Digital Potentiometer</i> .

#### 3-13 Reference Site

Option:	Function:
	Select which reference site to activate.
[0]	Linked to Hand / Auto
[1]	Remote
[2]	Local

#### 3-14 Preset Relative Reference

Range:	Function:
0.00%* [-100.00 - 100.00 %]	Define a fixed value (in %) to be added to the variable value (defined in 3-18 <i>Relative Scaling Reference Source</i> ). The sum of the fixed and variable values is multiplied with the actual reference. This product is then added to the actual reference (X+X*Y/100) to give the resultant actual reference.

#### 3-15 Reference Resource 1

Option:	Function:
	<b>NOTICE</b> This parameter cannot be adjusted while the motor is running.
	Select the reference input to be used for the first reference signal. 3-15 <i>Reference Resource 1</i> , 3-16 <i>Reference Resource 2</i> and

## Parameter Descriptions

3-15 Reference Resource 1		
Option:	Function:	
		3-17 Reference Resource 3 define up to three different reference signals. The sum of these reference signals defines the actual reference.
[0]	No function	
[1] *	Analog input 53	
[2]	Analog input 54	
[7]	Frequency input 29	
[8]	Frequency input 33	
[11]	Local bus reference	
[20]	Digital pot.meter	

3-16 Reference Resource 2		
Option:	Function:	
		<b>NOTICE</b> This parameter cannot be adjusted while the motor is running.
		Select the reference input to be used for the second reference signal. Parameters 3-15 Reference Resource 1, 3-16 Reference Resource 2 and 3-17 Reference Resource 3 define up to three different reference signals. The sum of these reference signals defines the actual reference. Same options as 3-15 Reference Resource 1.
[0] *	No function	

3-17 Reference Resource 3		
Option:	Function:	
		<b>NOTICE</b> This parameter cannot be adjusted while the motor is running.
		Select the reference input to be used for the third reference signal. 3-15 Reference Resource 1, 3-16 Reference Resource 2 and 3-17 Reference Resource 3 define up to three different reference signals. The sum of these reference signals defines the actual reference. Same options as 3-15 Reference Resource 1.
[0] *	No function	

3-18 Relative Scaling Reference Resource		
Option:	Function:	
		Select a variable value to be added to the fixed value (defined in 3-14 Preset Relative Reference). The sum of the fixed and variable values is multiplied with the actual reference. This product is then added to the actual reference ( $X+X*Y/100$ ) to give the resultant actual reference Same options as 3-15 Reference Resource 1.

3-18 Relative Scaling Reference Resource		
Option:	Function:	
[0] *	No function	

3-19 Jog Speed [RPM]		
Range:	Function:	
Size related*	[ 0 - par. 4-13 RPM]	Enter a value for the jog speed $n_{JOG}$ , which is a fixed output speed. The frequency converter runs at this speed when the jog function is activated. The maximum limit is defined in 4-13 Motor Speed High Limit [RPM]. See also parameter 3-80 Jog Ramp Time.

3-40 Ramp 1 Type		
Option:	Function:	
		Select the ramp type, depending on requirements for acceleration/deceleration. A linear ramp will give constant acceleration during ramping.
[0] *	Linear	

Range:	Function:

3-50 Ramp 2 Type		
Option:	Function:	
		Select the ramp type, depending on requirements for acceleration/deceleration. A linear ramp gives constant acceleration during ramping. An S-ramp gives non-linear acceleration, compensating for jerk in the application.
[0] *	Linear	
[1]	S-ramp Const Jerk	Acceleration with lowest possible jerk
[2]	S-ramp Const Time	S-ramp based on the values set in parameter 3-51 Ramp 2 Ramp Up Time and parameter 3-52 Ramp 2 Ramp Down Time

### NOTICE

If [1] S-ramp Const Jerk is selected and the reference during ramping is changed the ramp time may be prolonged to realise a jerk-free movement, which may result in a longer start or stop time. Additional adjustment of the S-ramp ratios or switching initiators may be necessary.

3-51 Ramp 2 Ramp Up Time		
Range:	Function:	
Size related*	[ 0.01 - 3600 s]	Enter the ramp-up time, i.e. the acceleration time from 0 RPM to the rated motor speed $n_s$ . Select a ramp-up time such that the

## Parameter Descriptions

6

3-51 Ramp 2 Ramp Up Time		
Range:		Function:
		output current does not exceed the current limit in <i>parameter 4-18 Current Limit</i> during ramping. The value 0.00 corresponds to 0.01 s in speed mode. See ramp-down time in <i>parameter 3-52 Ramp 2 Ramp Down Time</i> .
$Par. 3-51 = \frac{t_{acc} [s] \times n_s [RPM]}{ref [RPM]}$		

3-52 Ramp 2 Ramp Down Time		
Range:		Function:
Size related*	[ 0.01 - 3600 s]	Enter the ramp-down time, i.e. the deceleration time from the rated motor speed $n_s$ to 0 RPM. Select a ramp-down time such that no overvoltage arises in the frequency converter due to regenerative operation of the motor, and such that the generated current does not exceed the current limit set in <i>parameter 4-18 Current Limit</i> . The value 0.00 corresponds to 0.01 s in speed mode. See ramp-up time in <i>parameter 3-51 Ramp 2 Ramp Up Time</i> .
$Par. 3-52 = \frac{t_{dec} [s] \times n_s [RPM]}{ref [RPM]}$		

3-60 Ramp 3 Type		
Option:		Function:
		Select the ramp type, depending on requirements for acceleration and deceleration. A linear ramp gives constant acceleration during ramping. An S-ramp gives non-linear acceleration, compensating for jerk in the application.
[0] *	Linear	
[1]	S-ramp Const Jerk	Accelerates with lowest possible jerk.
[2]	S-ramp Const Time	S-ramp based on the values set in <i>parameter 3-61 Ramp 3 Ramp up Time</i> and <i>parameter 3-62 Ramp 3 Ramp down Time</i>

### NOTICE

If [1] *S-ramp Const Jerk* is selected and the reference during ramping is changed, the ramp time may be prolonged to realise a jerk-free movement which may result in a longer start or stop time. Additional adjustment of the S-ramp ratios or switching initiators may be necessary.

3-61 Ramp 3 Ramp up Time		
Range:		Function:
Size related*	[ 0.01 - 3600 s]	Enter the ramp-up time, i.e. the acceleration time from 0 RPM to the rated motor speed $n_s$ . Select a ramp-up time such that the output current does not exceed the current

3-61 Ramp 3 Ramp up Time		
Range:		Function:
		limit in <i>parameter 4-18 Current Limit</i> during ramping. The value 0.00 corresponds to 0.01 s in speed mode. See ramp-down time in <i>parameter 3-62 Ramp 3 Ramp down Time</i> .

3-62 Ramp 3 Ramp down Time		
Range:		Function:
Size related*	[ 0.01 - 3600 s]	Enter the ramp-down time, i.e. the deceleration time from the rated motor speed $n_s$ to 0 RPM. Select a ramp-down time such that no overvoltage arises in the inverter due to regenerative operation of the motor, and such that the generated current does not exceed the current limit set in <i>parameter 4-18 Current Limit</i> . The value 0.00 corresponds to 0.01 s in speed mode. See ramp-up time in <i>parameter 3-61 Ramp 3 Ramp up Time</i> .
$Par. 3-62 = \frac{t_{dec} [s] \times n_s [RPM]}{ref [RPM]}$		

3-70 Ramp 4 Type		
Option:		Function:
		Select the ramp type, depending on requirements for acceleration and deceleration. A linear ramp gives constant acceleration during ramping. An S-ramp gives non-linear acceleration, compensating for jerk in the application
[0] *	Linear	
[1]	S-ramp Const Jerk	Accelerates with lowest possible jerk.
[2]	S-ramp Const Time	S-ramp based on the values set in <i>parameter 3-71 Ramp 4 Ramp up Time</i> and <i>parameter 3-72 Ramp 4 Ramp Down Time</i> .

### NOTICE

If [1] *S-ramp Const Jerk* is selected and the reference during ramping is changed, the ramp time may be prolonged to realise a jerk-free movement which may result in a longer start or stop time. Additional adjustment of the S-ramp ratios or switching initiators may be necessary.

3-71 Ramp 4 Ramp up Time		
Range:		Function:
Size related*	[ 0.01 - 3600 s]	Enter the ramp-up time, i.e. the acceleration time from 0 RPM to the rated motor speed $n_s$ . Select a ramp-up time such that the output current does not exceed the current limit in <i>parameter 4-18 Current Limit</i> during ramping. The value 0.00 corresponds to 0.01

## Parameter Descriptions

3-71 Ramp 4 Ramp up Time	
Range:	Function:
	s in speed mode. See ramp-down time in <i>parameter 3-72 Ramp 4 Ramp Down Time</i> .
	$Par. 3-71 = \frac{t_{acc} [s] \times n_s [RPM]}{ref [RPM]}$

3-72 Ramp 4 Ramp Down Time	
Range:	Function:
Size related* [0.01 - 3600 s]	Enter the ramp-down time, i.e. the deceleration time from the rated motor speed $n_s$ to 0 RPM. Select a ramp-down time such that no overvoltage arises in the inverter due to regenerative operation of the motor, and such that the generated current does not exceed the current limit set in <i>parameter 4-18 Current Limit</i> . The value 0.00 corresponds to 0.01 s in speed mode. See ramp-up time in <i>parameter 3-71 Ramp 4 Ramp up Time</i> .
	$Par. 3-72 = \frac{t_{dec} [s] \times n_s [RPM]}{ref [RPM]}$

3-80 Jog Ramp Time	
Range:	Function:
Size related* [0.01 - 3600 s]	Enter the jog ramp time, i.e. the acceleration/ deceleration time between 0 RPM and the rated motor frequency $n_s$ . Ensure that the resultant output current required for the given jog ramp time does not exceed the current limit in <i>parameter 4-18 Current Limit</i> . The jog ramp time starts upon activation of a jog signal via the keypad, a selected digital input, or the serial communication port. When jog state is disabled then the normal ramping times are valid.

3-81 Quick Stop Ramp Time	
Range:	Function:
Size related* [0.01 - 3600 s]	Enter the quick-stop ramp-down time, i.e. the deceleration time from the synchronous motor speed to 0 RPM. Ensure that no resultant over-voltage arises in the inverter due to regenerative operation of the motor required to achieve the given ramp-down time. Ensure also that the generated current required to achieve the given ramp-down time does not exceed the current limit (set in <i>parameter 4-18 Current Limit</i> ). Quick-stop is activated by means of a signal on a selected digital input, or via the serial communication port.

6

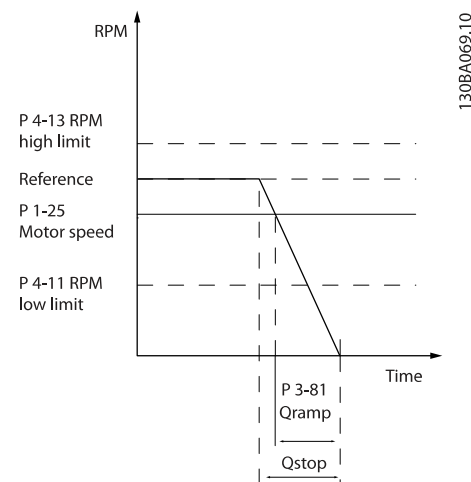

Illustration 6.6 Quick Stop Ramp Time

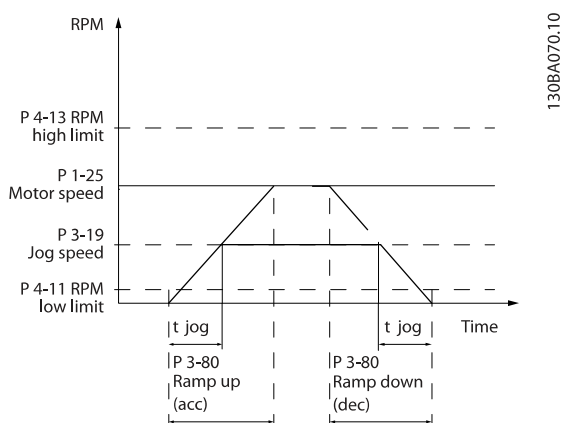

Illustration 6.5 Jog Ramp Time

$$Par. 3-80 = \frac{t_{jog} [s] \times n_s [RPM]}{\Delta \text{ jog speed } (par. 3-19) [RPM]}$$



## 6.5 Parameters: 4-\*\* Limits/Warnings

### 6.5.1 4-1\* Motor Limits

Define torque, current and speed limits for the motor, and the reaction of the frequency converter when the limits are exceeded.

A limit may generate a message on the display. A warning always generates a message in the display or on the fieldbus. A monitoring function may initiate a warning or a trip, upon which the frequency converter stops and generates an alarm message.

4-18 Current Limit		
Range:		Function:
Size related*	[ 1.0 - 1000.0 %]	Enter the current limit for application according to the instruction on the unit. Note, the default value does not start up the compressor but ends in a trip condition A18 Start failed or A49 Speed Limit. A higher value as specified in Table 6.5 violates the UL specification.

Mains voltage	Unit voltage	T/C	Parameter 4-18 Current Limit			
			110%	100%	90%	80%
3 x 200-240V 60 Hz	3 x 208V 60 Hz	TRV200P15T2	68.0 A	61.9 A	55.9 A	49.9 A
		TRV200P18T2	79.9 A	72.8 A	65.7 A	58.7 A
		TRV200P22T2	109.0 A	99.2 A	89.6 A	79.9 A
	3 x 240V 60 Hz	TRV200P15T2	59.0 A	53.8 A	48.7 A	43.6 A
		TRV200P18T2	69.4 A	63.3 A	57.3 A	51.3 A
		TRV200P22T2	94.5 A	86.2 A	78.0 A	69.8 A
3 x 380-480V 60 Hz	3 x 480V 60 Hz	TRV200P15T4	29.4 A	26.8 A	24.2 A	21.6 A
		TRV200P18T4	36.1 A	33.2 A	30.5 A	27.8 A
		TRV200P22T4	48.5 A	44.6 A	40.6 A	37.0 A
3 x 525-600V 60 Hz	3 x 600V 60 Hz	TRV200P18T6	23.6A	21.4A	19.3A	17.1A
		TRV200P22T6	29.1A	26.5A	23.9A	21.2A
		TRV200P30T6	39.2A	35.7A	32.1A	28.6A

Table 6.5 Input Current Limit at Specified Unit Voltage

4-20 Torque Limit Factor Source		
Option:		Function:
		Select an analog input for scaling the settings in 4-16 Torque Limit Motor Mode and 4-17 Torque Limit Generator Mode from 0% to 100% (or inverse). The signal levels corresponding to 0% and 100% are defined in the analog input scaling, e.g. parameter group 6-1* Analog Input 1. This parameter is only active when 1-00 Configuration Mode is in Speed Open Loop or Speed Closed Loop.
[0] *	No function	
[2]	Analog in 53	
[4]	Analog in 53 inv	

4-20 Torque Limit Factor Source		
Option:		Function:
[6]	Analog in 54	
[8]	Analog in 54 inv	
[10]	Analog in X30-11	
[12]	Analog in X30-11 inv	
[14]	Analog in X30-12	
[16]	Analog in X30-12 inv	

## Parameter Descriptions

4-21 Speed Limit Factor SourceOption		
Option:	Function:	
		Select an analog input for scaling the settings in 4-19 <i>Max Output Frequency</i> from 0% to 100% (or vice versa). The signal levels corresponding to 0% and 100% are defined in the analog input scaling, e.g. parameter group 6-7* <i>Analog Input 1</i> . This parameter is only active when 1-00 <i>Configuration Mode</i> is in <i>Torque Mode</i> .
[0] *	No function	
[2]	Analog input 53	
[4]	Analog input 53 inv	
[6]	Analog input 54	
[8]	Analog input 54 inv	
[10]	Analog input X30-11	
[12]	Analog input X30-11 inv	
[14]	Analog input X30-12	
[16]	Analog input X30-12 inv	

### 6.5.2 4-5\* Adjustable Warnings

Use these parameters to adjust warning limits for current, speed, reference and feedback.

Warnings are shown on the keypad, and can be programmed to be outputs or to be read out via serial bus in the Extended Status Word.

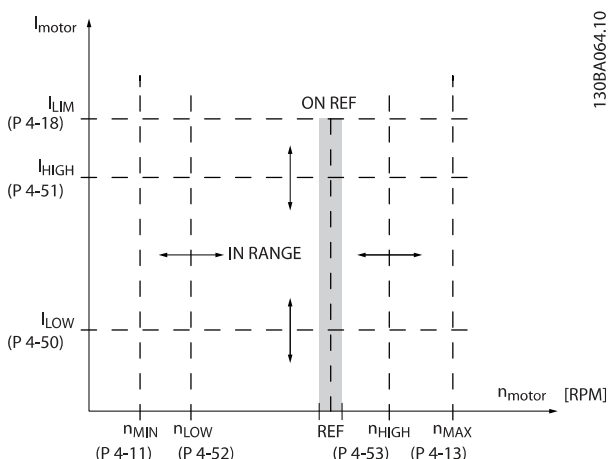

130BA064.10

Illustration 6.7 Adjustable Warnings

4-50 Warning Current Low		
Range:	Function:	
0 A*	[ 0 - par. 4-51 A ]	Enter the $I_{LOW}$ value. When the motor current falls below this limit, the display reads <i>Current</i>

4-50 Warning Current Low		
Range:	Function:	
		<i>Low</i> . The signal outputs can be programmed to produce a status signal on terminal 27 or 29 and on relay output 01 or 02. Refer to <i>Illustration 6.7</i> .

4-51 Warning Current High		
Range:	Function:	
Size related*	[ par. 4-50 - par. 16-37 A ]	Enter the $I_{HIGH}$ value. When the motor current exceeds this limit, the display reads <i>Current High</i> . The signal outputs can be programmed to produce a status signal on terminal 27 or 29 and on relay output 01 or 02.

4-52 Warning Speed Low		
Range:	Function:	
Size related*	[ 0 - par. 4-53 RPM ]	Enter the $n_{LOW}$ value. When the motor speed exceeds this limit, the display reads <i>Speed Low</i> . The signal outputs can be programmed to produce a status signal on terminal 27 or 29 and on relay output 01 or 02.

4-53 Warning Speed High		
Range:	Function:	
Size related*	[ par. 4-52 - 60000 RPM ]	Enter the $n_{HIGH}$ value. When the motor speed exceeds this limit, the display reads <i>Speed High</i> . The signal outputs can be programmed to produce a status signal on terminal 27 or 29 and on relay output 01 or 02. Programme the upper signal limit of the motor speed, $n_{HIGH}$ , within the normal working range of the frequency converter.

4-54 Warning Reference Low		
Range:	Function:	
-999999.999 *	[ -999999.999 - par. 4-55 ]	Enter the lower reference limit. When the actual reference falls below this limit, the display indicates <i>Ref<sub>LOW</sub></i> . The signal outputs can be programmed to produce a status signal on terminal 27 or 29 and on relay output 01 or 02.

4-55 Warning Reference High		
Range:	Function:	
999999.999 *	[ par. 4-54 - 999999.999 ]	Enter the upper reference limit. When the actual reference exceeds this limit, the display reads <i>Ref<sub>HIGH</sub></i> . The signal outputs can be programmed to produce a

## Parameter Descriptions

6

4-55 Warning Reference High		
Range:		Function:
		status signal on terminal 27 or 29 and on relay output 01 or 02.

4-56 Warning Feedback Low		
Range:		Function:
-999999.999 ReferenceFeed- backUnit*	[ -999999.999 - par. 4-57 ReferenceFeed- backUnit]	Enter the lower feedback limit. When the feedback falls below this limit, the display reads Feedb Low. The signal outputs can be programmed to produce a status signal on terminal 27 or 29 and on relay output 01 or 02.

4-57 Warning Feedback High		
Range:		Function:
999999.999 ReferenceFeed- backUnit*	[ par. 4-56 - 999999.999 ReferenceFeed- backUnit]	Enter the upper feedback limit. When the feedback exceeds this limit, the display reads Feedb High. The signal outputs can be programmed to produce a status signal on terminal 27 or 29 and on relay output 01 or 02.

4-58 Missing Motor Phase Function		
Displays alarm 30, 31 or 32 in the event of a missing motor phase. It is strongly recommended to enable to avoid motor damage.		
Option:		Function:
[0]	Off	No alarm is displayed if a missing motor phase occurs.
[1]	On	

### 6.5.3 4-6\* Speed Bypass

Some systems call for avoiding certain output frequencies or speeds, due to resonance problems in the system. A maximum of 4 frequency or speed ranges can be avoided.

4-60 Bypass Speed From [RPM]		
Array [4]		
Range:		Function:
Size related*	[ 0 - par. 4-13 RPM]	Some systems call for avoiding certain output speeds due to resonance problems in the system. Enter the lower limits of the speeds to be avoided.

4-61 Bypass Speed From [Hz]		
Array [4]		
Range:		Function:
Size related*	[ 0 - par. 4-14 Hz]	Some systems call for avoiding certain output speeds due to resonance problems in the system. Enter the lower limits of the speeds to be avoided.

4-62 Bypass Speed To [RPM]		
Array [4]		
Range:		Function:
Size related*	[ 0 - par. 4-13 RPM]	Some systems call for avoiding certain output speeds due to resonance problems in the system. Enter the upper limits of the speeds to be avoided.

4-63 Bypass Speed To [Hz]		
Array [4]		
Range:		Function:
Size related*	[ 0 - par. 4-14 Hz]	Some systems call for avoiding certain output speeds due to resonance problems in the system. Enter the upper limits of the speeds to be avoided.

## Parameter Descriptions

### 6.6 Parameters: 5-\*\* Digital In/Out

#### 6.6.1 5-\*\* Digital In/Out

Parameter group for configuring the digital input and output.

#### 6.6.2 5-0\* Digital In/Out Mode

##### 5-00 Digital In/Out Mode

**Option: Function:**

		Digital inputs and programmed digital outputs are pre-programmable for operation either in PNP or NPN systems.
[0] *	PNP	Action on positive directional pulses.

##### 5-00 Digital In/Out Mode

**Option: Function:**

[1]	NPN	
-----	-----	--

##### 5-01 Terminal 27 Mode

**Option: Function:**

[0] *	Input	Defines terminal 27 as a digital input.
[1]	Output	Defines terminal 27 as a digital output.

### **NOTICE**

This parameter cannot be adjusted while the motor is running.

##### 5-02 Terminal 29 Mode

**Option: Function:**

		Similar to Terminal 27
--	--	------------------------

#### 6.6.3 5-1\* Digital Inputs

Parameters for configuring the input functions for the input terminals.

The digital inputs are used for selecting various functions in the frequency converter. All digital inputs can be set to the following functions:

Digital input function	Select	Terminal
No operation	[0]	All *term 19, 29, 33
Reset	[1]	All *term 32
Coast inverse	[2]	All
Coast and reset inverse	[3]	All
Quick stop inverse	[4]	All
DC-brake inverse	[5]	All
Stop inverse	[6]	All *term 27
Start	[8]	All *term 18
Latched start	[9]	All
Reversing	[10]	All
Start reversing	[11]	All
Enable start forward	[12]	All
Enable start reverse	[13]	All
Jog	[14]	All
Preset reference on	[15]	All
Preset ref bit 0	[16]	All
Preset ref bit 1	[17]	All
Preset ref bit 2	[18]	All
Freeze reference	[19]	All
Freeze output	[20]	All
Speed up	[21]	All
Speed down	[22]	All
Set-up select bit 0	[23]	All
Set-up select bit 1	[24]	All
Catch up	[28]	All
Slow down	[29]	All
Pulse input	[32]	29, 33
Ramp bit 0	[34]	All
Ramp bit 1	[35]	All
Mains failure inverse	[36]	All

## Parameter Descriptions

Digital input function	Select	Terminal
Day/night control	[39]	All
DigiPot Increase	[55]	All
DigiPot Decrease	[56]	All
DigiPot Clear	[57]	All
Counter A (up)	[60]	29, 33
Counter A (down)	[61]	29, 33
Reset Counter A	[62]	All
Counter B (up)	[63]	29, 33
Counter B (down)	[64]	29, 33
Reset Counter B	[65]	All
Lead pump start	[120]	All
Lead pump alternation	[121]	All
Comp. 1 Interlock	[130]	All
Comp. 2 Interlock	[131]	All
Comp. 3 Interlock	[132]	All
Comp. 1 Inv. interlock	[139]	All
Comp. 2 Inv. interlock	[140]	All
Comp. 3 Inv. interlock	[141]	All

**Table 6.6 Overview of Digital Inputs**

Functions dedicated to only one digital input are stated in the associated parameter.

All digital inputs can be programmed to these functions:

[0]	No operation	No reaction to signals transmitted to the terminal.
[1]	Reset	Resets frequency converter after a TRIP/ALARM. Not all alarms can be reset.
[2]	Coast inverse	(Default Digital input 27): Coasting stop, inverted input (NC). The frequency converter leaves the motor in free mode. Logic '0' → coasting stop.
[3]	Coast and reset inverse	Reset and coasting stop Inverted input (NC). Leaves motor in free mode and resets frequency converter. Logic '0' → coasting stop and reset.
[4]	Quick stop inverse	Inverted input (NC). Generates a stop in accordance with quick-stop ramp time set in <i>parameter 3-81 Quick Stop Ramp Time</i> . When motor stops, the shaft is in free mode. Logic '0' → Quick-stop.
[5]	DC-brake inverse	Inverted input for DC braking (NC). Stops motor by energizing it with a DC current for a certain time period. See <i>2-01 DC Brake Current</i> to <i>2-03 DC Brake Cut In Speed [RPM]</i> . The function is only active when the value in <i>2-02 DC Braking Time</i> is different from 0. Logic '0' → DC braking.
[6]	Stop inverse	Stop Inverted function. Generates a stop function when the selected terminal goes from logical level '1' to '0'. The stop is performed according to the selected ramp time ( <i>3-42 Ramp 1 Ramp Down Time, 3-52 Ramp 2</i>

		<i>Ramp Down Time, 3-62 Ramp 3 Ramp down Time, 3-72 Ramp 4 Ramp Down Time</i> . <b>NOTICE</b> When the frequency converter is at the torque limit and has received a stop command, it may not stop by itself. To ensure that the frequency converter stops, configure a digital output to [27] <i>Torque limit &amp; stop</i> and connect this digital output to a digital input that is configured as coast.
[8]	Start	(Default Digital input 18): Select start for a start/stop command. Logic '1' = start, logic '0' = stop.
[9]	Latched start	The motor starts, if a pulse is applied for min. 2 ms. The motor stops when Stop inverse is activated.
[10]	Reversing	(Default Digital input 19). Change the direction of motor shaft rotation. Select Logic '1' to reverse. The reversing signal only changes the direction of rotation. It does not activate the start function. Select both directions in <i>4-10 Motor Speed Direction</i> . The function is not active in process closed loop.
[11]	Start reversing	Used for start/stop and for reversing on the same wire. Signals on start are not allowed at the same time.
[12]	Enable start forward	Rotates motor shaft clockwise at start.
[13]	Enable start reverse	Rotates motor shaft counterclockwise at start.

## Parameter Descriptions

[14]	Jog	(Default Digital input 29): Use to activate jog speed. See 3-11 <i>Jog Speed [Hz]</i> .
[15]	Preset reference on	Shifts between external reference and preset reference. It is assumed that [1] <i>External/preset</i> has been selected in 3-04 <i>Reference Function</i> . Logic '0' = external reference active; logic '1' = one of the eight preset references is active.
[16]	Preset ref bit 0	Preset ref. bit 0,1, and 2 enables a choice between one of the eight preset references according to Table 6.7.
[17]	Preset ref bit 1	Same as Preset ref bit 0 [16].
[18]	Preset ref bit 2	Same as Preset ref bit 0 [16].

Preset ref. bit	2	1	0
Preset ref. 0	0	0	0
Preset ref. 1	0	0	1
Preset ref. 2	0	1	0
Preset ref. 3	0	1	1
Preset ref. 4	1	0	0
Preset ref. 5	1	0	1
Preset ref. 6	1	1	0
Preset ref. 7	1	1	1

Table 6.7 Reference Bits

[19]	Freeze ref	Freezes the actual reference, which is now the point of enable/condition for Speed up and Speed down to be used. If Speed up/down is used, the speed change always follows ramp 2 (3-51 <i>Ramp 2 Ramp Up Time</i> and 3-52 <i>Ramp 2 Ramp Down Time</i> ) in the range 0 - 3-03 <i>Maximum Reference</i> .
[20]	Freeze output	Freezes the actual motor frequency (Hz), which is now the point of enable/condition for Speed up and Speed down to be used. If Speed up/down is used, the speed change always follows ramp 2 (3-51 <i>Ramp 2 Ramp Up Time</i> and 3-52 <i>Ramp 2 Ramp Down Time</i> ) in the range 0 to 1-23 <i>Motor Frequency</i> . <b>NOTICE</b> When Freeze output is active, the frequency converter cannot be stopped via a low [8] <i>start</i> signal. Stop the frequency converter via a terminal programmed for [2] <i>Coasting inverse</i> or [3] <i>Coast and reset, inverse</i> .
[21]	Speed up	Select Speed up and Speed down if digital control of the up/down speed is desired (motor potentiometer). Activate this function by selecting either Freeze reference or Freeze output. When Speed up/ down is activated for less than 400 ms the resulting reference will be increased/ decreased by 0.1 %. If Speed up/ down is activated for more than 400 ms the resulting reference will follow the setting in ramping up/ down parameter 3-x1/ 3-x2.

	Shut down	Catch up
Unchanged speed	0	0
Reduced by %-value	1	0
Increased by %-value	0	1
Reduced by %-value	1	1

Table 6.8 Digital Speed Control

[22]	Speed down	Same as Speed up [21].
[23]	Set-up select bit 0	Select Set-up select bit 0 or Select Set-up select bit 1 to select one of the 4 set-ups. Set 0-10 <i>Active Set-up</i> to Multi Set-up.
[24]	Set-up select bit 1	(Default Digital input 32): Same as [23] <i>Set-up select bit 0</i> .
[28]	Catch up	Increases or reduces reference value set in 3-12 <i>Catch up/slow Down Value</i> .
[29]	Slow down	[28] <i>Same as Catch up</i> .
[30]	Counter input	Precise stop function in 1-83 <i>Precise Stop Function</i> acts as Counter stop or speed compensated counter stop with or without reset. The counter value must be set in 1-84 <i>Precise Stop Counter Value</i> .
[32]	Pulse input	Use pulse sequence as either reference or feedback. Scaling is done in parameter group 5-5* <i>Pulse Input</i> .
[34]	Ramp bit 0	Enables a choice between one of the 4 ramps available, according to Table 6.9.
[35]	Ramp bit 1	Same as [34] <i>Ramp bit 0</i> .

Preset ramp bit	1	0
Ramp 1	0	0
Ramp 2	0	1
Ramp 3	1	0
Ramp 4	1	1

Table 6.9 Ramp Bits

[36]	Mains failure inverse	Activates 14-10 <i>Mains Failure</i> . Mains failure inverse is active in the Logic .0. situation.
[39]	Day/Night Control	Reduce the max. frequency with the setting in 28-74 <i>Night Speed Drop [RPM]</i> .
[41]	Latched Precise Stop inverse	Sends a latched stop signal when the precise stop function is activated in 1-83 <i>Precise Stop Function</i> . The Latched Precise stop inverse function is available for terminals 18 or 19.
[55]	DigiPot Increase	INCREASE signal to the Digital Potentiometer function described in parameter group 3-9* <i>Digital Potmeter</i> .
[56]	DigiPot Decrease	DECREASE signal to the Digital Potentiometer function described in parameter group 3-9* <i>Digital Potmeter</i> .
[57]	DigiPot Clear	Clears the Digital Potentiometer reference described in parameter group 3-9* <i>Digital Potmeter</i> .

## Parameter Descriptions

6

[60]	Counter A	(Terminal 29 or 33 only) Input for increment counting in the SLC counter.
[61]	Counter A	(Terminal 29 or 33 only) Input for decrement counting in the SLC counter.
[62]	Reset Counter A	Input for reset of counter A.
[63]	Counter B	(Terminal 29 or 33 only) Input for increment counting in the SLC counter.
[64]	Counter B	(Terminal 29 or 33 only) Input for decrement counting in the SLC counter.
[65]	Reset Counter B	Input for reset of counter B.
[70]	Mech. Brake Feedback	Brake feedback for hoisting applications
[71]	Mech. Brake Feedback inv.	Inverted brake feedback for hoisting applications
[80]	PTC Card 1	All Digital Inputs can be set to [80] PTC Card 1. However, only one Digital Input must be set to this choice.
[121]	Lead Pump Alternation	
[130]	Compressor Interlock	Use with cascade controller. Logic 1 will stop the fixed speed compressor and give a warning
[131]	Compressor Interlock	Use with cascade controller. Logic 1 will stop the fixed speed compressor and give a warning
[132]	Compressor Interlock	Use with cascade controller. Logic 1 will stop the fixed speed compressor and give a warning

### 5-10 Terminal 18 Digital Input

**Option:**      **Function:**

[8] *	Start	Functions are described under parameter group 5-1* <i>Digital Inputs</i>
-------	-------	--

### 5-11 Terminal 19 Digital Input

**Option:**      **Function:**

[10] *	Reversing	Functions are described under parameter group 5-1* <i>Digital Inputs</i>
--------	-----------	--

### 5-12 Terminal 27 Digital Input

**Option:**      **Function:**

[0] *	No operation	
[1]	Reset	
[2]	Coast inverse	Functions are described under parameter group 5-1* <i>Digital Inputs</i>
[3]	Coast and reset inv	
[4]	Quick stop inverse	
[5]	DC-brake inverse	
[6]	Stop inverse	
[8]	Start	
[9]	Latched start	
[10]	Reversing	
[11]	Start reversing	
[12]	Enable start forward	
[13]	Enable start reverse	

### 5-12 Terminal 27 Digital Input

**Option:**      **Function:**

[14]	Jog	
[15]	Preset reference on	
[16]	Preset ref bit 0	
[17]	Preset ref bit 1	
[18]	Preset ref bit 2	
[19]	Freeze reference	
[20]	Freeze output	
[21]	Speed up	
[22]	Speed down	
[23]	Set-up select bit 0	
[24]	Set-up select bit 1	
[28]	Catch up	
[29]	Slow down	
[34]	Ramp bit 0	
[35]	Ramp bit 1	
[36]	Mains failure inverse	
[39]	Day/Night Control	
[50]	ATEX thermistor monitor	
[55]	DigiPot increase	
[56]	DigiPot decrease	
[57]	DigiPot clear	
[58]	DigiPot Hoist	
[62]	Reset Counter A	
[65]	Reset Counter B	
[70]	Mech. Brake Feedb.	
[71]	Mech. Brake Feedb. Inv.	
[120]	Lead Comp. Start	
[121]	Lead Comp. Alternation	
[130]	Comp. 1 Interlock	
[131]	Comp. 2 Interlock	
[132]	Comp. 3 Interlock	
[139]	Comp. 1 Inv. Interlock	
[140]	Comp. 2 Inv. Interlock	
[141]	Comp. 3 Inv. Interlock	

### 5-13 Terminal 29 Digital Input

**Option:**      **Function:**

		Select the function from the available digital input range and the additional options [60], [61], [63] and [64]. Counters are used in Smart Logic Control functions.
[14] *	Jog	
[60]	Counter A (up)	
[61]	Counter A (down)	
[63]	Counter B (up)	
[64]	Counter B (down)	

### 5-14 Terminal 32 Digital Input

**Option:**      **Function:**

		Select the function from the available digital input range.
	Reset	Functions are described under 5-1* <i>Digital Inputs</i>

## Parameter Descriptions

5-15 Terminal 33 Digital Input		
Option:	Function:	
		Select the function from the available digital input range and the additional options [60], [61], [63] and [64]. Counters are used in Smart Logic Control functions.
[0] *	No operation	Functions are described under 5-1* <i>Digital Inputs</i>

5-19 Terminal 37 Safe Stop		
Option:	Function:	
[1]	Safe Stop Alarm	
[3] *	Safe Stop Warning	
[4]	PTC 1 Alarm	
[5]	PTC 1 Warning	
[6]	PTC 1 & Relay A	
[7]	PTC 1 & Relay W	
[8]	PTC 1 & Relay A/W	
[9]	PTC 1 & Relay W/A	

### 6.6.4 5-3\* Digital Outputs

Parameters for configuring the output functions for the output terminals. The 2 solid-state digital outputs are common for terminals 27 and 29. Set the I/O function for terminal 27 in 5-01 *Terminal 27 Mode*, and set the I/O function for terminal 29 in 5-02 *Terminal 29 Mode*. Digital outputs appear if 5-01 *Terminal 27 Mode* or 5-02 *Terminal 29 Mode* are set to output.

#### **NOTICE**

These parameters cannot be adjusted while the motor is running.

#### **NOTICE**

Only for activating 24 V DC devices – restricted use for relays.

		The digital outputs can be programmed with these functions:
[0]	No operation	<i>Default for all digital outputs and relay outputs</i>
[1]	Control ready	The control board receives supply voltage.
[2]	Drive ready	The frequency converter is ready for operation and applies a supply signal on the control board.
[3]	Drive ready / remote control	The frequency converter is ready for operation and is in Auto On mode.
[4]	Stand-by / no warning	The frequency converter is ready for operation. No start or stop command is been given (start/disable). There are no warnings.
[5]	Running	The motor is running.

[6]	Running / no warning	The output speed is higher than the speed set in 1-81 <i>Min Speed for Function at Stop [RPM]</i> . The motor is running and there are no warnings.
[7]	Run on reference / no warning	The motor runs at reference speed.
[8]	Run in range / no warning	The motor runs in speed range.
[9]	Alarm	An alarm activates the output. There are no warnings.
[10]	Alarm or warning	An alarm or a warning activates the output.
[11]	At torque limit	The torque limit set in 4-16 <i>Torque Limit Motor Mode</i> or 1-17 <i>Voltage filter time const.</i> has been exceeded.
[12]	Out of current range	The motor current is outside the range set in 4-18 <i>Current Limit</i> .
[13]	Below current, low	The motor current is lower than set in <i>parameter 4-50 Warning Current Low</i> .
[14]	Above current, high	The motor current is higher than set in <i>parameter 4-51 Warning Current High</i> .
[15]	Out of speed range	The output speed is outside the range set in <i>parameter 4-52 Warning Speed Low</i> and 4-53 <i>Warning Speed High</i> .
[16]	Below speed, low	The output speed is lower than the setting in <i>parameter 4-52 Warning Speed Low</i> .
[17]	Above speed, high	The output speed is higher than the setting in 4-53 <i>Warning Speed High</i> .
[18]	Out of feedback	The feedback is outside the range set in <i>parameter 4-56 Warning Feedback Low</i> and <i>parameter 4-57 Warning Feedback High</i> .
[19]	Below feedback low	The feedback is below the limit set in <i>parameter 4-56 Warning Feedback Low</i> .
[20]	Above feedback high	The feedback is above the limit set in <i>parameter 4-57 Warning Feedback High</i> .
[21]	Thermal warning	The thermal warning turns on when the temperature exceeds the limit in the motor, the frequency converter, the brake resistor, or the thermistor.
[25]	Reverse	<i>Reversing. Logic '1' = relay activated, 24 V DC when CW rotation of the motor. Logic '0' = relay not activated, no signal, when CCW rotation of the motor.</i>
[26]	Bus OK	Active communication (no time-out) via the serial communication port.
[27]	Torque limit and stop	Use in performing a coasting stop and in torque limit condition. If the frequency converter has received a stop signal and is at the torque limit, the signal is Logic '0'.
[28]	Brake, no warning	The brake is active and there are no warnings.
[29]	Brake ready, no fault	The brake is ready for operation and there are no faults.



## Parameter Descriptions

6

[30]	Brake fault (IGBT)	The output is Logic '1' when the brake IGBT is short-circuited. Use this function to protect the frequency converter if there is a fault on the brake modules. Use the output/relay to cut out the main voltage from the frequency converter.
[33]	Safe Stop Active	Indicates that the safe stop on terminal 37 is active.
[35]	External Interlock	External Interlock function has been activated via one of the digital inputs.
[40]	Out of ref range	Active when the actual speed is outside the settings in 4-52 <i>Warning Speed Low</i> to 4-55 <i>Warning Reference High</i> .
[41]	Below reference low	Active when the actual speed is below the speed reference setting.
[42]	Above reference high	Active when the actual speed is above the speed reference setting.
[45]	Bus Ctrl	Control output via bus. The state of the output is set in <i>parameter 5-90 Digital &amp; Relay Bus Control</i> . The output state is retained in the event of bus time-out.
[46]	Bus Ctrl 1 if timeout	Controls output via bus. The state of the output is set in <i>parameter 5-90 Digital &amp; Relay Bus Control</i> . In the event of bus time-out the output state is set low (On).
[47]	Bus Ctrl 0 if timeout	Controls output via bus. The state of the output is set in <i>parameter 5-90 Digital &amp; Relay Bus Control</i> . In the event of bus time-out the output state is set low (Off).
[55]	Pulse output	
[60]	Comparator 0	See parameter group 13-1* <i>Comparators</i> . If Comparator 0 is evaluated as TRUE, the output will go high. Otherwise, it will be low.
[61]	Comparator 1	See parameter group 13-1* <i>Comparators</i> . If Comparator 2 is evaluated as TRUE, the output will go high. Otherwise, it will be low.
[62]	Comparator 2	See parameter group 13-1* <i>Comparators</i> . If Comparator 2 is evaluated as TRUE, the output will go high. Otherwise, it will be low.
[63]	Comparator 3	See parameter group 13-1* <i>Comparators</i> . If Comparator 3 is evaluated as TRUE, the output will go high. Otherwise, it will be low.
[64]	Comparator 4	See parameter group 13-1* <i>Comparators</i> . If Comparator 4 is evaluated as TRUE, the output will go high. Otherwise, it will be low.
[65]	Comparator 5	See parameter group 13-1* <i>Comparators</i> . If Comparator 4 is evaluated as TRUE, the output will go high. Otherwise, it will be low.
[70]	Logic Rule 0	See parameter group 13-4* <i>Logic Rules</i> . If Logic Rule 0 is evaluated as TRUE, the

		output will go high. Otherwise, it will be low.
[71]	Logic Rule 1	See parameter group 13-4* <i>Logic Rules</i> . If Logic Rule 1 is evaluated as TRUE, the output will go high. Otherwise, it will be low.
[72]	Logic Rule 2	See parameter group 13-4* <i>Logic Rules</i> . If Logic Rule 2 is evaluated as TRUE, the output will go high. Otherwise, it will be low.
[73]	Logic Rule 3	See parameter group 13-4* <i>Logic Rules</i> . If Logic Rule 3 is evaluated as TRUE, the output will go high. Otherwise, it will be low.
[74]	Logic Rule 4	See parameter group 13-4* <i>Logic Rules</i> . If Logic Rule 4 is evaluated as TRUE, the output will go high. Otherwise, it will be low.
[75]	Logic Rule 5	See parameter group 13-4* <i>Logic Rules</i> . If Logic Rule 5 is evaluated as TRUE, the output will go high. Otherwise, it will be low.
[80]	SL Digital Output A	See 13-52 <i>SL Controller Action</i> . The input will go high whenever the Smart Logic Action [38] <i>Set dig. out. A high</i> is executed. The input will go low whenever the Smart Logic Action [32] <i>Set dig. out. A low</i> is executed.
[81]	SL Digital Output B	See 13-52 <i>SL Controller Action</i> . The input will go high whenever the Smart Logic Action [39] <i>Set dig. out. A high</i> is executed. The input will go low whenever the Smart Logic Action [33] <i>Set dig. out. A low</i> is executed.
[82]	SL Digital Output C	See 13-52 <i>SL Controller Action</i> . The input will go high whenever the Smart Logic Action [40] <i>Set dig. out. A high</i> is executed. The input will go low whenever the Smart Logic Action [34] <i>Set dig. out. A low</i> is executed.
[83]	SL Digital Output D	See 13-52 <i>SL Controller Action</i> . The input will go high whenever the Smart Logic Action [41] <i>Set dig. out. A high</i> is executed. The input will go low whenever the Smart Logic Action [35] <i>Set dig. out. A low</i> is executed.
[84]	SL Digital Output E	See 13-52 <i>SL Controller Action</i> . The input will go high whenever the Smart Logic Action [42] <i>Set dig. out. A high</i> is executed. The input will go low whenever the Smart Logic Action [36] <i>Set dig. out. A low</i> is executed.
[85]	SL Digital Output F	See 13-52 <i>SL Controller Action</i> . The input will go high whenever the Smart Logic Action [43] <i>Set dig. out. A high</i> is executed. The input will go low whenever the Smart

## Parameter Descriptions

		Logic Action [37] Set dig. out. A low is executed.
[122]	No alarm	The output is high when no alarm is present.
[123]	Start command active	The output is high when there is an active Start command (i.e. via digital input bus connection or [Hand on] or [Auto on], and no Stop or Start command is active.
[124]	Running reverse	The output is high when the frequency converter is running counter clockwise (the logical product of the status bits 'running' AND 'reverse').
[125]	Drive in hand mode	The output is high when the frequency converter is in Hand on mode (as indicated by the LED light above [Hand on]).
[126]	Drive in auto mode	The output is high when the frequency converter is in Hand on mode (as indicated by the LED light above [Auto on]).
[139]	Compressor Inv. Interlock	Use with cascade controller. Logic will stop the fixed speed compressor and give a warning.
[140]	Compressor Inv. Interlock	Use with cascade controller. Logic will stop the fixed speed compressor and give a warning.
[141]	Compressor Inv. Interlock	Use with cascade controller. Logic will stop the fixed speed compressor and give a warning.
[195]	Bypass Valve Control	<p>The bypass valve control (Digital/Relay output in the frequency converter) is used for compressor systems to unload the compressor during start-up by using a bypass valve. After the start command is given the bypass valve will be open until the frequency converter reaches 4-11 Motor Speed Low Limit [RPM]). After the limit has been reached the bypass valve will be closed, allowing the compressor to operate normally. This procedure will not be activated again before a new start is initiated and the frequency converter speed is zero during the receiving of start signal. 1-71 Start Delay can be used in order to delay the motor start. The bypass valve control principle:</p> <p style="text-align: right;">130BA251.10</p>

Illustration 6.8 Bypass Valve Control

The below setting options are all related to the Cascade Controller.

Wiring diagrams and settings for parameter, see parameter group 25-\*\* Cascade Pack Controller or more details.

### 6.6.5 5-4\* Relays (Dry Contacts)

#### NOTICE

Relays 7, 8, and 9 are only available if MCB 105 relay card is installed.

#### NOTICE

Relay 1 is dedicated to controlling the solenoid valve.

Parameters for configuring the timing and the output functions for the relays.

#### 5-40 Function Relay

Array [8] (Relay 1 [0], Relay 2 [1], Relay 7 [6], Relay 8 [7], Relay 9 [8])

[0]	No Operation
[1]	Control Ready
[2]	Drive Ready
[3]	Drive Ready/Remote
[4]	Stand-by/No Warning
[5] *	Running
[6]	Running/No Warning
[8]	Run on Ref./No Warning
[9]	Alarm
[10]	Alarm or Warning
[11]	At Torque Limit
[12]	Out of Current Range
[13]	Below Current, low
[14]	Above Current, high
[15]	Out of Speed Range
[16]	Below Speed, low
[17]	Above Speed, high
[18]	Out of Feedb. Range
[19]	Below Feedback, low
[20]	Above Feedback, high
[21]	Thermal Warning
[22]	Ready, no thermal w
[25]	Reverse
[26]	Bus OK
[27]	Torque Limit & Stop
[28]	Brake, No Warning
[29]	Brake Ready, No Fault
[30]	Brake Fault (IGBT)
[31]	Relay 123
[32]	Mech brake ctrl
[33]	Safe stop active
[35]	External Interlock
[36]	Control Word Bit 11

## Parameter Descriptions

6

[37]	Control Word Bit 12	
[40]	Out of Ref. Range	
[41]	Below Reference, low	
[42]	Above Ref. high	
[45]	Bus ctrl	
[46]	Bus ctrl, 1 if timeout	
[47]	Bus ctrl, 0 if timeout	
[60]	Comparator 0	
[61]	Comparator 1	
[62]	Comparator 2	
[63]	Comparator 3	
[64]	Comparator 4	
[65]	Comparator 5	
[70]	Logic Rule 0	
[71]	Logic Rule 1	
[72]	Logic Rule 2	
[73]	Logic Rule 3	
[74]	Logic Rule 4	
[75]	Logic Rule 5	
[80]	SL Digital Output A	
[81]	SL Digital Output B	
[82]	SL Digital Output C	
[83]	SL Digital Output D	
[84]	SL Digital Output E	
[85]	SL Digital Output F	
[120]	Local Ref. Active	
[121]	Remote Ref. Active	
[122]	No Alarm	
[123]	Start Cmd. Active	
[124]	Running Reverse	
[125]	Drive in Hand Mode	
[126]	Drive in Auto Mode	
[195]	Bypass Valve Control	
[211]	Cascade Compressor 1	
[212]	Cascade Compressor 2	
[213]	Cascade Compressor 3	

5-50 Term. 29 Low Frequency		
Range:	Function:	
100 Hz* [0 - 110000 Hz]	Enter the low frequency limit corresponding to the low motor shaft speed (i.e. low reference value) in 5-52 Term. 29 Low Ref./Feedb. Value. Refer to the diagram in this section.	

5-51 Term. 29 High Frequency		
Range:	Function:	
100 Hz* [0 - 110000 Hz]	Enter the high frequency limit corresponding to the high motor shaft speed (i.e. high reference value) in 5-53 Term. 29 High Ref./Feedb. Value.	

5-52 Term. 29 Low Ref./Feedb. Value		
Range:	Function:	
0 ReferenceFeed-backUnit* [-999999.999 - 999999.999 ReferenceFeed-backUnit]	Enter the low reference value limit for the motor shaft speed [RPM]. This is also the lowest feedback value, see also parameter 5-57 Term. 33 Low Ref./Feedb. Value. Set terminal 29 to digital input (5-02 Terminal 29 Mode = [0] input (default) and 5-13 Terminal 29 Digital Input = applicable value).	

5-53 Term. 29 High Ref./Feedb. Value		
Range:	Function:	
Size related* [-999999.999 - 999999.999 ReferenceFeed-backUnit]	Enter the high reference value [RPM] for the motor shaft speed and the high feedback value, see also parameter 5-58 Term. 33 High Ref./Feedb. Value. Select terminal 29 as a digital input (5-02 Terminal 29 Mode = [0] input (default) and 5-13 Terminal 29 Digital Input = applicable value).	

5-54 Pulse Filter Time Constant #29		
Range:	Function:	
100 ms* [1 - 1000 ms]	Enter the pulse filter time constant. The pulse filter dampens oscillations of the feedback signal, which is an advantage if there is a lot of noise in the system. A high time constant value results in better dampening but also increases the time delay through the filter.	

5-55 Term. 33 Low Frequency		
Range:	Function:	
100 Hz* [0 - 110000 Hz]	Enter the low frequency corresponding to the low motor shaft speed (i.e. low reference value) in parameter 5-57 Term. 33 Low Ref./Feedb. Value.	

5-56 Term. 33 High Frequency		
Range:	Function:	
100 Hz* [0 - 110000 Hz]	Enter the high frequency corresponding to the high motor shaft speed (i.e. high reference value) in 5-58 Term. 33 High Ref./Feedb. Value.	

## Parameter Descriptions

5-57 Term. 33 Low Ref./Feedb. Value		
Range:		Function:
0*	[-999999.999 - 999999.999 ]	Enter the low reference value [RPM] for the motor shaft speed. This is also the low feedback value, see also 5-52 Term. 29 Low Ref./Feedb. Value.

5-58 Term. 33 High Ref./Feedb. Value		
Range:		Function:
Size related*	[-999999.999 - 999999.999 ReferenceFeed-backUnit]	Enter the high reference value [RPM] for the motor shaft speed. See also 5-53 Term. 29 High Ref./Feedb. Value.

5-59 Pulse Filter Time Constant #33		
Range:		Function:
100 ms*	[1 - 1000 ms]	Enter the pulse filter time constant. The low-pass filter reduces the influence on and dampens oscillations on the feedback signal from the control. This is an advantage, e.g. if there is a great amount on noise in the system.

5-60 Terminal 27 Pulse Output Variable		
Option:		Function:
[0]	No operation	Select the desired display output for terminal 27.
[45]	Bus ctrl.	
[48]	Bus ctrl., timeout	
[51]	MCO controlled	
[100]	Output frequency	
[101]	Reference	
[102]	Feedback	
[103]	Motor Current	
[104]	Torque rel to limit	
[105]	Torq relate to rated	
[106]	Power	
[107]	Speed	
[108]	Torque	
[109]	Max Out Freq	
[119]	Torque % lim	

5-62 Pulse Output Max Freq #27		
Range:		Function:
Size related*	[0 - 32000 Hz]	Set the maximum frequency for terminal 27, corresponding to the output variable selected in parameter 5-60 Terminal 27 Pulse Output Variable.

5-63 Terminal 29 Pulse Output Variable		
Option:		Function:
[0]	No operation	Select the desired display output for terminal 29.
[45]	Bus ctrl.	
[48]	Bus ctrl., timeout	
[51]	MCO controlled	
[100]	Output frequency	
[101]	Reference	
[102]	Feedback	
[103]	Motor Current	
[104]	Torque rel to limit	
[105]	Torq relate to rated	
[106]	Power	
[107]	Speed	
[108]	Torque	
[109]	Max Out Freq	

5-65 Pulse Output Max Freq #29		
Range:		Function:
5000 Hz*	[0 - 32000 Hz]	Set the maximum frequency for terminal 29 corresponding to the output variable set in 5-63 Terminal 29 Pulse Output Variable.

5-90 Digital & Relay Bus Control		
Range:		Function:
0*	[0 - 2147483647 ]	This parameter holds the state of the digital outputs and relays that is controlled by bus. A logical '1' indicates that the output is high or active. A logical '0' indicates that the output is low or inactive.

## Parameter Descriptions

Bit 0	Digital Output Terminal 27
Bit 1	Digital Output Terminal 29
Bit 2	Digital Output Terminal X 30/6
Bit 3	Digital Output Terminal X 30/7
Bit 4	Relay 1 output terminal
Bit 5	Relay 2 output terminal
Bit 6	Option B Relay 1 output terminal
Bit 7	Option B Relay 2 output terminal
Bit 8	Option B Relay 3 output terminal
Bit 9-15	Reserved for future terminals
Bit 16	Option C Relay 1 output terminal
Bit 17	Option C Relay 2 output terminal
Bit 18	Option C Relay 3 output terminal
Bit 19	Option C Relay 4 output terminal
Bit 20	Option C Relay 5 output terminal
Bit 21	Option C Relay 6 output terminal
Bit 22	Option C Relay 7 output terminal
Bit 23	Option C Relay 8 output terminal
Bit 24-31	Reserved for future terminals

**Table 6.10 Bus-controlled Digital Outputs and Relays**

5-93 Pulse Out #27 Bus Control		
Range:	Function:	
0 %* [0 - 100 %]	Set the output frequency transferred to the output terminal 27 when the terminal is configured as [45] Bus Controlled in parameter 5-60 Terminal 27 Pulse Output Variable.	

5-95 Pulse Out #29 Bus Control		
Range:	Function:	
0 %* [0 - 100 %]	Set the output frequency transferred to the output terminal 29 when the terminal is configured as [45] Bus Controlled in 5-63 Terminal 29 Pulse Output Variable.	

## Parameter Descriptions

### 6.7 Parameters: 6-\*\* Analog In/Out

Parameter group for configuration of the analog input and output.

#### 6.7.1 6-0\* Analog In/Out Mode

Parameter group for setting up the analog In/Out configuration.

The frequency converter is equipped with 2 analog inputs: Terminal 53 and 54. The analog inputs on the frequency converter can freely be allocated to either voltage (-10 V to +10 V) or current input (0/4 to 20 mA).

6-00 Live Zero Timeout Time		
Range:	Function:	
10 s* [1 - 99 s]	Enter the Live Zero Time-out time period. Live Zero Time-out Time is active for analog inputs, i.e. terminal 53 or terminal 54, used as reference or feedback sources. If the reference signal value associated with the selected current input falls below 50% of the value set in 6-10 Terminal 53 Low Voltage, 6-12 Terminal 53 Low Current, 6-20 Terminal 54 Low Voltage or 6-22 Terminal 54 Low Current for a time period longer than the time set in parameter 6-00 Live Zero Timeout Time, the function selected in 6-01 Live Zero Timeout Function is activated.	

6-01 Live Zero Timeout Function		
Option:	Function:	
	Select the time-out function. The function set in 6-01 Live Zero Timeout Function will be activated if the input signal on terminal 53 or 54 is below 50% of the value in 6-10 Terminal 53 Low Voltage, 6-12 Terminal 53 Low Current, 6-20 Terminal 54 Low Voltage or 6-22 Terminal 54 Low Current for a time period defined in parameter 6-00 Live Zero Timeout Time. If several time-outs occur simultaneously, the frequency converter prioritises the time-out functions as follows: <ol style="list-style-type: none"> <li>6-01 Live Zero Timeout Function</li> <li>Parameter 8-04 Control Word Timeout Function</li> </ol>	
[1]	Freeze Output	Frozen at the present value
[0] *	Off	
[1]	Freeze output	Frozen at the present value
[2]	Stop	Overruled to stop
[3]	Jogging	Overruled to jog speed
[4]	Max. speed	Overruled to max. speed

6-01 Live Zero Timeout Function		
Option:	Function:	
[5]	Stop and trip	Overruled to stop with subsequent trip

#### 6.7.2 6-1\* Analog Input 1

Parameters for configuring the scaling and limits for analog input 1 (terminal 53).

### NOTICE

Analog input 53 is preset for usage with "open loop" control on 0-10 V. Terminal 54 is preset for "Process Loop" control using a pressure sensor AKS with a pressure range of -1 : 12 bar.

6-10 Terminal 53 Low Voltage		
Range:	Function:	
0.00V* [-10.0 - 6-11]	This analog input scaling value should correspond to the minimum reference value, set in 3-02 Minimum Reference.	

6-11 Terminal 53 High Voltage		
Range:	Function:	
Hardware dependent*	[6-10 to 10 V]	This analog input scaling value should correspond to the maximum reference value, set in 3-03 Maximum Reference.

6-12 Terminal 53 Low Current		
Range:	Function:	
4.0mA* [0.0 to par. 6-13 mA]	This reference signal should correspond to the minimum reference value, set in 3-02 Minimum Reference.	

6-13 Terminal 53 High Current		
Range:	Function:	
20.0mA* [6-12 to 20 mA]	This reference signal should correspond to the maximum reference value, set in 3-02 Minimum Reference.	

6-14 Terminal 53 Low Ref./Feedb. Value		
Range:	Function:	
Size related*	[Enter the analog input scaling value that corresponds to the low voltage/low current set in 6-10 Terminal 53 Low Voltage and 6-12 Terminal 53 Low Current.]	

## Parameter Descriptions

6

6-15 Terminal 53 High Ref./Feedb. Value		
Range:	Function:	
Size related* <input type="checkbox"/>		
	Enter the analog input scaling value that corresponds to the maximum reference feedback value set in <i>6-11 Terminal 53 High Voltage</i> and <i>6-13 Terminal 53 High Current</i> .	

6-16 Terminal 53 Filter Time Constant		
Range:	Function:	
0.001 s* [0.001 - 10 s]	<b>NOTICE</b>	
	<p><b>This parameter cannot be adjusted while the motor is running.</b></p> <p>Enter the time constant. This is a first-order digital low pass filter time constant for suppressing electrical noise in terminal 53. A high time constant value improves dampening, but also increases the time delay through the filter.</p>	

### 6.7.3 6-2\* Analog Input 2

Parameters for configuring the scaling and limits for analog input 2 (terminal 54).

#### **NOTICE**

Analog input 53 is preset for usage with "open loop" control on 0-10 V. Terminal 54 is preset for "Process Loop" control using a pressure sensor AKS with a pressure range of -1 : 12 bar.

6-20 Terminal 54 Low Voltage		
Range:	Function:	
1.00V* [-10.0 - par. 6-11]	This analog input scaling value should correspond to the minimum output value of the pressure sensor	

6-21 Terminal 54 High Voltage		
Range:	Function:	
5.00V* [6-10 to 10 V]	This analog input scaling value should correspond to the maximum output value of the pressure sensor.	

6-22 Terminal 54 Low Current		
Range:	Function:	
4.0mA * [0.0 to par. 6-13 mA]	This reference signal should correspond to the minimum output value of the pressure sensor.	

6-23 Terminal 54 High Current		
Range:	Function:	
20.0mA * [6-12 to 20 mA]	This reference signal should correspond to the maximum output value of the pressure sensor.	

6-24 Terminal 54 Low Ref./Feedb.		
Range:	Function:	
-1 (bar) [Value]	Enter the analog input scaling value that corresponds to the minimum reference feedback value set in <i>3-02 Minimum Reference</i> .	

6-25 Terminal 54 High Ref./Feedb.		
Range:	Function:	
12 (bar) [Value ]	Enter the analog input scaling value that corresponds to the maximum reference feedback value set in <i>3-03 Maximum Reference</i> .	

6-26 Terminal 54 Filter Time Constant		
Range:	Function:	
0.001 s* [0.001 - 10 s]	<b>NOTICE</b>	
	<p><b>This parameter cannot be adjusted while the motor is running.</b></p> <p>Enter the time constant. This is a first-order digital low pass filter time constant for suppressing electrical noise in terminal 54. A high time constant value improves dampening but also increases the time delay through the filter.</p>	

6-50 Terminal 42 Output		
Option:	Function:	
		Select the function of Terminal 42 as an analog current output. Depending on the selection the output is either a 0-20 mA or 4-20 mA output. The current value can be read out in keypad in <i>parameter 16-65 Analog Output 42 [mA]</i> .
[0]	No operation	There is no signal on the analog output.
[100]	Output frequency 0-20 mA	0 Hz = 0 mA; 100 Hz = 20 mA.
[101]	Reference 0-20 mA	<i>3-00 Reference Range</i> [Min - Max] 0% = 0 mA; 100% = 20 mA <i>3-00 Reference Range</i> [-Max - Max] -100% = 0 mA; 0% = 10 mA; +100% = 20 mA
[103]	Motor current 0-20 mA	Value is taken from <i>parameter 16-37 Inv. Max. Current</i> . Inverter max. current (160% current) is equal to 20 mA. Example: Inverter norm current (11 kW) = 24 A. 160% = 38.4 A. Motor norm current = 22 A Read-out 11.46 mA.

## Parameter Descriptions

### 6-50 Terminal 42 Output

Option:	Function:
	$\frac{20 \text{ mA} \times 22 \text{ A}}{38.4 \text{ A}} = 11.46 \text{ mA}$ <p>In case the norm motor current is equal to 20 mA, the output setting of parameter 6-52 Terminal 42 Output Max Scale is:</p> $\frac{I_{TRV200Max} \times 100}{I_{MotorNorm}} = \frac{38.4 \times 100}{22} = 175\%$
[104]	Torque rel to lim 0-20 mA The torque setting is related to setting in 4-16 Torque Limit Motor Mode
[105]	Torque rel to rated motor torque 0-20 mA The torque is related to the motor torque setting.
[106]	Power 0-20 mA Taken from 1-20 Motor Power [kW].
[107]	Speed 0-20 mA Taken from 3-03 Maximum Reference. 20 mA = value in 3-03 Maximum Reference
[108]	Torque ref. 0-20 mA Torque reference related to 160% torque.
[109]	Max Out Freq 0-20 mA In relation to 4-19 Max Output Frequency.
[134]	Torque% lim. 4-20 mA The torque setting is related to setting in 4-16 Torque Limit Motor Mode.
[135]	Torque% nom 4-20 mA The torque setting is related to the motor torque setting.
[141]	Bus ctrl. 0-20 mA, timeout 4-54 Warning Reference Low defines the behaviour of the analog output in case of bus time-out.
[142]	Bus ctrl. 4-20 mA, timeout 4-54 Warning Reference Low defines the behaviour of the analog output in case of bus time-out.
[150]	Max Out Freq 4-20 mA In relation to 4-19 Max Output Frequency.
[119]	Torque % lim
[149]	Torque % lim 4-20mA Analog output at zero torque = 12 mA. Motoric torque will increase the output current to max torque limit 20 mA (set in 4-16 Torque Limit Motor Mode). Generative torque will decrease the output to torque limit Generator Mode (set in 4-17 Torque Limit Generator Mode) Ex: 4-16 Torque Limit Motor Mode: 200% and 4-17 Torque Limit Generator Mode: 200%. 20 mA = 200% Motoric and 4 mA = 200% Generative.

### 6-50 Terminal 42 Output

Option:	Function:
	<p><b>Illustration 6.9</b></p>
[0] *	No operation When no signal on the analog output.
[52]	MCO 0-20mA
[53]	MCO 4-20mA
[100]	Output frequency 0 Hz = 0 mA; 100 Hz = 20 mA.
[101]	Reference 3-00 Reference Range [Min - Max] 0% = 0 mA; 100% = 20 mA 3-00 Reference Range [-Max - Max] -100% = 0 mA; 0% = 10 mA; +100% = 20 mA
[102]	Feedback
[103]	Motor current Value is taken from parameter 16-37 Inv. Max. Current. Inverter max. current (160% current) is equal to 20 mA. Example: Inverter norm current (11 kW) = 24 A. 160% = 38.4 A. Motor norm current = 22 A Read-out 11.46 mA. $\frac{I_{TRV200Max} \times 100}{I_{MotorNorm}} = \frac{38.4 \times 100}{22} = 175\%$ In case the norm motor current is equal to 20 mA, the output setting of parameter 6-52 Terminal 42 Output Max Scale is: $\frac{I_{DRIVEMax} \times 100}{I_{MotorNorm}} = \frac{38.4 \times 100}{22} = 175\%$
[104]	Torque rel to limit The torque setting is related to setting in 4-16 Torque Limit Motor Mode
[105]	Torq relate to rated The torque is related to the motor torque setting.
[106]	Power Taken from 1-20 Motor Power [kW].
[107]	Speed Taken from 3-03 Maximum Reference. 20 mA = value in 3-03 Maximum Reference
[108]	Torque Torque reference related to 160% torque.
[109]	Max Out Freq 0 Hz = 0 mA, 4-19 Max Output Frequency = 20 mA.
[130]	Output freq. 4-20mA 0 Hz = 4 mA, 100 Hz = 20 mA
[131]	Reference 4-20mA 3-00 Reference Range [Min-Max] 0% = 4 mA; 100% = 20 mA 3-00 Reference Range [-Max-Max] -100% = 4 mA; 0% = 12 mA; +100% = 20 mA
[132]	Feedback 4-20mA



## Parameter Descriptions

6

6-50 Terminal 42 Output		
Option:	Function:	
[133] Motor cur. 4-20mA	Value is taken from <i>parameter 16-37 Inv. Max. Current</i> . Inverter max. current (160% current) is equal to 20 mA. Example: Inverter norm current (11 kW) = 24 A. 160% = 38.4 A. Motor norm current = 22 A Read-out 11.46 mA. $\frac{16 \text{ mA} \times 22 \text{ A}}{38.4 \text{ A}} + 4 \text{ mA} = 13.17 \text{ mA}$ In case the norm motor current is equal to 20 mA, the output setting of 6-62 Terminal X30/8 Max. Scale is: $\frac{17RV200Max \times 100}{/MotorNorm} = \frac{38.4 \times 100}{22} = 175\%$	
[134] Torq.% lim 4-20 mA	The torque setting is related to setting in 4-16 Torque Limit Motor Mode.	
[135] Torq.% nom 4-20 mA	The torque setting is related to the motor torque setting.	
[136] Power 4-20mA	Taken from 1-20 Motor Power [kW]	
[137] Speed 4-20mA	Taken from 3-03 Maximum Reference. 20 mA = Value in 3-03 Maximum Reference.	
[138] Torque 4-20mA	Torque reference related to 160% torque.	
[139] Bus ctrl. 0-20 mA	An output value set from fieldbus process data. The output will work independently of internal functions in the frequency converter.	
[140] Bus ctrl. 4-20 mA	An output value set from fieldbus process data. The output will work independently of internal functions in the frequency converter.	
[141] Bus ctrl 0-20mA t.o.	4-54 Warning Reference Low defines the behaviour of the analog output in case of bus time-out.	
[142] Bus ctrl 4-20mA t.o.	4-54 Warning Reference Low defines the behaviour of the analog output in case of bus time-out.	
[150] Max Out Fr 4-20mA	0 Hz = 0 mA, 4-19 Max Output Frequency = 20 mA.	

6-51 Terminal 42 Output Min Scale		
Range:	Function:	
0 %* [0 - 200 %]	Scale for the minimum output (0 or 4 mA) of the analog signal at terminal 42. Set the value to be the percentage of the full range of the variable selected in 6-50 Terminal 42 Output.	

6-52 Terminal 42 Output Max Scale		
Range:	Function:	
100 %* [0 - 200 %]	Scale the maximum output of the selected analog signal at terminal 42. Set the value to the maximum value of the current signal output. Scale the output to give a current lower than 20 mA at full scale; or 20 mA at an output below 100% of the maximum signal value. If 20 mA is the desired output current at a value between 0 - 100% of the full-scale output, programme the percentage value in the parameter, i.e. 50% = 20 mA. If a current between 4 and 20 mA is desired at maximum output (100%), calculate the percentage value as follows:	

$$20 \text{ mA} / \text{desired maximum current} \times 100\%$$

$$\text{i.e. } 10 \text{ mA} : \frac{20}{10} \times 100 = 200\%$$

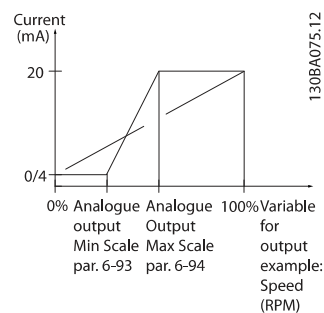

Illustration 6.10 Output Max Scale

6-53 Terminal 42 Output Bus Control		
Range:	Function:	
0 %* [0 - 100 %]	Holds the level of Output 42 if controlled by bus.	

## 6.8 Parameters: 7-\*\* Controllers

7-06 Speed PID Lowpass Filter Time		
Range:	Function:	
Size related* [0.1 - 100 ms]	Set a time constant for the speed control low-pass filter. The low-pass filter improves steady-state performance and dampens oscillations on the feedback signal. This is an advantage if there is a great amount on noise in the system, see <i>Illustration 6.11</i> . For example, if a time constant ( $\tau$ ) of 100 ms is programmed, the cut-off frequency for the low-pass filter is $1/0.1 = 10 \text{ RAD/s}$ , corresponding to $(10/2 \times \pi) = 1.6 \text{ Hz}$ . The PID regulator only regulates a feedback signal that varies by a frequency of less than 1.6 Hz. If the feedback signal varies by a higher frequency than 1.6 Hz, the PID regulator does not react. Practical settings of <i>parameter 7-06 Speed PID Lowpass Filter Time</i> taken from the number of pulses per revolutions from encoder:	
	<b>Encoder PPR</b>	<b>Parameter 7-06 Speed PID Lowpass Filter Time</b>
	512	10 ms
	1024	5 ms
	2048	2 ms
	4096	1 ms

### NOTICE

Severe filtering can be detrimental to dynamic performance.

This parameter is used with *1-00 Configuration Mode [1] Speed closed loop* and *[2] Torque control*.

Adjust the filter time in Flux Sensorless to 3-5 ms.

Feedback

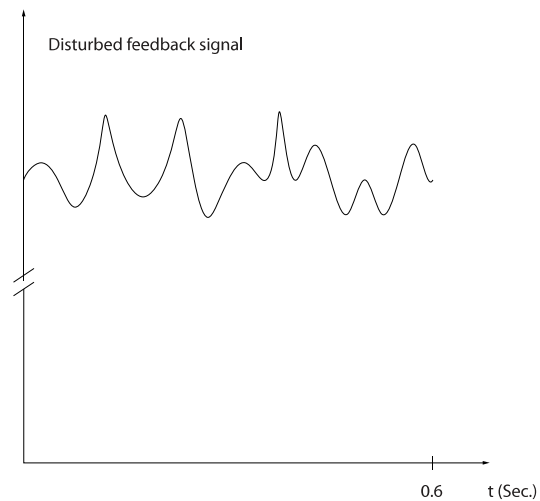

175ZA293.11

6

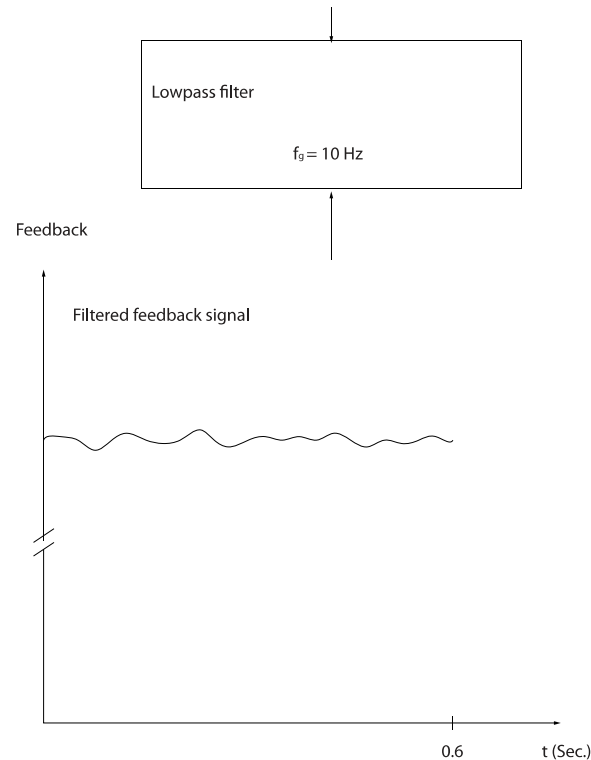

Illustration 6.11 Feedback Signal

### 6.8.1 7-2\* Process PID Feedback

Select the feedback sources for the Process PID Control, and how this feedback should be handled.

#### 7-20 Process CL Feedback 1 Resource

Option:	Function:	
		For process loop with current input, 54 switch has to be positioned on I (current).
[0]	No function	
[1]	Analog input 53	
[2] *	Analog input 54	



## Parameter Descriptions

7-39 On Reference Bandwidth		
Range:	Function:	
5 %* [0 - 200 %]	Enter the On Reference bandwidth. When the PID Control Error (the difference between the reference and the feedback) is less than the set value of this parameter the On Reference status bit is high, i.e. =1.	

### 6.8.2 7-6\* Feedback Conversion

Select how the signals from the feedback sources must be converted.

7-60 Feedback 1 Conversion		
Option:	Function:	
		Selects the conversion to apply to the feedback signal measured on the analog input selected as feedback 1 source in 7-20 <i>Process CL Feedback 1 Resource</i> .
[0] *	Linear	No conversion is applied. The feedback signal is assumed to be in the unit selected in 3-01 <i>Reference/Feedback Unit</i> and enters the process controller unchanged.
[1]	Square root	The square root of the feedback signal is calculated before passing it to the process controller.
[2]	Pressure to temperature	The feedback signal is a pressure with units as specified in 7-61 <i>Feedback 1 Source Unit</i> . It is converted to a temperature before passing it to the process controller. The pressure to temperature conversion is based on the refrigerant selected in 7-70 <i>Refrigerant</i> .

7-61 Feedback 1 Source Unit		
Option:	Function:	
		Select the pressure unit applicable to feedback source 1 defined in 7-20 <i>Process CL Feedback 1 Resource</i> .
[70]	mbar	
[71]	bar	
[72]	Pa	
[73]	kPa	
[74]	m WG	
[170]	psi	
[171]	lb/in2	
[172]	in WG	
[173]	ft WG	

7-62 Feedback 2 Conversion		
Option:	Function:	
		Selects the conversion to apply to the feedback signal measured on the analog input selected as feedback 2 source in 7-22 <i>Process CL Feedback 2 Resource</i> .

7-62 Feedback 2 Conversion		
Option:	Function:	
[0] *	Linear	No conversion is applied. The feedback signal is assumed to be in the unit selected in 3-01 <i>Reference/Feedback Unit</i> and enters the process controller unchanged.
[1]	Square root	The square root of the feedback signal is calculated before passing it to the process controller.
[2]	Pressure to temperature	The feedback signal is a pressure with units as specified in 7-62 <i>Feedback 2 Source Unit</i> . It is converted to a temperature before passing it to the process controller. The pressure to temperature conversion is based on the refrigerant selected in 7-70 <i>Refrigerant</i> .

7-63 Feedback 2 Source Unit		
Option:	Function:	
		Select the pressure unit applicable to feedback source 1 defined in 7-22 <i>Process CL Feedback 2 Resource</i> .
[70]	mbar	
[71]	bar	
[72]	Pa	
[73]	kPa	
[74]	m WG	
[170]	psi	
[171]	lb/in2	
[172]	in WG	
[173]	ft WG	

### 6.8.3 7-7\* Pressure to Temperature Conversion

The conversion of a feedback signal P in units of a pressure to a temperature T is accomplished via the formula:

$$T = A2 / (\log(P+1) - A1) - A3$$

where A1, A2 and A3 are refrigerant dependent constants.

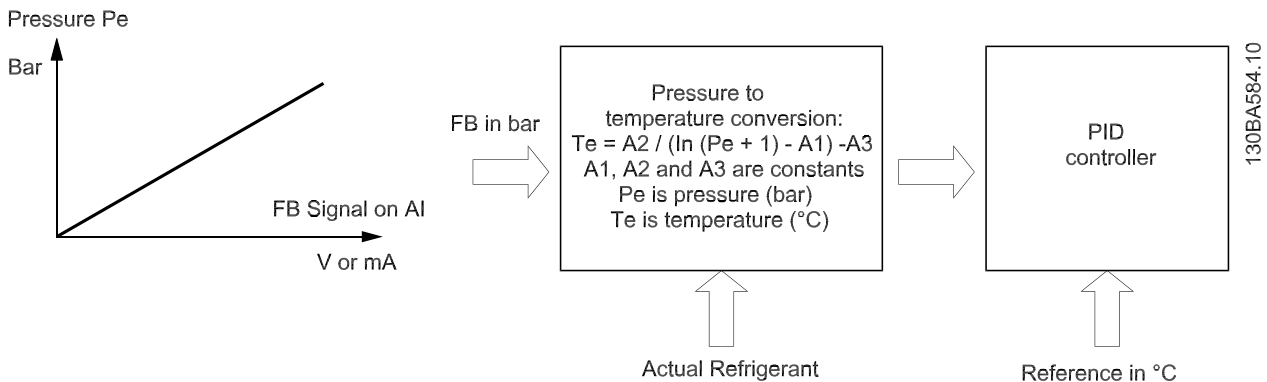

Illustration 6.12 Converting Pressure to Temperature

The parameters in this group allow selection of a refrigerant, which implicitly determines the constants A1, A2 and A3. Alternatively, user defined constants can be programmed explicitly.

7-70 Refrigerant		Function:
Option:		
[0]	R22	
[1]	R134a	
[2] *	R404A	
[3]	R407C	
[4]	R410A	
[5]	R502	
[6]	R744	
[7]	User defined	

7-71 User Defined Refrigerant A1		Function:
Range:		
[8.0000 – 12.0000]		Selects the value used for the constant A1 in the pressure to temperature conversion formula (see parameter group 7-7* Pressure to Temperature Conversion).

7-72 User Defined Refrigerant A2		Function:
Range:		
[-3000.00 – -1500.00]		Selects the value used for the constant A2 in the pressure to temperature conversion formula (see parameter group 7-7* Pressure to Temperature Conversion).

7-73 User Defined Refrigerant A3		Function:
Range:		
[200.000 – 300.000]		Selects the value used for the constant A3 in the pressure to temperature conversion formula (see parameter group 7-7* Pressure to Temperature Conversion).

### 6.8.4 7-8\* Thermostat/Pressostat Function

The Thermostat-Pressostat Function (TPF) can be used to stop and start the compressor when running in closed loop. The TPF monitors and compares the resulting feedback with the Cut-out value in 7-81 Cut-out Value. When the resulting feedback gets below 7-81 Cut-out Value a stop signal is generated and the compressor stops. When the resulting feedback gets above the Cut-in value in 7-82 Cut-in Value the stop signal is removed and the compressor starts again.

The Set-point should be set to a value in between Cut-in and Cut-out.

## Parameter Descriptions

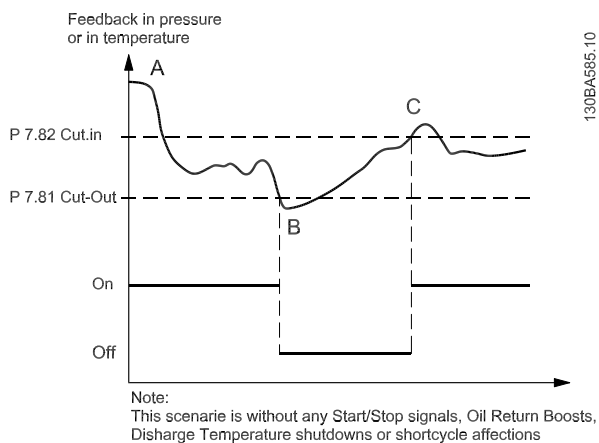

Illustration 6.13 Thermostat/Pressostat Function

6

Point A: At start-up the temperature will be higher than wanted in the evaporator and therefore a higher pressure than the Cut-in level and the compressor must run. Another situation could be that the start situation is where the feedback is between Cut-out and Cut-in. In that case, no STOP is initiated.

Point B: After some time the cut-out level may be reached and the compressor must be shut off.

Point C: Cut-in is reached and the compressor is restarted.

### **NOTICE**

When using the TPF together with the Cascade Controller further consideration must be taken. The Cut-Out value should be below the Override Bandwidth setting (see 25-21 *Override Bandwidth*). Cut-In should be set above the set-point and below the value for Staging Bandwidth (see 25-20 *Staging Bandwidth*).

#### 7-80 Thermostat/Pressostat Function

**Option:**                      **Function:**

[0] *	Off	Function is inactive
[1]	On	Function is active

#### 7-81 Cut-out Value

**Range:**                      **Function:**

1 bar*	[-3000 - par. 7-82]	Select the Cut-out Level where the stop signal is activated and the compressor stops.
--------	---------------------	---

#### 7-82 Cut-in Value

**Range:**                      **Function:**

3 bar*	[Par.7-81 - 3000]	Select the Cut-in Level where the stop signal is de-activated and the compressor starts.
--------	-------------------	--

## 6.9 Parameters: 8-\*\* Communications and Options

### 6.9.1 8-0\* General Settings

6

8-01 Control Site		
Option:	Function:	
		The setting in this parameter overrides the settings in <i>parameter 8-50 Coasting Select</i> to <i>parameter 8-56 Preset Reference Select</i> .
[0]	Digital and ctrl.word	Control by using both digital input and control word.
[1]	Digital only	Control by using digital inputs only.
[2]	Controlword only	Control by using control word only.

8-02 Control Word Source		
Option:	Function:	
		<p><b>NOTICE</b></p> <p><b>This parameter cannot be adjusted while the motor is running.</b></p> <p>Select the source of the control word: one of 2 serial interfaces or 4 installed options. During initial power-up, the frequency converter automatically sets this parameter to [3] <i>Option A</i>, if it detects a valid fieldbus option installed in slot A. If the option is removed, the frequency converter detects a change in the configuration, sets <i>parameter 8-02 Control Word Source</i> back to default setting RS-485, and the frequency converter trips. If an option is installed after initial power-up, the setting of <i>parameter 8-02 Control Word Source</i> does not change, but the frequency converter trips and displays: <i>Alarm 67 Option Changed</i>. When retrofitting a bus option into a frequency converter that did not have a bus option installed to begin with, take an ACTIVE decision to move the control to Bus based. This is done for safety reasons to avoid an accidental change.</p>
[0]	None	
[1]	FC RS485	
[2]	FC USB	
[3]	Option A	
[4]	Option B	
[5]	Option C0	
[6]	Option C1	
[30]	External Can	

8-03 Control Word Timeout Time		
Range:	Function:	
[1.0 s]	0.1-18000.0 s	Enter the maximum time expected to pass between the reception of two consecutive telegrams. If this time is exceeded, it indicates that the serial communication has stopped. The function selected in <i>parameter 8-04 Control Word Timeout Function</i> is then carried out. A valid control word triggers the time-out counter.
20 s*	[ 0.1 - 18000.0 s ]	Enter the maximum time expected to pass between the reception of two consecutive telegrams. If this time is exceeded, it indicates that the serial communication has stopped. The function selected in <i>parameter 8-04 Control Word Timeout Function</i> is then carried out. A valid control word triggers the time-out counter.

8-04 Control Word Timeout Function		
Select the time-out function. The time-out function activates when the control word fails to be updated within the time period specified in <i>8-03 Control Word Timeout Time</i> .		
Option:	Function:	
[0]	Off	Resumes control via serial bus (fieldbus or standard) using the most recent control word.
[1]	Freeze output	Freezes output frequency until communication resumes.
[2]	Stop	Stops with auto restart when communication resumes.
[3]	Jogging	Runs the motor at JOG frequency until communication resumes.
[4]	Max. speed	Runs the motor at maximum frequency until communication resumes.
[5]	Stop and trip	Stops the motor, then resets the frequency converter to restart: via the fieldbus, via [Reset], or via a digital input.
[7]	Select setup 1	Changes the set-up upon reestablishment of communication following a control word time-out. If communication resumes after a time-out, <i>parameter 8-05 End-of-Timeout Function</i> defines whether to resume the set-up used before the time-out, or to retain the set-up endorsed by the time-out function.
[8]	Select setup 2	See [7] <i>Select setup 1</i>
[9]	Select setup 3	See [7] <i>Select setup 1</i>
[10]	Select setup 4	See [7] <i>Select setup 1</i>
[26]	Trip	

## Parameter Descriptions

### NOTICE

To change the set-up after a time-out, the following configuration is required:

Set parameter 0-10 Active Set-up to [9] Multi set-up and select the relevant link in parameter 0-12 This Set-up Linked to.

8-05 End-of-Timeout Function		
Option:	Function:	
		Select the action after receiving a valid control word following a time-out. This parameter is active only when 8-04 Control Timeout Function is set to [7] Set-up 1, [8] Set-up 2, [9] Set-up 3 or [10] Set-up 4.
[0]	Hold set-up	Retains the set-up selected in 8-04 Control Timeout Function and displays a warning, until 8-06 Reset Control Timeout toggles. Then the frequency converter resumes its original set-up.
[1] *	Resume set-up	Resumes the set-up active before the time-out.

8-06 Reset Control Word Timeout		
This parameter is active only when [0] Hold set-up has been selected in parameter 8-05 End-of-Timeout Function.		
Option:	Function:	
[0] *	Do not reset	Retains the set-up specified in parameter 8-04 Control Word Timeout Function, following a control word time-out.
[1]	Do reset	Returns the frequency converter to the original set-up following a control word time-out. The frequency converter performs the reset and then immediately reverts to the [0] Do not reset setting

### 6.9.2 8-1\* Ctrl. Word Settings

8-10 Control Word Profile		
Select the interpretation of the control and status words corresponding to the installed fieldbus. Only the selections valid for the fieldbus installed in slot A will be visible in the keypad display.		
For guidelines in selection of [0] FC profile and [1] PROFIdrive profile, refer to the Serial communication via RS-485 Interface section in the Design Guide.		
For additional guidelines in the selection of [1] PROFIdrive profile, refer to the Operating Instructions for the installed fieldbus.		
Option:	Function:	
[0] *	FC profile	
[1]	PROFIdrive profile	

8-13 Configurable Status Word STW		
Option:	Function:	
[0]	No function	The input is always low.
[1] *	Profile Default	Depended on the profile set in 8-10 Control Profile.
[2]	Alarm 68 Only	The input goes high whenever Alarm 68 is active and goes low whenever no alarm 68 is active.
[3]	Trip excl Alarm 68	
[16]	T37 DI status	The input goes high whenever T37 has 0 V and goes low whenever T37 has 24 V.

### 6.9.3 8-3\* Drive Port Settings

8-30 Protocol		
Option:	Function:	
		Select the protocol to be used. Changing protocol is not effective until after powering off the frequency converter.
[0] *	FC	
[1]	FC MC	
[2]	Modbus RTU	

8-31 Address		
Range:	Function:	
Size related*	[ 1 - 255 ]	Enter the address for the Drive (standard) port. Valid range: 1-126.

8-32 FC Port Baud Rate		
Option:	Function:	
[0]	2400 Baud	Baud rate selection for the FC (standard) port.
[1]	4800 Baud	
[2]	9600 Baud	
[3]	19200 Baud	
[4]	38400 Baud	
[5]	57600 Baud	
[6]	76800 Baud	
[7]	115200 Baud	

8-33 Parity / Stop Bits		
Option:	Function:	
[0] *	Even Parity, 1 Stop Bit	
[1]	Odd Parity, 1 Stop Bit	
[2]	No Parity, 1 Stop Bit	
[3]	No Parity, 2 Stop Bits	



## Parameter Descriptions

6

8-35 Minimum Response Delay		
Range:		Function:
10 ms*	[ 1 - 10000 ms]	Specify the minimum delay time between receiving a request and transmitting a response. This is used for overcoming modem turnaround delays.

8-36 Max Response Delay		
Range:		Function:
Size related*	[ 11 - 10001 ms]	Specify the maximum permissible delay time between transmitting a request and receiving a response. If a response from the frequency converter is exceeding the time setting, then it is discarded.

8-37 Max Inter-Char Delay		
Range:		Function:
Size related*	[ 0.00 - 35.00 ms]	Specify the maximum permissible time interval between receipt of 2 bytes. This parameter activates time-out if transmission is interrupted. This parameter is active only when 8-30 Protocol is set to [1] FC MC protocol.

### 6.9.4 8-5\* Digital/Bus

Parameters for configuring the control word Digital/Bus merging.

NOTE: This parameter is active only when parameter 8-01 Control Site is set to [0] Digital and control word.

8-50 Coasting Select		
Option:		Function:
		Select control of the coasting function via the terminals (digital input) and/or via the bus.
[0]	Digital input	Activates Start command via a digital input.
[1]	Bus	Activates Start command via the serial communication port or fieldbus option.
[2]	Logic AND	Activates Start command via the fieldbus/serial communication port, AND additionally via one of the digital inputs.
[3] *	Logic OR	Activates Start command via the fieldbus/serial communication port OR via one of the digital inputs.

8-51 Quick Stop Select		
Select control of the Quick Stop function via the terminals (digital input) and/or via the bus.		
Option:		Function:
[0]	Digital input	
[1]	Bus	
[2]	Logic AND	
[3] *	Logic OR	

8-52 DC Brake Select		
Option:		Function:
		Select control of the DC brake via the terminals (digital input) and/or via the fieldbus. <b>NOTICE</b> Only selection [0] Digital input is available when 1-10 Motor Construction is set to [1] PM non-salient SPM.
[0]	Digital input	Activates Start command via a digital input.
[1]	Bus	Activates Start command via the serial communication port or fieldbus option.
[2]	Logic AND	Activates Start command via the fieldbus/serial communication port, AND additionally via one of the digital inputs.
[3]	Logic OR	Activates Start command via the fieldbus/serial communication port OR via one of the digital inputs.

8-53 Start Select		
Option:		Function:
		Select control of the frequency converter start function via the terminals (digital input) and/or via the fieldbus.
[0]	Digital input	Activates start command via a digital input.
[1]	Bus	Activates start command via the serial communication port or fieldbus option.
[2]	Logic AND	Activates start command via the fieldbus/serial communication port, AND additionally via one of the digital inputs.
[3] *	Logic OR	Activates start command via the fieldbus/serial communication port OR via one of the digital inputs.

8-54 Reversing Select		
Option:		Function:
[0]	Digital input	Select control of the frequency converter reverse function via the terminals (digital input) and/or via the fieldbus.
[1]	Bus	Activates the Reverse command via the serial communication port or fieldbus option.

## Parameter Descriptions

8-54 Reversing Select		
Option:	Function:	
[2]	Logic AND	Activates the Reverse command via the fieldbus/serial communication port, AND additionally via one of the digital inputs.
[3] *	Logic OR	Activates the Reverse command via the fieldbus/serial communication port OR via one of the digital inputs.

8-55 Set-up Select		
Option:	Function:	
		Select control of the frequency converter set-up selection via the terminals (digital input) and/or via the fieldbus.
[0]	Digital input	Activates the set-up selection via a digital input.
[1]	Bus	Activates the set-up selection via the serial communication port or fieldbus option.
[2]	Logic AND	Activates the set-up selection via the fieldbus/serial communication port, AND additionally via one of the digital inputs.
[3] *	Logic OR	Activate the set-up selection via the fieldbus/serial communication port OR via one of the digital inputs.

8-56 Preset Reference Select		
Option:	Function:	
		Select control of the preset reference selection via the terminals (digital input) and/or via the fieldbus.
[0]	Digital input	Activates preset reference selection via a digital input.
[1]	Bus	Activates preset reference selection via the serial communication port or fieldbus option.
[2]	Logic AND	Activates preset reference selection via the fieldbus/serial communication port, AND additionally via one of the digital inputs.
[3] *	Logic OR	Activates the preset reference selection via the fieldbus/serial communication port OR via one of the digital inputs.

### 6.9.5 8-8\* Drive Port Diagnostics

These parameters are used for monitoring the bus communication via the Drive Port.

8-80 Bus Message Count		
Range:	Function:	
0*	[0 - 0 ]	This parameter shows the number of valid telegrams detected on the bus.

8-81 Bus Error Count		
Range:	Function:	
0*	[0 - 0 ]	This parameter shows the number of telegrams with faults (e.g. CRC fault), detected on the bus.

8-82 Slave Messages Rcvd		
Range:	Function:	
0*	[0 - 0 ]	This parameter shows the number of valid telegrams addressed to the slave, sent by the frequency converter.

8-83 Slave Error Count		
Range:	Function:	
0*	[0 - 0 ]	This parameter shows the number of error telegrams, which could not be executed by the frequency converter.

### 6.9.6 8-9\* Bus Jog

8-90 Bus Jog 1 Speed		
Range:	Function:	
100 RPM*	[ 0 - par. 4-13 RPM]	Enter the jog speed. Activate this fixed jog speed via the serial port or fieldbus option.

8-91 Bus Jog 2 Speed		
Range:	Function:	
200 RPM*	[ 0 - par. 4-13 RPM]	Enter the jog speed. Activate this fixed jog speed via the serial port or fieldbus option.

## 6.10 Parameters: 13-\*\* Smart Logic Control

### 6.10.1 Prog. Features

Smart Logic Control (SLC) is essentially a sequence of user-defined actions (see *parameter 13-52 SL Controller Action* [x]) executed by the SLC when the associated user-defined event (see *parameter 13-51 SL Controller Event* [x]) is evaluated as TRUE by the SLC.

The condition for an event can be a particular status or that the output from a Logic Rule or a Comparator Operand becomes TRUE. That leads to an associated action as illustrated:

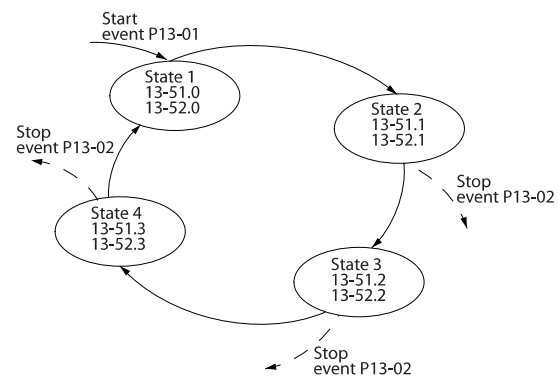

Illustration 6.15 Events and Actions

6

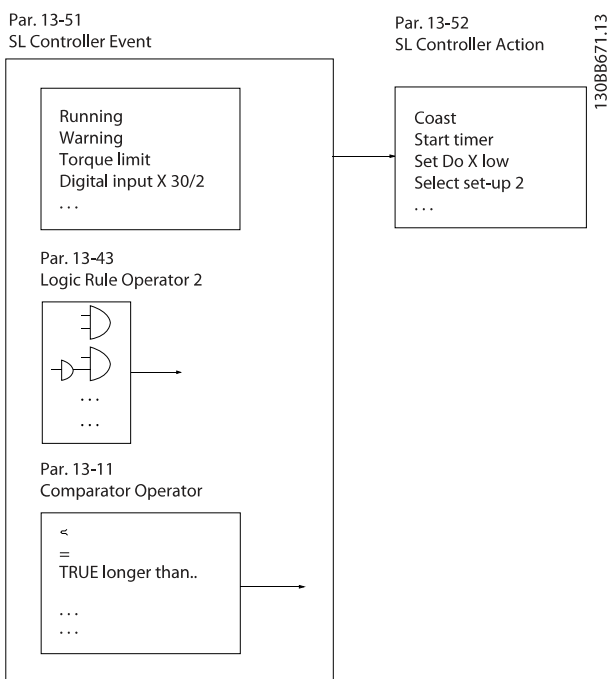

Illustration 6.14 Smart Logic Control (SLC)

Events and actions are each numbered and linked in pairs (states). This means that when event [0] is fulfilled (attains the value TRUE), action [0] is executed. After this, the conditions of event [1] are evaluated and if evaluated TRUE, action [1] is executed and so on. Only one event is evaluated at any time. If an event is evaluated as FALSE, nothing happens (in the SLC) during the current scan interval and no other events are evaluated. This means that when the SLC starts, it evaluates event [0] (and only event [0]) each scan interval. Only when event [0] is evaluated TRUE, the SLC executes action [0] and starts evaluating event [1]. It is possible to programme from 1 to 20 events and actions.

When the last event/action has been executed, the sequence starts over again from event [0]/action [0]. Illustration 6.15 shows an example with 3 event/actions:

#### Starting and stopping the SLC:

Starting and stopping the SLC can be done by selecting [1] On or [0] Off in 13-00 SL Controller Mode. The SLC always starts in state 0 (where it evaluates event [0]). The SLC starts when the Start Event (defined in parameter 13-01 Start Event) is evaluated as TRUE (provided that [1] On is selected in 13-00 SL Controller Mode). The SLC stops when the Stop Event (parameter 13-02 Stop Event) is TRUE. parameter 13-03 Reset SLC resets all SLC parameters and start programming from scratch.

#### NOTICE

SLC is only active in AUTO mode, not Hand On mode

### 6.10.2 13-0\* SLC Settings

Use the SLC settings to activate, deactivate and reset the Smart Logic Control sequence. The logic functions and comparators are always running in the background, which opens for separate control of digital inputs and outputs.

#### 13-00 SLC Controller Mode

Option: Function:

[0] *	Off	Disables the Smart Logic Control.
[1]	On	Enables the Smart Logic Control to start when a start command is present, e.g. via a digital input.

#### 13-01 Start Event

Select the boolean (TRUE or FALSE) input to activate Smart Logic Control.

Option: Function:

[0]	False	Select the boolean (TRUE or FALSE) input to activate Smart Logic Control. Enters the fixed value - FALSE
[1]	True	Enters the fixed value - TRUE.
[2]	Running	The motor is running.
[3]	In range	The motor is running within the programmed current and speed ranges set in 4-50 Warning Current Low to parameter 4-53 Warning Speed High.

## Parameter Descriptions

13-01 Start Event		
Select the boolean (TRUE or FALSE) input to activate Smart Logic Control.		
Option:	Function:	
[4]	On reference	The motor is running on reference.
[5]	Torque limit	The torque limit, set in <i>4-16 Torque Limit Motor Mode</i> or <i>4-17 Torque Limit Generator Mode</i> , has been exceeded.
[6]	Current Limit	The motor current limit, set in <i>parameter 4-18 Current Limit</i> , has been exceeded.
[7]	Out of current range	The motor current is outside the range set in <i>parameter 4-18 Current Limit</i> .
[8]	Below I low	The motor current is lower than set in <i>4-50 Warning Current Low</i> .
[9]	Above I high	The motor current is higher than set in <i>4-51 Warning Current High</i> .
[10]	Out of speed range	The speed is outside the range set in <i>4-52 Warning Speed Low</i> and <i>parameter 4-53 Warning Speed High</i> .
[11]	Below speed low	The output speed is lower than the setting in <i>4-52 Warning Speed Low</i> .
[12]	Above speed high	The output speed is higher than the setting in <i>parameter 4-53 Warning Speed High</i> .
[13]	Out of feedb. range	The feedback is outside the range set in <i>4-56 Warning Feedback Low</i> and <i>4-57 Warning Feedback High</i> .
[14]	Below feedb. low	The feedback is below the limit set in <i>4-56 Warning Feedback Low</i> .
[15]	Above feedb. high	The feedback is above the limit set in <i>4-57 Warning Feedback High</i> .
[16]	Thermal warning	The thermal warning turns on when the temperature exceeds the limit in the motor, the frequency converter, the brake resistor or the thermistor.
[17]	Mains out of range	The mains voltage is outside the specified voltage range.
[18]	Reversing	The output is high when the frequency converter is running counter clockwise (the logical product of the status bits "running" AND "reverse").
[19]	Warning	A warning is active.
[20]	Alarm (trip)	A (trip) alarm is active.
[21]	Alarm (trip lock)	A (Trip lock) alarm is active.
[22]	Comparator 0	Use the result of comparator 0.
[23]	Comparator 1	Use the result of comparator 1.
[24]	Comparator 2	Use the result of comparator 2.

13-01 Start Event		
Select the boolean (TRUE or FALSE) input to activate Smart Logic Control.		
Option:	Function:	
[25]	Comparator 3	Use the result of comparator 3.
[26]	Logic rule 0	Use the result of logic rule 0.
[27]	Logic rule 1	Use the result of logic rule 1.
[28]	Logic rule 2	Use the result of logic rule 2.
[29]	Logic rule 3	Use the result of logic rule 3.
[33]	Digital input DI18	Use the result of digital input 18.
[34]	Digital input DI19	Use the result of digital input 19.
[35]	Digital input DI27	Use the result of digital input 27.
[36]	Digital input DI29	Use the result of digital input 29.
[37]	Digital input DI32	Use the result of digital input 32.
[38]	Digital input DI33	Use the result of digital input 33.
[39]	Start command	A start command is issued.
[40]	Drive stopped	A stop command (Jog, Stop, Qstop, Coast) is issued – and not from the SLC itself.
[41]	Reset Trip	A reset is issued
[42]	Auto-reset Trip	An Auto reset is performed.
[43]	Ok key	[OK] is pressed. Only available on the graphical LCP.
[44]	Reset key	[Reset] is pressed. Only available on the graphical LCP.
[45]	Left key	[←] is pressed. Only available on the graphical LCP.
[46]	Right key	[→] is pressed. Only available on the graphical LCP.
[47]	Up key	[▲] is pressed. Only available on the graphical LCP.
[48]	Down key	[▼] is pressed. Only available on the graphical LCP.
[50]	Comparator 4	Use the result of comparator 4.
[51]	Comparator 5	Use the result of comparator 5.
[60]	Logic rule 4	Use the result of logic rule 4.
[61]	Logic rule 5	Use the result of logic rule 5.
[76]	Digital input x30/2	Use the value of x30/2 (MCB 101 GPIO)
[77]	Digital input x30/3	Use the value of x30/3 (MCB 101 GPIO)

## Parameter Descriptions

6

13-01 Start Event		
Select the boolean (TRUE or FALSE) input to activate Smart Logic Control.		
Option:	Function:	
[78]	Digital input x30/4	Use the value of x30/4 (MCB 101 GPIO)
[79]	Digital input x46/1	Use the value of x46/1 (MCB 113 Ext. Relay Card)
[80]	Digital input x46/3	Use the value of x46/3 (MCB 113 Ext. Relay Card)
[81]	Digital input x46/5	Use the value of x46/5 (MCB 113 Ext. Relay Card)
[82]	Digital input x46/7	Use the value of x46/7 (MCB 113 Ext. Relay Card)
[83]	Digital input x46/9	Use the value of x46/9 (MCB 113 Ext. Relay Card)
[84]	Digital input x46/11	Use the value of x46/11 (MCB 113 Ext. Relay Card)
[85]	Digital input x46/13	Use the value of x46/13 (MCB 113 Ext. Relay Card)
[94]	RS Flipflop 0	See parameter group 13-1* Comparators
[95]	RS Flipflop 1	See parameter group 13-1* Comparators
[96]	RS Flipflop 2	See parameter group 13-1* Comparators
[97]	RS Flipflop 3	See parameter group 13-1* Comparators
[98]	RS Flipflop 4	See parameter group 13-1* Comparators
[99]	RS Flipflop 5	See parameter group 13-1* Comparators
[100]	RS Flipflop 6	See parameter group 13-1* Comparators
[101]	RS Flipflop 7	See parameter group 13-1* Comparators

13-02 Stop Event		
Select the boolean (TRUE or FALSE) input to deactivate Smart Logic Control.		
Option:	Function:	
[0]	False	For descriptions [0]-[61], see <i>parameter 13-01 Start Event Start Event</i>
[1]	True	
[2]	Running	
[3]	In range	
[4]	On reference	
[5]	Torque limit	
[6]	Current Limit	
[7]	Out of current range	
[8]	Below I low	
[9]	Above I high	
[10]	Out of speed range	
[11]	Below speed low	
[12]	Above speed high	
[13]	Out of feedb. range	

13-02 Stop Event		
Select the boolean (TRUE or FALSE) input to deactivate Smart Logic Control.		
Option:	Function:	
[14]	Below feedb. low	
[15]	Above feedb. high	
[16]	Thermal warning	
[17]	Mains out of range	
[18]	Reversing	
[19]	Warning	
[20]	Alarm (trip)	
[21]	Alarm (trip lock)	
[22]	Comparator 0	
[23]	Comparator 1	
[24]	Comparator 2	
[25]	Comparator 3	
[26]	Logic rule 0	
[27]	Logic rule 1	
[28]	Logic rule 2	
[29]	Logic rule 3	
[30]	SL Time-out 0	
[31]	SL Time-out 1	
[32]	SL Time-out 2	
[33]	Digital input DI18	
[34]	Digital input DI19	
[35]	Digital input DI27	
[36]	Digital input DI29	
[37]	Digital input DI32	
[38]	Digital input DI33	
[39]	Start command	
[40]	Drive stopped	
[41]	Reset Trip	
[42]	Auto-reset Trip	
[43]	Ok key	[OK] is pressed. Only available on the graphical LCP.
[44]	Reset key	[Reset] is pressed. Only available on the graphical LCP.
[45]	Left key	[◀] is pressed. Only available on the graphical LCP.
[46]	Right key	[▶] is pressed. Only available on the graphical LCP.
[47]	Up key	[▲] is pressed. Only available on the graphical LCP.
[48]	Down key	[▼] is pressed. Only available on the graphical LCP.
[50]	Comparator 4	
[51]	Comparator 5	
[60]	Logic rule 4	
[61]	Logic rule 5	
[70]	SL Time-out 3	Smart Logic Controller timer 3 is timed out.

## Parameter Descriptions

13-02 Stop Event		
Select the boolean (TRUE or FALSE) input to deactivate Smart Logic Control.		
Option:	Function:	
[71]	SL Time-out 4	Smart Logic Controller timer 4 is timed out.
[72]	SL Time-out 5	Smart Logic Controller timer 5 is timed out.
[73]	SL Time-out 6	Smart Logic Controller timer 6 is timed out.
[74]	SL Time-out 7	Smart Logic Controller timer 7 is timed out.
[75]	Start command given	
[76]	Digital input x30/2	
[77]	Digital input x30/3	
[78]	Digital input x30/4	
[79]	Digital input x46/1	
[80]	Digital input x46/3	
[81]	Digital input x46/5	
[82]	Digital input x46/7	
[83]	Digital input x46/9	
[84]	Digital input x46/11	
[85]	Digital input x46/13	
[90]	ATEX ETR cur. warning	Selectable, if 1-90 Motor Thermal Protection is set to [20] ATEX ETR or [21] Advanced ETR. If the alarm 164 ATEX ETR cur.lim.alarm is active, the output is 1.
[91]	ATEX ETR cur. alarm	Selectable, if 1-90 Motor Thermal Protection is set to [20] ATEX ETR or [21] Advanced ETR. If the alarm 166 ATEX ETR freq.lim.alarm is active, the output is 1.
[92]	ATEX ETR freq. warning	Selectable, if 1-90 Motor Thermal Protection is set to [20] ATEX ETR or [21] Advanced ETR. If the alarm 163 ATEX ETR cur.lim.warning is active, the output is 1.
[93]	ATEX ETR freq. alarm	Selectable, if 1-90 Motor Thermal Protection is set to [20] ATEX ETR or [21] Advanced ETR. If the warning 165 ATEX ETR freq.lim.warning is active, the output is 1.
[94]	RS Flipflop 0	See parameter group 13-1* Comparators
[95]	RS Flipflop 1	See parameter group 13-1* Comparators
[96]	RS Flipflop 2	See parameter group 13-1* Comparators
[97]	RS Flipflop 3	See parameter group 13-1* Comparators

13-02 Stop Event		
Select the boolean (TRUE or FALSE) input to deactivate Smart Logic Control.		
Option:	Function:	
[98]	RS Flipflop 4	See parameter group 13-1* Comparators
[99]	RS Flipflop 5	See parameter group 13-1* Comparators
[100]	RS Flipflop 6	See parameter group 13-1* Comparators
[101]	RS Flipflop 7	See parameter group 13-1* Comparators
[102]	Relay 1	
[103]	Relay 2	
[104]	Relay 3	X47/MCB 113
[105]	Relay 4	X47/MCB 113
[106]	Relay 5	X47/MCB 113
[107]	Relay 6	X47/MCB 113
[108]	Relay 7	X34/MCB 105
[109]	Relay 8	X34/MCB 105
[110]	Relay 9	X34/MCB 105

13-03 Reset SLC		
Option:	Function:	
[0] *	Do not reset SLC	Retains programmed settings in all parameter group 13-*** Smart Logic Control.
[1]	Reset SLC	Resets all parameters in parameter group 13-*** Smart Logic Control to default settings.

### 6.10.3 13-1\* Comparators

Comparators are used for comparing continuous variables (i.e. output frequency, output current, analog input etc.) to fixed preset values.

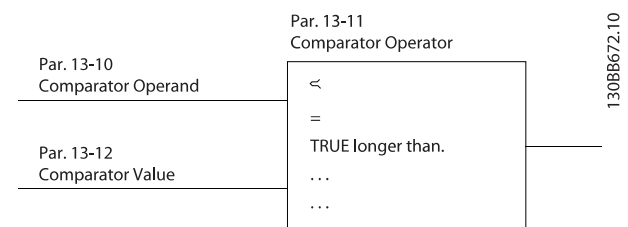

Illustration 6.16 Comparators

In addition, there are digital values that are compared to fixed time values. See explanation in *parameter 13-10 Comparator Operand*. Comparators are evaluated once in each scan interval. Use the result (TRUE or FALSE) directly. All parameters in this parameter group are array parameters with index 0 to 5. Select index 0 to

## Parameter Descriptions

programme comparator 0, select index 1 to programme comparator 1, and so on.

13-10 Comparator Operand		
Array [6]		
Option:	Function:	
	Options [1] to [31] are variables which are compared based on their values. Options [50] to [186] are digital values (TRUE/FALSE) where the comparison is based on the amount of time during which they are set to TRUE or FALSE, respectively. See <i>parameter 13-11 Comparator Operator</i> . Select the variable to be monitored by the comparator.	
[0]	DISABLED	The comparator is disabled.
[1]	Reference %	The resulting remote reference (not local) as a percentage.
[2]	Feedback %	[RPM] or [Hz], as set in parameter <i>0-02 Motor Speed Unit</i> .
[3]	Motor speed	[RPM] or [Hz], as set in parameter <i>0-02 Motor Speed Unit</i> .
[4]	Motor Current	[A]
[5]	Motor torque	[Nm]
[6]	Motor power	[kW] or [hp]
[7]	Motor voltage	[V]
[8]	DC-link voltage	[V]
[9]	Motor Thermal	Expressed as a percentage.
[10]	Drive thermal	Expressed as a percentage.
[11]	Heat sink temp.	Expressed as a percentage.
[12]	Analog input AI53	Expressed as a percentage.
[13]	Analog input AI54	Expressed as a percentage.
[14]	Analog input AIFB10	[V]. AIFB10 is internal 10 V supply.
[15]	Analog input AIS24V	[V] Analog input AICCT [17] [°]. AIS24V is switch mode power supply: SMPS 24V.
[17]	Analog input AICCT	[°]. AICCT is control card temperature.
[18]	Pulse input FI29	Expressed as a percentage.
[19]	Pulse input FI33	Expressed as a percentage.
[20]	Alarm number	The error number.
[21]	Warning number	
[22]	Analog input x30 11	

13-10 Comparator Operand		
Array [6]		
Option:	Function:	
[23]	Analog input x30 12	
[30]	Counter A	Number of counts.
[31]	Counter B	Number of counts.
[32]	Process PID Error	Value of the PID Error ( <i>18-90 Process PID Error</i> )
[33]	Process PID Output	Value of the PID Output ( <i>18-91 Process PID Output</i> )
[50]	FALSE	Enters the fixed value of false in the comparator.
[51]	TRUE	Enters the fixed value of true in the comparator.
[52]	Control ready	The control board receives supply voltage.
[53]	Drive ready	The frequency converter is ready for operation and applies a supply signal on the control board.
[54]	Running	The motor is running.
[55]	Reversing	The output is high when the frequency converter is running counter clockwise (the logical product of the status bits "running" AND "reverse").
[56]	In range	The motor is running within the programmed current and speed ranges set in <i>4-50 Warning Current Low</i> to <i>parameter 4-53 Warning Speed High</i> .
[60]	On reference	The motor is running on reference.
[61]	Below reference, low	The motor is running below the value given in <i>4-54 Warning Reference Low</i> .
[62]	Above ref, high	The motor is running above the value given in <i>4-55 Warning Reference High</i>
[65]	Torque limit	The torque limit, set in <i>4-16 Torque Limit Motor Mode</i> or <i>4-17 Torque Limit Generator Mode</i> , has been exceeded.
[66]	Current Limit	The motor current limit, set in <i>parameter 4-18 Current Limit</i> , has been exceeded.
[67]	Out of current range	The motor current is outside the range set in <i>parameter 4-18 Current Limit</i> .
[68]	Below I low	The motor current is lower than set in <i>4-50 Warning Current Low</i> .
[69]	Above I high	The motor current is higher than set in <i>4-51 Warning Current High</i> .
[70]	Out of speed range	The speed is outside the range set in <i>4-52 Warning Speed Low</i> and <i>parameter 4-53 Warning Speed High</i> .

## Parameter Descriptions

13-10 Comparator Operand		
Array [6]		
Option:	Function:	
[71]	Below speed low	The output speed is lower than the setting in <i>4-52 Warning Speed Low</i> .
[72]	Above speed high	The output speed is higher than the setting in <i>parameter 4-53 Warning Speed High</i> .
[75]	Out of feedback range	The feedback is outside the range set in <i>4-56 Warning Feedback Low</i> and <i>4-57 Warning Feedback High</i> .
[76]	Below feedback low	The feedback is below the limit set in <i>4-56 Warning Feedback Low</i> .
[77]	Above feedback high	The feedback is above the limit set in <i>4-57 Warning Feedback High</i> .
[80]	Thermal warning	This operand becomes true when the frequency converter detects any thermal warning, for instance, when the temperature exceeds the limit in the motor, the frequency converter, the brake resistor or thermistor.
[82]	Mains out of range	The mains voltage is outside the specified voltage range.
[85]	Warning	If a warning is triggered, this operand gets the warning number.
[86]	Alarm (trip)	A (trip) alarm is active.
[87]	Alarm (trip lock)	A (Trip lock) alarm is active.
[90]	Bus OK	Active communication (no time-out) via the serial communication port.
[91]	Torque limit & stop	If the frequency converter has received a stop signal and is at the torque limit, the signal is logic "0".
[92]	Brake fault (IGBT)	The brake IGBT is short circuited.
[93]	Mech. brake control	The mechanical brake is active.
[94]	Safe stop active	
[100]	Comparator 0	The result of comparator 0.
[101]	Comparator 1	The result of comparator 1.
[102]	Comparator 2	The result of comparator 2.
[103]	Comparator 3	The result of comparator 3.
[104]	Comparator 4	The result of comparator 4.
[105]	Comparator 5	The result of comparator 5.
[110]	Logic rule 0	The result of Logic rule 0.
[111]	Logic rule 1	The result of Logic rule 1.
[112]	Logic rule 2	The result of Logic rule 2.
[113]	Logic rule 3	The result of Logic rule 3.

13-10 Comparator Operand		
Array [6]		
Option:	Function:	
[114]	Logic rule 4	The result of Logic rule 4.
[115]	Logic rule 5	The result of Logic rule 5.
[120]	SL Time-out 0	The result of SLC timer 0.
[121]	SL Time-out 1	The result of SLC timer 1.
[122]	SL Time-out 2	The result of SLC timer 2.
[123]	SL Time-out 3	The result of SLC timer 3.
[124]	SL Time-out 4	The result of SLC timer 4.
[125]	SL Time-out 5	The result of SLC timer 5.
[126]	SL Time-out 6	The result of SLC timer 6.
[127]	SL Time-out 7	The result of SLC timer 7.
[130]	Digital input DI18	Digital input 18. High = True.
[131]	Digital input DI19	Digital input 19. High = True.
[132]	Digital input DI27	Digital input 27. High = True.
[133]	Digital input DI29	Digital input 29. High = True.
[134]	Digital input DI32	Digital input 32. High = True.
[135]	Digital input DI33	Digital input 33. High = True.
[150]	SL digital output A	Use the result of the SLC output A.
[151]	SL digital output B	Use the result of the SLC output B.
[152]	SL digital output C	Use the result of the SLC output C.
[153]	SL digital output D	Use the result of the SLC output D.
[154]	SL digital output E	Use the result of the SLC output E.
[155]	SL digital output F	Use the result of the SLC output F.
[160]	Relay 1	Relay 1 is active
[161]	Relay 2	Relay 2 is active
[162]	Relay 3	
[163]	Relay 4	
[164]	Relay 5	
[165]	Relay 6	
[166]	Relay 7	
[167]	Relay 8	
[168]	Relay 9	
[180]	Local reference active	High when <i>3-13 Reference Site = [2] Local</i> or when <i>3-13 Reference Site is [0] Linked to hand Auto</i> , at the same time as the keypad is in Hand On mode.



13-10 Comparator Operand		
Array [6]		
Option:	Function:	
[181]	Remote reference active	High when 3-13 Reference Site= [1] Remote or [0] Linked to hand/auto, while the keypad is in Auto On mode.
[182]	Start command	High when there is an active start command, and no stop command.
[183]	Drive stopped	A stop command (Jog, Stop, Qstop, Coast) is issued – and not from the SLC itself.
[185]	Drive in hand mode	High when the frequency converter is in Hand mode.
[186]	Drive in auto mode	High when the frequency converter is in Auto mode.
[187]	Start command given	
[190]	Digital input x30/2	
[191]	Digital input x30/3	
[192]	Digital input x30/4	
[193]	Digital input x46/1	
[194]	Digital input x46/2	
[195]	Digital input x46/3	
[196]	Digital input x46/4	
[197]	Digital input x46/5	
[198]	Digital input x46/6	
[199]	Digital input x46/7	

13-11 Comparator Operator		
Array [6]		
Option:	Function:	
		Select the operator to be used in the comparison. This is an array parameter containing comparator operators 0 to 5.
[0]	<	The result of the evaluation is TRUE, when the variable selected in <i>parameter 13-10 Comparator Operand</i> is smaller than the fixed value in <i>13-12 Comparator Value</i> . The result is FALSE, if the variable selected in <i>parameter 13-10 Comparator Operand</i> is greater than the fixed value in <i>13-12 Comparator Value</i> .
[1]	≈ (equal)	The result of the evaluation is TRUE, when the variable selected in <i>parameter 13-10 Comparator</i>

13-11 Comparator Operator		
Array [6]		
Option:	Function:	
		<i>Operand</i> is approximately equal to the fixed value in <i>13-12 Comparator Value</i> .
[2]	>	Inverse logic of option < [0].
[5]	TRUE longer than..	
[6]	FALSE longer than..	
[7]	TRUE shorter than..	
[8]	FALSE shorter than..	

13-12 Comparator Value		
Array [6]		
Range:	Function:	
Size related*	[-100000 - 100000 ]	Enter the 'trigger level' for the variable that is monitored by this comparator. This is an array parameter containing comparator values 0 to 5.

### 6.10.4 13-1\* RS Flip Flops

The Reset/Set Flip Flops hold the signal until set/reset.

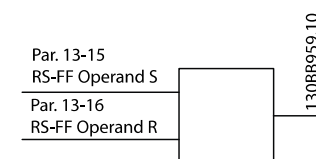

Illustration 6.17 Reset/Set Flip Flops

2 parameters are used and the output can be used in the logic rules and as events.

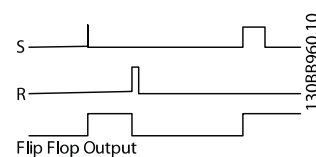

Illustration 6.18 Flip Flop Outputs

The 2 operators can be selected from a long list. As a special case, the same digital input can be used as both

## Parameter Descriptions

Set and Reset, making it possible to use the same digital input as start/stop. The following settings can be used to set up the same digital input as start/stop (example given with DI32 but is not a requirement).

Parameter	Setting	Notes
13-00 SL Controller Mode	On	
Parameter 13-01 Start Event	TRUE	
Parameter 13-02 Stop Event	FALSE	
Parameter 13-40 Logic Rule Boolean 1 [0]	[37] Digital Input DI32	
Parameter 13-42 Logic Rule Boolean 2 [0]	[2] Running	
Parameter 13-41 Logic Rule Operator 1 [0]	[3] AND NOT	
Parameter 13-40 Logic Rule Boolean 1 [1]	[37] Digital Input DI32	
Parameter 13-42 Logic Rule Boolean 2 [1]	[2] Running	
Parameter 13-41 Logic Rule Operator 1 [1]	[1] AND	
Parameter 13-15 RS-FF Operand S [0]	[26] Logicrule 0	Output from 13-41 [0]
Parameter 13-16 RS-FF Operand R [0]	[27] Logicrule 1	Output from 13-41 [1]
Parameter 13-51 SL Controller Event [0]	[94] RS Flipflop 0	Output from evaluating 13-15 and 13-16
Parameter 13-52 SL Controller Action [0]	[22] Run	
Parameter 13-51 SL Controller Event [1]	[27] Logicrule 1	
Parameter 13-52 SL Controller Action [1]	[24] Stop	

**Table 6.11 Operators**

13-15 RS-FF Operand S		
Option:	Function:	
[0]	False	
[1]	True	
[2]	Running	
[3]	In range	
[4]	On reference	
[5]	Torque limit	
[6]	Current Limit	
[7]	Out of current range	
[8]	Below I low	
[9]	Above I high	
[10]	Out of speed range	
[11]	Below speed low	
[12]	Above speed high	

13-15 RS-FF Operand S		
Option:	Function:	
[13]	Out of feedb. range	
[14]	Below feedb. low	
[15]	Above feedb. high	
[16]	Thermal warning	
[17]	Mains out of range	
[18]	Reversing	
[19]	Warning	
[20]	Alarm (trip)	
[21]	Alarm (trip lock)	
[22]	Comparator 0	
[23]	Comparator 1	
[24]	Comparator 2	
[25]	Comparator 3	
[26]	Logic rule 0	
[27]	Logic rule 1	
[28]	Logic rule 2	
[29]	Logic rule 3	
[30]	SL Time-out 0	
[31]	SL Time-out 1	
[32]	SL Time-out 2	
[33]	Digital input DI18	
[34]	Digital input DI19	
[35]	Digital input DI27	
[36]	Digital input DI29	
[37]	Digital input DI32	
[38]	Digital input DI33	
[39]	Start command	
[40]	Drive stopped	
[41]	Reset Trip	
[42]	Auto-reset Trip	
[43]	Ok key	[OK] is pressed. Only available on the graphical LCP.
[44]	Reset key	[Reset] is pressed. Only available on the graphical LCP.
[45]	Left key	[◀] is pressed. Only available on the graphical LCP.
[46]	Right key	[▶] is pressed. Only available on the graphical LCP.
[47]	Up key	[▲] is pressed. Only available on the graphical LCP.
[48]	Down key	[▼] is pressed. Only available on the graphical LCP.
[50]	Comparator 4	
[51]	Comparator 5	
[60]	Logic rule 4	
[61]	Logic rule 5	
[70]	SL Time-out 3	
[71]	SL Time-out 4	
[72]	SL Time-out 5	
[73]	SL Time-out 6	

## Parameter Descriptions

6

13-15 RS-FF Operand S		
Option:	Function:	
[74]	SL Time-out 7	
[75]	Start command given	
[76]	Digital input x30/2	
[77]	Digital input x30/3	
[78]	Digital input x30/4	
[79]	Digital input x46/1	
[80]	Digital input x46/3	
[81]	Digital input x46/5	
[82]	Digital input x46/7	
[83]	Digital input x46/9	
[84]	Digital input x46/11	
[85]	Digital input x46/13	
[90]	ATEX ETR cur. warning	
[91]	ATEX ETR cur. alarm	
[92]	ATEX ETR freq. warning	
[93]	ATEX ETR freq. alarm	
[94]	RS Flipflop 0	
[95]	RS Flipflop 1	
[96]	RS Flipflop 2	
[97]	RS Flipflop 3	
[98]	RS Flipflop 4	
[99]	RS Flipflop 5	
[100]	RS Flipflop 6	
[101]	RS Flipflop 7	
[102]	Relay 1	
[103]	Relay 2	
[104]	Relay 3	X47/MCB 113
[105]	Relay 4	X47/MCB 113
[106]	Relay 5	X47/MCB 113
[107]	Relay 6	X47/MCB 113
[108]	Relay 7	X34/MCB 105
[109]	Relay 8	X34/MCB 105
[110]	Relay 9	X34/MCB 105

13-16 RS-FF Operand R		
Option:	Function:	
[0]	False	
[1]	True	
[2]	Running	
[3]	In range	
[4]	On reference	
[5]	Torque limit	
[6]	Current Limit	
[7]	Out of current range	
[8]	Below I low	
[9]	Above I high	
[10]	Out of speed range	
[11]	Below speed low	
[12]	Above speed high	
[13]	Out of feedb. range	

13-16 RS-FF Operand R		
Option:	Function:	
[14]	Below feedb. low	
[15]	Above feedb. high	
[16]	Thermal warning	
[17]	Mains out of range	
[18]	Reversing	
[19]	Warning	
[20]	Alarm (trip)	
[21]	Alarm (trip lock)	
[22]	Comparator 0	
[23]	Comparator 1	
[24]	Comparator 2	
[25]	Comparator 3	
[26]	Logic rule 0	
[27]	Logic rule 1	
[28]	Logic rule 2	
[29]	Logic rule 3	
[30]	SL Time-out 0	
[31]	SL Time-out 1	
[32]	SL Time-out 2	
[33]	Digital input DI18	
[34]	Digital input DI19	
[35]	Digital input DI27	
[36]	Digital input DI29	
[37]	Digital input DI32	
[38]	Digital input DI33	
[39]	Start command	
[40]	Drive stopped	
[41]	Reset Trip	
[42]	Auto-reset Trip	
[43]	Ok key	[OK] is pressed. Only available on the graphical LCP.
[44]	Reset key	[Reset] is pressed. Only available on the graphical LCP.
[45]	Left key	[◀] is pressed. Only available on the graphical LCP.
[46]	Right key	[▶] is pressed. Only available on the graphical LCP.
[47]	Up key	[▲] is pressed. Only available on the graphical LCP.
[48]	Down key	[▼] is pressed. Only available on the graphical LCP.
[50]	Comparator 4	
[51]	Comparator 5	
[60]	Logic rule 4	
[61]	Logic rule 5	
[70]	SL Time-out 3	
[71]	SL Time-out 4	
[72]	SL Time-out 5	
[73]	SL Time-out 6	
[74]	SL Time-out 7	

## Parameter Descriptions

13-16 RS-FF Operand R		
Option:	Function:	
[75]	Start command given	
[76]	Digital input x30/2	
[77]	Digital input x30/3	
[78]	Digital input x30/4	
[79]	Digital input x46/1	
[80]	Digital input x46/3	
[81]	Digital input x46/5	
[82]	Digital input x46/7	
[83]	Digital input x46/9	
[84]	Digital input x46/11	
[85]	Digital input x46/13	
[90]	ATEX ETR cur. warning	
[91]	ATEX ETR cur. alarm	
[92]	ATEX ETR freq. warning	
[93]	ATEX ETR freq. alarm	
[94]	RS Flipflop 0	
[95]	RS Flipflop 1	
[96]	RS Flipflop 2	
[97]	RS Flipflop 3	
[98]	RS Flipflop 4	
[99]	RS Flipflop 5	
[100]	RS Flipflop 6	
[101]	RS Flipflop 7	
[102]	Relay 1	
[103]	Relay 2	
[104]	Relay 3	X47/MCB 113
[105]	Relay 4	X47/MCB 113
[106]	Relay 5	X47/MCB 113
[107]	Relay 6	X47/MCB 113
[108]	Relay 7	X34/MCB 105
[109]	Relay 8	X34/MCB 105
[110]	Relay 9	X34/MCB 105

### 6.10.5 13-2\* Timers

Use the result (TRUE or FALSE) from *timers* directly to define an *event* (see 13-51 *SL Controller Event*), or as boolean input in a *logic rule* (see 13-40 *Logic Rule Boolean 1*, 13-42 *Logic Rule Boolean 2* or 13-44 *Logic Rule Boolean 3*). A timer is only FALSE when started by an action (i.e. [29] *Start timer 1*) until the timer value entered in this parameter is elapsed. Then it becomes TRUE again. All parameters in this parameter group are array parameters with index 0 to 2. Select index 0 to program Timer 0, select index 1 to program Timer 1, and so on.

13-20 SL Controller Timer		
Range:	Function:	
Size related*	[ 0 - 0 ]	Enter the value to define the duration of the FALSE output from the programmed timer. A timer is only FALSE if it is started

13-20 SL Controller Timer		
Range:	Function:	
		by an action (i.e. [29] <i>Start timer 1</i> ) and until the given timer value has elapsed.

### 6.10.6 13-4\* Logic Rules

Combine up to 3 boolean inputs (TRUE/FALSE inputs) from timers, comparators, digital inputs, status bits and events using the logical operators AND, OR, and NOT. Select boolean inputs for the calculation in 13-40 *Logic Rule Boolean 1*, 13-42 *Logic Rule Boolean 2* and 13-44 *Logic Rule Boolean 3*. Define the operators used to logically combine the selected inputs in *parameter 13-41 Logic Rule Operator 1* and *parameter 13-43 Logic Rule Operator 2*.

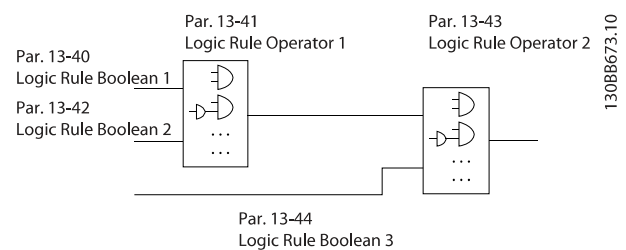

Illustration 6.19 Logic Rules

#### Priority of calculation

The results of 13-40 *Logic Rule Boolean 1*, *parameter 13-41 Logic Rule Operator 1* and 13-42 *Logic Rule Boolean 2* are calculated first. The outcome (TRUE/FALSE) of this calculation is combined with the settings of *parameter 13-43 Logic Rule Operator 2* and 13-44 *Logic Rule Boolean 3*, yielding the final result (TRUE/FALSE) of the logic rule.

13-40 Logic Rule Boolean 1		
Option:	Function:	
[0]	False	Select the first boolean (TRUE or FALSE) input for the selected logic rule. See <i>parameter 13-01 Start Event</i> ([0] - [61]) and <i>parameter 13-02 Stop Event</i> ([70] - [75]) for further description.
[1]	True	
[2]	Running	
[3]	In range	
[4]	On reference	
[5]	Torque limit	
[6]	Current Limit	
[7]	Out of current range	
[8]	Below I low	
[9]	Above I high	

## Parameter Descriptions

6

13-40 Logic Rule Boolean 1		
Array [6]		
Option:	Function:	
[10]	Out of speed range	
[11]	Below speed low	
[12]	Above speed high	
[13]	Out of feedb. range	
[14]	Below feedb. low	
[15]	Above feedb. high	
[16]	Thermal warning	
[17]	Mains out of range	
[18]	Reversing	
[19]	Warning	
[20]	Alarm (trip)	
[21]	Alarm (trip lock)	
[22]	Comparator 0	
[23]	Comparator 1	
[24]	Comparator 2	
[25]	Comparator 3	
[26]	Logic rule 0	
[27]	Logic rule 1	
[28]	Logic rule 2	
[29]	Logic rule 3	
[30]	SL Time-out 0	
[31]	SL Time-out 1	
[32]	SL Time-out 2	
[33]	Digital input DI18	
[34]	Digital input DI19	
[35]	Digital input DI27	
[36]	Digital input DI29	
[37]	Digital input DI32	
[38]	Digital input DI33	
[39]	Start command	
[40]	Drive stopped	
[41]	Reset Trip	
[42]	Auto-reset Trip	
[43]	Ok key	[OK] is pressed. Only available on the graphical LCP.
[44]	Reset key	[Reset] is pressed. Only available on the graphical LCP.
[45]	Left key	[◀] is pressed. Only available on the graphical LCP.
[46]	Right key	[▶] is pressed. Only available on the graphical LCP.
[47]	Up key	[▲] is pressed. Only available on the graphical LCP.
[48]	Down key	[▼] is pressed. Only available on the graphical LCP.
[50]	Comparator 4	
[51]	Comparator 5	
[60]	Logic rule 4	
[61]	Logic rule 5	

13-40 Logic Rule Boolean 1		
Array [6]		
Option:	Function:	
[70]	SL Time-out 3	
[71]	SL Time-out 4	
[72]	SL Time-out 5	
[73]	SL Time-out 6	
[74]	SL Time-out 7	
[75]	Start command given	
[76]	Digital input x30/2	
[77]	Digital input x30/3	
[78]	Digital input x30/4	
[79]	Digital input x46/1	
[80]	Digital input x46/3	
[81]	Digital input x46/5	
[82]	Digital input x46/7	
[83]	Digital input x46/9	
[84]	Digital input x46/11	
[85]	Digital input x46/13	
[90]	ATEX ETR cur. warning	Selectable, if 1-90 Motor Thermal Protection is set to [20] ATEX ETR or [21] Advanced ETR. If the alarm 164 ATEX ETR cur.lim.alarm is active, the output is 1.
[91]	ATEX ETR cur. alarm	Selectable, if 1-90 Motor Thermal Protection is set to [20] ATEX ETR or [21] Advanced ETR. If the alarm 166 ATEX ETR freq.lim.alarm is active, the output is 1.
[92]	ATEX ETR freq. warning	Selectable, if 1-90 Motor Thermal Protection is set to [20] ATEX ETR or [21] Advanced ETR. If the alarm 163 ATEX ETR cur.lim.warning is active, the output is 1.
[93]	ATEX ETR freq. alarm	Selectable, if 1-90 Motor Thermal Protection is set to [20] ATEX ETR or [21] Advanced ETR. If the warning 165 ATEX ETR freq.lim.warning is active, the output is 1.
[94]	RS Flipflop 0	See parameter group 13-1* Comparators
[95]	RS Flipflop 1	See parameter group 13-1* Comparators
[96]	RS Flipflop 2	See parameter group 13-1* Comparators
[97]	RS Flipflop 3	See parameter group 13-1* Comparators
[98]	RS Flipflop 4	See parameter group 13-1* Comparators
[99]	RS Flipflop 5	See parameter group 13-1* Comparators

## Parameter Descriptions

13-40 Logic Rule Boolean 1		
Array [6]		
Option:	Function:	
[100]	RS Flipflop 6	See parameter group 13-1* <i>Comparators</i>
[101]	RS Flipflop 7	See parameter group 13-1* <i>Comparators</i>
[102]	Relay 1	
[103]	Relay 2	
[104]	Relay 3	X47/MCB 113
[105]	Relay 4	X47/MCB 113
[106]	Relay 5	X47/MCB 113
[107]	Relay 6	X47/MCB 113
[108]	Relay 7	X34/MCB 105
[109]	Relay 8	X34/MCB 105
[110]	Relay 9	X34/MCB 105

13-41 Logic Rule Operator 1		
Array [6]		
Option:	Function:	
		Select the first logical operator to use on the Boolean inputs from 13-40 <i>Logic Rule Boolean 1</i> and 13-42 <i>Logic Rule Boolean 2</i> . Parameter numbers in square brackets stand for the boolean inputs of parameters in group 13-**. <i>Smart Logic Control</i> .
[0]	DISABLED	Ignores 13-42 <i>Logic Rule Boolean 2</i> , parameter 13-43 <i>Logic Rule Operator 2</i> , and 13-44 <i>Logic Rule Boolean 3</i> .
[1]	AND	Evaluates the expression [13-40] AND [13-42].
[2]	OR	Evaluates the expression [13-40] OR [13-42].
[3]	AND NOT	Evaluates the expression [13-40] AND NOT [13-42].
[4]	OR NOT	Evaluates the expression [13-40] OR NOT [13-42].
[5]	NOT AND	Evaluates the expression NOT [13-40] AND [13-42].
[6]	NOT OR	Evaluates the expression NOT [13-40] OR [13-42].
[7]	NOT AND NOT	Evaluates the expression NOT [13-40] AND NOT [13-42].
[8]	NOT OR NOT	Evaluates the expression NOT [13-40] OR NOT [13-42].

13-42 Logic Rule Boolean 2		
Array [6]		
Option:	Function:	
[0]	False	Select the second boolean (TRUE or FALSE) input for the selected logic rule. See parameter 13-01 <i>Start Event</i> ([0] - [61]) and parameter 13-02 <i>Stop Event</i> ([70] - [75]) for further description.
[1]	True	
[2]	Running	
[3]	In range	
[4]	On reference	
[5]	Torque limit	
[6]	Current Limit	
[7]	Out of current range	
[8]	Below I low	
[9]	Above I high	
[10]	Out of speed range	
[11]	Below speed low	
[12]	Above speed high	
[13]	Out of feedb. range	
[14]	Below feedb. low	
[15]	Above feedb. high	
[16]	Thermal warning	
[17]	Mains out of range	
[18]	Reversing	
[19]	Warning	
[20]	Alarm (trip)	
[21]	Alarm (trip lock)	
[22]	Comparator 0	
[23]	Comparator 1	
[24]	Comparator 2	
[25]	Comparator 3	
[26]	Logic rule 0	
[27]	Logic rule 1	
[28]	Logic rule 2	
[29]	Logic rule 3	
[30]	SL Time-out 0	
[31]	SL Time-out 1	
[32]	SL Time-out 2	
[33]	Digital input DI18	
[34]	Digital input DI19	
[35]	Digital input DI27	
[36]	Digital input DI29	
[37]	Digital input DI32	
[38]	Digital input DI33	
[39]	Start command	
[40]	Drive stopped	
[41]	Reset Trip	
[42]	Auto-reset Trip	
[43]	Ok key	[OK] is pressed. Only available on the graphical LCP.

## Parameter Descriptions

6

13-42 Logic Rule Boolean 2		
Array [6]		
Option:	Function:	
[44]	Reset key	[Reset] is pressed. Only available on the graphical LCP.
[45]	Left key	[◀] is pressed. Only available on the graphical LCP.
[46]	Right key	[▶] is pressed. Only available on the graphical LCP.
[47]	Up key	[▲] is pressed. Only available on the graphical LCP.
[48]	Down key	[▼] is pressed. Only available on the graphical LCP.
[50]	Comparator 4	
[51]	Comparator 5	
[60]	Logic rule 4	
[61]	Logic rule 5	
[70]	SL Time-out 3	
[71]	SL Time-out 4	
[72]	SL Time-out 5	
[73]	SL Time-out 6	
[74]	SL Time-out 7	
[75]	Start command given	
[76]	Digital input x30/2	
[77]	Digital input x30/3	
[78]	Digital input x30/4	
[79]	Digital input x46/1	
[80]	Digital input x46/3	
[81]	Digital input x46/5	
[82]	Digital input x46/7	
[83]	Digital input x46/9	
[84]	Digital input x46/11	
[85]	Digital input x46/13	
[90]	ATEX ETR cur. warning	Selectable, if <i>1-90 Motor Thermal Protection</i> is set to [20] <i>ATEX ETR</i> or [21] <i>Advanced ETR</i> . If the alarm 164 ATEX ETR cur.lim.alarm is active, the output is 1.
[91]	ATEX ETR cur. alarm	Selectable, if <i>1-90 Motor Thermal Protection</i> is set to [20] <i>ATEX ETR</i> or [21] <i>Advanced ETR</i> . If the alarm 166 ATEX ETR freq.lim.alarm is active, the output is 1.
[92]	ATEX ETR freq. warning	Selectable, if <i>1-90 Motor Thermal Protection</i> is set to [20] <i>ATEX ETR</i> or [21] <i>Advanced ETR</i> . If the alarm 163 ATEX ETR cur.lim.warning is active, the output is 1.
[93]	ATEX ETR freq. alarm	Selectable, if <i>1-90 Motor Thermal Protection</i> is set to [20] <i>ATEX ETR</i> or [21] <i>Advanced ETR</i> . If the warning 165 ATEX ETR

13-42 Logic Rule Boolean 2		
Array [6]		
Option:	Function:	
		freq.lim.warning is active, the output is 1.
[94]	RS Flipflop 0	See 13-1* <i>Comparators</i>
[95]	RS Flipflop 1	See 13-1* <i>Comparators</i>
[96]	RS Flipflop 2	See 13-1* <i>Comparators</i>
[97]	RS Flipflop 3	See 13-1* <i>Comparators</i>
[98]	RS Flipflop 4	See 13-1* <i>Comparators</i>
[99]	RS Flipflop 5	See 13-1* <i>Comparators</i>
[100]	RS Flipflop 6	See 13-1* <i>Comparators</i>
[101]	RS Flipflop 7	See 13-1* <i>Comparators</i>
[102]	Relay 1	
[103]	Relay 2	
[104]	Relay 3	X47/MCB 113
[105]	Relay 4	X47/MCB 113
[106]	Relay 5	X47/MCB 113
[107]	Relay 6	X47/MCB 113
[108]	Relay 7	X34/MCB 105
[109]	Relay 8	X34/MCB 105
[110]	Relay 9	X34/MCB 105

## Parameter Descriptions

13-43 Logic Rule Operator 2		
Array [6]		
Option:	Function:	
	<p>Select the second logical operator to be used on the boolean input calculated in <i>13-40 Logic Rule Boolean 1</i>, <i>parameter 13-41 Logic Rule Operator 1</i>, and <i>13-42 Logic Rule Boolean 2</i>, and the boolean input coming from <i>13-42 Logic Rule Boolean 2</i>.</p> <p>[13-44] signifies the boolean input of <i>13-44 Logic Rule Boolean 3</i>.</p> <p>[13-40/13-42] signifies the boolean input calculated in <i>13-40 Logic Rule Boolean 1</i>, <i>parameter 13-41 Logic Rule Operator 1</i>, and <i>13-42 Logic Rule Boolean 2</i>. [0] Disabled (factory setting). select this option to ignore <i>13-44 Logic Rule Boolean 3</i>.</p>	
[0]	DISABLED	
[1]	AND	
[2]	OR	
[3]	AND NOT	
[4]	OR NOT	
[5]	NOT AND	
[6]	NOT OR	
[7]	NOT AND NOT	
[8]	NOT OR NOT	

13-44 Logic Rule Boolean 3		
Array [6]		
Option:	Function:	
[0]	False	Select the third boolean (TRUE or FALSE) input for the selected logic rule. See <i>parameter 13-01 Start Event</i> ([0] - [61]) and <i>parameter 13-02 Stop Event</i> ([70] - [75]) for further description.
[1]	True	
[2]	Running	
[3]	In range	
[4]	On reference	
[5]	Torque limit	
[6]	Current Limit	
[7]	Out of current range	
[8]	Below I low	
[9]	Above I high	
[10]	Out of speed range	
[11]	Below speed low	
[12]	Above speed high	
[13]	Out of feedb. range	
[14]	Below feedb. low	
[15]	Above feedb. high	
[16]	Thermal warning	
[17]	Mains out of range	

13-44 Logic Rule Boolean 3		
Array [6]		
Option:	Function:	
[18]	Reversing	
[19]	Warning	
[20]	Alarm (trip)	
[21]	Alarm (trip lock)	
[22]	Comparator 0	
[23]	Comparator 1	
[24]	Comparator 2	
[25]	Comparator 3	
[26]	Logic rule 0	
[27]	Logic rule 1	
[28]	Logic rule 2	
[29]	Logic rule 3	
[30]	SL Time-out 0	
[31]	SL Time-out 1	
[32]	SL Time-out 2	
[33]	Digital input DI18	
[34]	Digital input DI19	
[35]	Digital input DI27	
[36]	Digital input DI29	
[37]	Digital input DI32	
[38]	Digital input DI33	
[39]	Start command	
[40]	Drive stopped	
[41]	Reset Trip	
[42]	Auto-reset Trip	
[43]	Ok key	[OK] is pressed. Only available on the graphical LCP.
[44]	Reset key	[Reset] is pressed. Only available on the graphical LCP.
[45]	Left key	[◀] is pressed. Only available on the graphical LCP.
[46]	Right key	[▶] is pressed. Only available on the graphical LCP.
[47]	Up key	[▲] is pressed. Only available on the graphical LCP.
[48]	Down key	[▼] is pressed. Only available on the graphical LCP.
[50]	Comparator 4	
[51]	Comparator 5	
[60]	Logic rule 4	
[61]	Logic rule 5	
[70]	SL Time-out 3	
[71]	SL Time-out 4	
[72]	SL Time-out 5	
[73]	SL Time-out 6	
[74]	SL Time-out 7	
[75]	Start command given	
[76]	Digital input x30/2	
[77]	Digital input x30/3	



## Parameter Descriptions

6

13-44 Logic Rule Boolean 3		
Array [6]		
Option:	Function:	
[78]	Digital input x30/4	
[79]	Digital input x46/1	
[80]	Digital input x46/3	
[81]	Digital input x46/5	
[82]	Digital input x46/7	
[83]	Digital input x46/9	
[84]	Digital input x46/11	
[85]	Digital input x46/13	
[90]	ATEX ETR cur. warning	Selectable, if 1-90 Motor Thermal Protection is set to [20] ATEX ETR or [21] Advanced ETR. If the alarm 164 ATEX ETR cur.lim.alarm is active, the output is 1.
[91]	ATEX ETR cur. alarm	Selectable, if 1-90 Motor Thermal Protection is set to [20] ATEX ETR or [21] Advanced ETR. If the alarm 166 ATEX ETR freq.lim.alarm is active, the output is 1.
[92]	ATEX ETR freq. warning	Selectable, if 1-90 Motor Thermal Protection is set to [20] ATEX ETR or [21] Advanced ETR. If the alarm 163 ATEX ETR cur.lim.warning is active, the output is 1.
[93]	ATEX ETR freq. alarm	Selectable, if 1-90 Motor Thermal Protection is set to [20] ATEX ETR or [21] Advanced ETR]. If the warning 165 ATEX ETR freq.lim.warning is active, the output is 1.
[94]	RS Flipflop 0	See parameter group 13-1* Comparators
[95]	RS Flipflop 1	See parameter group 13-1* Comparators
[96]	RS Flipflop 2	See parameter group 13-1* Comparators
[97]	RS Flipflop 3	See parameter group 13-1* Comparators
[98]	RS Flipflop 4	See parameter group 13-1* Comparators
[99]	RS Flipflop 5	See parameter group 13-1* Comparators
[100]	RS Flipflop 6	See parameter group 13-1* Comparators
[101]	RS Flipflop 7	See parameter group 13-1* Comparators
[102]	Relay 1	
[103]	Relay 2	
[104]	Relay 3	X47/MCB 113

13-44 Logic Rule Boolean 3		
Array [6]		
Option:	Function:	
[105]	Relay 4	X47/MCB 113
[106]	Relay 5	X47/MCB 113
[107]	Relay 6	X47/MCB 113
[108]	Relay 7	X34/MCB 105
[109]	Relay 8	X34/MCB 105
[110]	Relay 9	X34/MCB 105

### 6.10.7 13-5\* States

13-51 SL Controller Event		
Array [20]		
Option:	Function:	
[0]	False	Select the boolean input (TRUE or FALSE) to define the Smart Logic Controller event. See parameter 13-01 Start Event ([0] - [61]) and parameter 13-02 Stop Event ([70] - [74]) for further description.
[1]	True	
[2]	Running	
[3]	In range	
[4]	On reference	
[5]	Torque limit	
[6]	Current Limit	
[7]	Out of current range	
[8]	Below I low	
[9]	Above I high	
[10]	Out of speed range	
[11]	Below speed low	
[12]	Above speed high	
[13]	Out of feedb. range	
[14]	Below feedb. low	
[15]	Above feedb. high	
[16]	Thermal warning	
[17]	Mains out of range	
[18]	Reversing	
[19]	Warning	
[20]	Alarm (trip)	
[21]	Alarm (trip lock)	
[22]	Comparator 0	
[23]	Comparator 1	
[24]	Comparator 2	
[25]	Comparator 3	
[26]	Logic rule 0	
[27]	Logic rule 1	
[28]	Logic rule 2	
[29]	Logic rule 3	

## Parameter Descriptions

13-51 SL Controller Event		
Array [20]		
Option:	Function:	
[30]	SL Time-out 0	
[31]	SL Time-out 1	
[32]	SL Time-out 2	
[33]	Digital input DI18	
[34]	Digital input DI19	
[35]	Digital input DI27	
[36]	Digital input DI29	
[37]	Digital input DI32	
[38]	Digital input DI33	
[39]	Start command	
[40]	Drive stopped	
[41]	Reset Trip	
[42]	Auto-reset Trip	
[43]	Ok key	[OK] is pressed. Only available on the graphical LCP.
[44]	Reset key	[Reset] is pressed. Only available on the graphical LCP.
[45]	Left key	[◀] is pressed. Only available on the graphical LCP.
[46]	Right key	[▶] is pressed. Only available on the graphical LCP.
[47]	Up key	[▲] is pressed. Only available on the graphical LCP.
[48]	Down key	[▼] is pressed. Only available on the graphical LCP.
[50]	Comparator 4	
[51]	Comparator 5	
[60]	Logic rule 4	
[61]	Logic rule 5	
[70]	SL Time-out 3	
[71]	SL Time-out 4	
[72]	SL Time-out 5	
[73]	SL Time-out 6	
[74]	SL Time-out 7	
[75]	Start command given	
[76]	Digital input x30/2	
[77]	Digital input x30/3	
[78]	Digital input x30/4	
[79]	Digital input x46/1	
[80]	Digital input x46/3	
[81]	Digital input x46/5	
[82]	Digital input x46/7	
[83]	Digital input x46/9	
[84]	Digital input x46/11	
[85]	Digital input x46/13	
[90]	ATEX ETR cur. warning	Selectable, if 1-90 Motor Thermal Protection is set to [20] ATEX ETR or [21] Advanced ETR. If the alarm

13-51 SL Controller Event		
Array [20]		
Option:	Function:	
		164 ATEX ETR cur.lim.alarm is active, the output is 1.
[91]	ATEX ETR cur. alarm	Selectable, if 1-90 Motor Thermal Protection is set to [20] ATEX ETR or [21] Advanced ETR. If the alarm 166 ATEX ETR freq.lim.alarm is active, the output is 1.
[92]	ATEX ETR freq. warning	Selectable, if 1-90 Motor Thermal Protection is set to [20] ATEX ETR or [21] Advanced ETR. If the alarm 163 ATEX ETR cur.lim.warning is active, the output is 1.
[93]	ATEX ETR freq. alarm	Selectable, if 1-90 Motor Thermal Protection is set to [20] ATEX ETR or [21] Advanced ETR. If the warning 165 ATEX ETR freq.lim.warning is active, the output is 1.
[94]	RS Flipflop 0	See parameter group 13-1* Comparators
[95]	RS Flipflop 1	See parameter group 13-1* Comparators
[96]	RS Flipflop 2	See parameter group 13-1* Comparators
[97]	RS Flipflop 3	See parameter group 13-1* Comparators
[98]	RS Flipflop 4	See parameter group 13-1* Comparators
[99]	RS Flipflop 5	See parameter group 13-1* Comparators
[100]	RS Flipflop 6	See parameter group 13-1* Comparators
[101]	RS Flipflop 7	See parameter group 13-1* Comparators
[102]	Relay 1	
[103]	Relay 2	
[104]	Relay 3	X47/MCB 113
[105]	Relay 4	X47/MCB 113
[106]	Relay 5	X47/MCB 113
[107]	Relay 6	X47/MCB 113
[108]	Relay 7	X34/MCB 105
[109]	Relay 8	X34/MCB 105
[110]	Relay 9	X34/MCB 105

## Parameter Descriptions

6

13-52 SL Controller Action		
Array [20]		
Option:	Function:	
[0]	DISABLED	Select the action corresponding to the SLC event. Actions are executed when the corresponding event (defined in <i>parameter 13-51 SL Controller Event</i> ) is evaluated as true. The following actions are available for selection: [0] *DISABLED
[1]	No action	
[2]	Select set-up 1	Changes the active set-up ( <i>parameter 0-10 Active Set-up</i> ) to '1'. If the set-up is changed, it merges with other set-up commands coming from either the digital inputs or via a fieldbus.
[3]	Select set-up 2	Changes the active set-up ( <i>parameter 0-10 Active Set-up</i> ) to '2'. If the set-up is changed, it merges with other set-up commands coming from either the digital inputs or via a fieldbus.
[4]	Select set-up 3	Changes the active set-up ( <i>parameter 0-10 Active Set-up</i> ) to '3'. If the set-up is changed, it merges with other set-up commands coming from either the digital inputs or via a fieldbus.
[5]	Select set-up 4	Changes the active set-up ( <i>parameter 0-10 Active Set-up</i> ) to '4'. If the set-up is changed, it merges with other set-up commands coming from either the digital inputs or via a fieldbus.
[10]	Select preset ref 0	Selects preset reference 0. If the active preset reference is changed, it merges with other preset reference commands coming from either the digital inputs or via a fieldbus.
[11]	Select preset ref 1	Selects preset reference 1. If the active preset reference is changed, it merges with other preset reference commands coming from either the digital inputs or via a fieldbus.
[12]	Select preset ref 2	Selects preset reference 2. If the active preset reference is changed, it merges with other preset reference commands coming from either the digital inputs or via a fieldbus.
[13]	Select preset ref 3	Selects preset reference 3. If the active preset reference is changed, it merges with other preset reference commands coming from either the digital inputs or via a fieldbus.
[14]	Select preset ref 4	Selects preset reference 4.

13-52 SL Controller Action		
Array [20]		
Option:	Function:	
		If the active preset reference is changed, it merges with other preset reference commands coming from either the digital inputs or via a fieldbus.
[15]	Select preset ref 5	Selects preset reference 5. If the active preset reference is changed, it merges with other preset reference commands coming from either the digital inputs or via a fieldbus.
[16]	Select preset ref 6	Selects preset reference 6. If the active preset reference is changed, it merges with other preset reference commands coming from either the digital inputs or via a fieldbus.
[17]	Select preset ref 7	Selects preset reference 7. If the active preset reference is changed, it merges with other preset reference commands coming from either the digital inputs or via a fieldbus.
[18]	Select ramp 1	Selects ramp 1.
[19]	Select ramp 2	Selects ramp 2.
[20]	Select ramp 3	Selects ramp 3.
[21]	Select ramp 4	Selects ramp 4.
[22]	Run	Issues a start command to the frequency converter.
[23]	Run reverse	Issues a start reverse command to the frequency converter.
[24]	Stop	Issues a stop command to the frequency converter.
[25]	Qstop	Issues a quick stop command to the frequency converter.
[26]	Dcstop	Issues a DC stop command to the frequency converter.
[27]	Coast	The frequency converter coasts immediately. All stop commands including the coast command stop the SLC.
[28]	Freeze output	Freezes the output frequency of the frequency converter.
[29]	Start timer 0	Starts timer 0, see <i>parameter 13-20 SL Controller Timer</i> for further description.
[30]	Start timer 1	Starts timer 1, see <i>parameter 13-20 SL Controller Timer</i> for further description.
[31]	Start timer 2	Starts timer 2, see <i>parameter 13-20 SL Controller Timer</i> for further description.
[32]	Set digital out A low	Any output with SL output A is low.

## Parameter Descriptions

13-52 SL Controller Action		
Array [20]		
Option:	Function:	
[33]	Set digital out B low	Any output with SL output B is low.
[34]	Set digital out C low	Any output with SL output C is low.
[35]	Set digital out D low	Any output with SL output D is low.
[36]	Set digital out E low	Any output with SL output E is low.
[37]	Set digital out F low	Any output with SL output F is low.
[38]	Set digital out A high	Any output with SL output A is high.
[39]	Set digital out B high	Any output with SL output B is high.
[40]	Set digital out C high	Any output with SL output C is high.
[41]	Set digital out D high	Any output with SL output D is high.
[42]	Set digital out E high	Any output with SL output E is high.
[43]	Set digital out F high	Any output with SL output F is high.
[60]	Reset Counter A	Resets Counter A to zero.
[61]	Reset Counter B	Resets Counter B to zero.
[70]	Start timer 3	Start Timer 3, see <i>parameter 13-20 SL Controller Timer</i> for further description.
[71]	Start timer 4	Start Timer 4, see <i>parameter 13-20 SL Controller Timer</i> for further description.
[72]	Start timer 5	Start Timer 5, see <i>parameter 13-20 SL Controller Timer</i> for further description.
[73]	Start timer 6	Start Timer 6, see <i>parameter 13-20 SL Controller Timer</i> for further description.
[74]	Start timer 7	Start Timer 7, see <i>parameter 13-20 SL Controller Timer</i> for further description.

## 6.11 Parameters: 14-\*\* Special Functions

### 6.11.1 14-\*\* Special Functions

Parameter group for configuring special frequency converter functions.

### 6.11.2 14-0\* Inverter Switching

Parameters for configuring the inverter switching.

#### 14-03 Overmodulation

**Option: Function:**

[0]	Off	Connect the overmodulation function for the output voltage, to obtain an output voltage up to 15% greater than the mains voltage.
[1] *	On	No overmodulation of the output voltage, in order to avoid torque ripple on the motor shaft. This feature may be useful for applications such as grinding machines.

### 6.11.3 14-1\* Mains On/Off

Parameters for configuring mains failure monitoring and handling.

#### 14-12 Function at Mains Imbalance

**Option: Function:**

		Operation under severe main imbalance conditions reduces the lifetime of the motor. Conditions are considered severe if the motor is operated continuously near nominal load.
[0]	Trip	Trips the frequency converter
[1]	Warning	Issues a warning
[2]	Disabled	No action
[3] *	Derate	

### 6.11.4 14-2\* Trip Reset

Parameters for configuring auto reset handling, special trip handling and control card self test or initialisation.

#### 14-20 Reset Mode

**Option: Function:**

		Select the reset function after tripping. Once reset, the frequency converter can be restarted.
[0]	Manual reset	Performs a reset via [Reset] or via the digital inputs.
[10] *	Automatic reset x 10	Performs between one and twenty automatic resets after tripping.

### NOTICE

If the specified number of AUTOMATIC RESETs is reached within 10 minutes, the frequency converter enters [0] *Manual reset* mode. After the Manual reset is performed, the setting of 14-20 *Reset Mode* reverts to the original selection. If the number of AUTOMATIC RESETs is not reached within 10 minutes, or when a Manual reset is performed, the internal AUTOMATIC RESET counter returns to zero.

### CAUTION

The motor may start without warning.

#### Application Tip:

Since the default setting of the reset mode in the compressor drive is set up to auto-reset after 30 s this should be taken in consideration if a relay output is set to call for a service technician in case of an alarm. By setting 5-40 *Function Relay* to [9] *Alarm* and 5-41 *On Delay, Relay* to 40 s the relay will only activate at either a trip lock alarm or an alarm, which could not be auto-reset. Only the relay output can be used for this; the digital outputs do not have the On Delay feature.

#### 14-21 Automatic Restart Time

**Range: Function:**

30 s*	[0 - 600 s]	Enter the time interval from trip to start of the automatic reset function. This parameter is active when 14-20 <i>Reset Mode</i> is set to Automatic reset.
-------	-------------	--

#### 14-22 Operation Mode

**Option: Function:**

		Use this parameter to specify normal operation; to perform tests; or to initialise all parameters except 15-03 <i>Power Up's</i> , 15-04 <i>Over Temp's</i> and 15-05 <i>Over Volt's</i> . This function is active only when the power is cycled to the frequency converter.
[0] *	Normal operation	Normal operation of the frequency converter with the motor in the selected application.
[1]	Control card test	Tests the analog and digital inputs and outputs and the +10 V control voltage. The test requires a test connector with internal connections.  <b>Use the following procedure for the control card test:</b> <ol style="list-style-type: none"> <li>Select Control card test [1].</li> <li>Disconnect the mains supply and wait for the light in the display to go out.</li> <li>Set switches S201 (A53) and S202 (A54) = ON./I.</li> <li>Insert the test plug (see below).</li> <li>Connect to mains supply.</li> </ol>

## Parameter Descriptions

### 14-22 Operation Mode

**Option:**      **Function:**

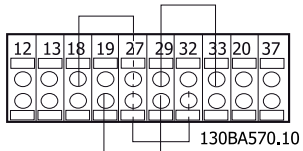
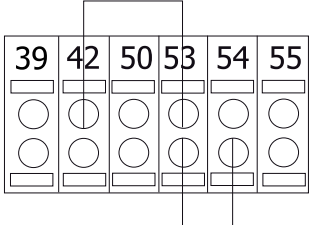
		<p>6. Carry out various tests.</p> <p>7. The results are displayed on the keypad and the frequency converter moves into an infinite loop.</p> <p>8. <i>14-20 Reset Mode</i> is automatically set to Normal operation. Carry out a power cycle to start up in Normal operation after a control card test.</p> <p><b>If the test is OK:</b> keypad read-out: Control Card OK. Disconnect the mains supply and remove the test plug. The green LED on the Control Card will light up.</p> <p><b>If the test fails:</b> keypad read-out: Control Card I/O failure. Replace the frequency converter or Control card. The red LED on the Control Card is turned on. Test plugs (connect the following terminals to each other): 18 - 27 - 32; 19 - 29 - 33; 42 - 53 - 54 1.</p> <div style="text-align: center;">  <p>130BA570.10</p> </div> <p><b>Illustration 6.20</b></p> <div style="text-align: center;">  <p>130BA571.10</p> </div> <p><b>Illustration 6.21</b></p>
[2]	Initialisation	Resets all parameter values to default settings, except for <i>15-03 Power Up's</i> , <i>15-04 Over Temp's</i> and <i>15-05 Over Volt's</i> . The frequency converter will reset during the next power-up. <i>14-20 Reset Mode</i> will also revert to the default setting [0] Normal operation.

### 14-52 Fan Control

**Option:**      **Function:**

		Select the minimum speed of the internal fan.
[0] *	Auto	Runs the fan only when the internal temperature of the frequency converter is in the range 35 °C . approx. 55 °C. The fan will run at low speed at 35 °C, and at full speed at approx. 55 °C.
[1]	On 50%	
[2]	On 75%	
[3]	On 100%	

### 14-53 Fan Monitor

**Option:**      **Function:**

		Select which reaction the frequency converter should take in case a fan fault is detected.
[0]	Disabled	
[1] *	Warning	
[2]	Trip	

### 14-60 Function at Over Temperature

**Option:**      **Function:**

		If either heatsink or control card temperature exceeds a factory-programmed temperature limit, a warning will be activated. If the temperature increases further, select whether the frequency converter should trip (trip locked) or derate the output current.
[0]	Trip	The frequency converter will trip (trip locked) and generate an alarm. Power must be cycled to reset the alarm, but will not allow restart of the motor until the heat sink temperature has dropped below the alarm limit.
[1] *	Derate	If the critical temperature is exceeded the output current will be reduced until the allowable temperature has been reached.

### 14-61 Function at Inverter Overload

**Option:**      **Function:**

		Is used in case of steady overload beyond the thermal limits (110% for 60 sec.).
[0]	Trip	The frequency converter trips and provides an alarm.
[1] *	Derate	Reduce pump speed to decrease the load on the power section and allowing this to cool down.

### 14-62 Inv. Overload Derate Current

**Range:**      **Function:**

95 %*	[50 - 100 %]	Defines the desired current level (in % of rated output current for the frequency converter) when running with reduced pump speed after load on the frequency converter has exceeded the allowable limit (110% for 60 s).
-------	--------------	---

6

## Parameter Descriptions

14-90 Fault Level	
Option:	Function:
[0] Off	Use this parameter to customize Fault levels. Use [0] Off with caution as it will ignore all Warnings & Alarms for the chosen source.
[1] Warning	
[2] Trip	
[3] Trip Lock	
[4] Trip w. delayed reset	

Failure	Alarm	Off	Warning	Trip	Trip Lock
Over Current	13			D	X
Motor phase missing	30			D	X
Motor phase missing	31			D	X
Motor phase missing	32			D	X

**Table 6.12 Table for Selection of Choice of Action when Selected Alarm Appears**

*D = Default setting. x = possible selection.*

*1) Only high power drives*

*In FC small and medium A69 is only a warning*

6

## Parameter Descriptions

### 6.12 Parameters: 15-\*\* Drive Information

#### 6.12.1 15-\*\* Drive Information

Parameter group containing compressor drive information such as

- operating data
- hardware configuration
- software versions

#### 6.12.2 15-0\* Operating data

Parameter group containing operating data, e.g. counters.

15-00 Operating hours		
Range:		Function:
0 h*	[0 - 2147483647 h]	View how many hours the frequency converter has run. The value is saved when the frequency converter is turned off.

15-01 Running Hours		
Range:		Function:
0 h*	[0 - 2147483647 h]	View how many hours the motor has run. Reset the counter in <i>15-07 Reset Running Hours Counter</i> . The value is saved when the frequency converter is turned off.

15-02 kWh Counter		
Range:		Function:
0 kWh*	[0 - 2147483647 kWh]	Registering the power consumption of the motor as a mean value over one hour. Reset the counter in <i>parameter 15-06 Reset kWh Counter</i> .

15-03 Power Up's		
Range:		Function:
0*	[0 - 2147483647 ]	View the number of times the frequency converter has been powered up.

15-04 Over Temp's		
Range:		Function:
0*	[0 - 65535 ]	View the number of frequency converter temperature faults which have occurred.

15-05 Over Volt's		
Range:		Function:
0*	[0 - 65535 ]	View the number of frequency converter overvoltages which have occurred.

15-06 Reset kWh Counter		
Option:		Function:
[0] *	Do not reset	No reset of the kWh counter is desired.
[1]	Reset counter	Press [OK] to reset the kWh counter to zero (see <i>parameter 15-02 kWh Counter</i> ).

### **NOTICE**

The reset is carried out by pressing [OK].

15-07 Reset Running Hours Counter		
Option:		Function:
[0] *	Do not reset	
[1]	Reset counter	Select <i>[1] Reset</i> and press [OK] to reset the Running Hours counter to zero (see <i>parameter 15-01 Running Hours</i> ). This parameter cannot be selected via the serial port, RS-485. Select <i>[0] Do not reset</i> if no reset of the Running Hours counter is desired.

15-08 Number of Starts		
Range:		Function:
	[0 - 4294967295]	View the total number of starts performed since power-on. The value is cleared to zero at power-up.

15-09 Number of Auto Resets		
Range:		Function:
	[0 - 4294967295]	View the total number of auto resets performed since power-on. The counter is cleared to zero at power-up.



## 6.13 Parameters: 16-\*\* Data Readouts

### 6.13.1 16-0\* General Status

16-00 Control Word		
Range:	Function:	
0*	[0 - 65535 ]	View the Control word sent from the frequency converter via the serial communication port in hex code.

16-01 Reference [Unit]		
Range:	Function:	
0 ReferenceFeed-backUnit*	[-999999 - 999999 ReferenceFeed-backUnit]	View the present reference value applied on impulse or analog basis in the unit resulting from the configuration selected in <i>1-00 Configuration Mode</i> (Hz, Nm, or RPM).

16-02 Reference [%]		
Range:	Function:	
0 %*	[-200 - 200 %]	View the total reference. The total reference is the sum of digital, analog, preset, bus, and freeze references, plus catch-up and slow-down.

16-03 Status Word		
Range:	Function:	
0*	[0 - 65535 ]	View the status word sent from the frequency converter via the serial communication port in hex code.

16-05 Main Actual Value [%]		
Range:	Function:	
0 %*	[-100 - 100 %]	View the 2-byte word sent with the status word to the Bus Master reporting the Main Actual Value.

16-09 Custom Readout		
Range:	Function:	
0 CustomReadoutUnit*	[0 - 0 CustomReadoutUnit]	View the value of custom readout from <i>parameter 0-30 Unit for User-defined Readout</i> to <i>parameter 0-32 Custom Readout Max Value</i>

### 6.13.2 16-1\* Motor Status

16-10 Power [kW]		
Range:	Function:	
0 kW*	[0 - 10000 kW]	Displays motor power in kW. The value shown is calculated based on the actual motor voltage and motor current. The value is filtered, and therefore approx. 30 ms may pass from when an input value changes to when the data readout values change. The resolution of readout value on fieldbus is in 10 W steps.

16-11 Power [hp]		
Range:	Function:	
0 hp*	[0 - 10000 hp]	View the motor power in hp. The value shown is calculated based on the actual motor voltage and motor current. The value is filtered, and therefore approximately 30 ms may pass from when an input value changes to when the data readout values change.

16-12 Motor Voltage		
Range:	Function:	
0 V*	[0 - 6000 V]	View the motor voltage, a calculated value used for controlling the motor.

16-13 Frequency		
Range:	Function:	
0 Hz*	[0 - 6500 Hz]	View the motor frequency, without resonance dampening.

16-14 Motor current		
Range:	Function:	
0 A*	[0 - 10000 A]	View the motor current measured as a mean value, $I_{RMS}$ . The value is filtered, and thus approximately 30 ms may pass from when an input value changes to when the data readout values change.

16-15 Frequency [%]		
Range:	Function:	
0 %*	[-100 - 100 %]	View a 2-byte word reporting the actual motor frequency (without resonance dampening) as a percentage (scale 0000-4000 Hex) of <i>4-19 Max Output Frequency</i> . Set <i>9-16 PCD Read Configuration</i> index 1 to send it with the status word instead of the MAV.

16-16 Torque [Nm]		
Range:	Function:	
0 Nm*	[-3000 - 3000 Nm]	View the torque value with sign, applied to the motor shaft. Linearity is not exact between 160% motor current and torque in relation to

## Parameter Descriptions

16-16 Torque [Nm]		
Range:	Function:	
		the rated torque. Some motors supply more than 160% torque. Consequently, the min. value and the max. value depend on the max. motor current as well as the motor used. The value is filtered, and thus approx. 30 ms may pass from when an input changes value to when the data readout values change.

16-17 Speed [RPM]		
Range:	Function:	
0 RPM*	[-30000 - 30000 RPM]	View the actual motor RPM. In open loop or closed loop process control, the motor RPM is estimated. In speed closed loop modes the motor RPM is measured.

16-18 Motor Thermal		
Range:	Function:	
0 %*	[0 - 100 %]	View the calculated thermal load on the motor. The cut-out limit is 100%. The basis for calculation is the ETR function selected in 1-90 Motor Thermal Protection.

16-19 KTY sensor temperature		
Range:	Function:	
0 °C*	[0 - 0 °C]	Returning the actual temperature on KTY sensor built into the motor. See parameter group 1-9* Motor Temperature.

16-20 Motor Angle		
Range:	Function:	
0*	[0 - 65535 ]	View the current encoder/resolver angle offset relative to the index position. The value range of 0-65535 corresponds to 0-2*pi (radians).

16-21 Torque [%] High Res.		
Range:	Function:	
0 %*	[-200 - 200 %]	The value shown is the torque in percent of nominal torque, with sign and 0.1% resolution, applied to the motor shaft.

16-22 Torque [%]		
Range:	Function:	
0 %*	[-200 - 200 %]	Value shown is the torque in percent of nominal torque, with sign, applied to the motor shaft.

16-25 Torque [Nm] High		
Range:	Function:	
0 Nm*	[-200000000 - 200000000 Nm]	View the torque value with sign, applied to the motor shaft. Some motors supply more than 160% torque. Consequently, the min. value and the max. value depend on the max. motor current as

16-25 Torque [Nm] High		
Range:	Function:	
		well as the motor used. This specific readout has been adapted to be able to show higher values than the standard readout in parameter 16-16 Torque [Nm].

### 6.13.3 16-3\* Drive Status

16-30 DC Link Voltage		
Range:	Function:	
0 V*	[0 - 10000 V]	View a measured value. The value is filtered with a 30 ms time constant.

16-32 Brake Energy /s		
Range:	Function:	
0 kW*	[0 - 10000 kW]	View the brake power transmitted to an external brake resistor, stated as an instantaneous value.

16-33 Brake Energy /2 min		
Range:	Function:	
0 kW*	[0 - 10000 kW]	View the brake power transmitted to an external brake resistor. The mean power is calculated on an average basis for the most recent 120 s.

16-34 Heatsink Temp.		
Range:	Function:	
0 °C*	[0 - 255 °C]	View the frequency converter heatsink temperature. The cut-out limit is 90 ±5 °C, and the motor cuts back in at 60 ±5 °C.

16-35 Inverter Thermal		
Range:	Function:	
0 %*	[0 - 100 %]	View the percentage load on the inverter.

16-36 Inv. Nom. Current		
Range:	Function:	
Size related*	[0.01 - 10000 A]	View the inverter nominal current, which must match the nameplate data on the connected motor. The data are used for calculation of torque, motor protection, etc.

16-37 Inv. Max. Current		
Range:	Function:	
Size related*	[0.01 - 10000 A]	View the inverter maximum current, which must match the nameplate data on the connected motor. The data are used for calculation of torque, motor protection, etc.

## Parameter Descriptions

6

16-38 SL Controller State		
Range:	Function:	
0* [0 - 100 ]	View the state of the event under execution by the SL controller.	

16-39 Control Card Temp.		
Range:	Function:	
0 °C* [0 - 100 °C]	View the temperature on the control card, stated in °C	

16-40 Logging Buffer Full		
Option:	Function:	
	View whether the logging buffer is full (see parameter group 15-1* <i>Data Log Settings</i> ). The logging buffer is never full when setting 15-13 <i>Logging Mode</i> to [0] <i>Log always</i> .	
[0] *	No	
[1]	Yes	

16-48 Speed Ref. After Ramp [RPM]		
Range:	Function:	
0 RPM* [-30000 - 30000 RPM]	This parameter specifies the reference given to the frequency converter after the speed ramp.	

### 6.13.4 16-5\* Ref. & Feedb.

16-50 External Reference		
Range:	Function:	
0* [-200 - 200 ]	View the total reference, the sum of digital, analog, preset, bus and freeze references, plus catch-up and slow-down.	

16-51 Pulse Reference		
Range:	Function:	
0* [-200 - 200 ]	View the reference value from programmed digital input(s). The readout can also reflect the impulses from an incremental encoder.	

16-52 Feedback[Unit]		
Range:	Function:	
0 ReferenceFeed-backUnit* [-999999.999 - 999999.999 ReferenceFeed-backUnit]	View the feedback unit resulting from the selection of unit and scaling in 3-00 <i>Reference Range</i> , 3-01 <i>Reference/Feedback Unit</i> , 3-02 <i>Minimum Reference</i> and 3-03 <i>Maximum Reference</i> .	

16-53 Digi Pot Reference		
Range:	Function:	
0* [-200 - 200 ]	View the contribution of the Digital Potentiometer to the actual reference.	

16-57 Feedback [RPM]		
Range:	Function:	
0 RPM* [-30000 - 30000 RPM]	Readout parameter where the actual motor RPM from the feedback source can be read in both closed loop and open loop. Select the feedback source in 7-00 <i>Speed PID Feedback Source</i> .	

### 6.13.5 16-6\* Inputs and Outputs

16-60 Digital Input		
Range:	Function:	
0* [0 - 1023 ]	View the signal states from the active digital inputs. Example: Input 18 corresponds to bit no. 5, '0' = no signal, '1' = connected signal. Bit 6 works in the opposite way, on = '0', off = '1' (safe stop input).	
	Bit 0	Digital input term. 33
	Bit 1	Digital input term. 32
	Bit 2	Digital input term. 29
	Bit 3	Digital input term. 27
	Bit 4	Digital input term. 19
	Bit 5	Digital input term. 18
	Bit 6	Digital input term. 37
	Bit 7	Digital input GP I/O term. X30/4
	Bit 8	Digital input GP I/O term. X30/3
	Bit 9	Digital input GP I/O term. X30/2
	Bit 10-63	Reserved for future terminals

Table 6.13 Active Digital Inputs

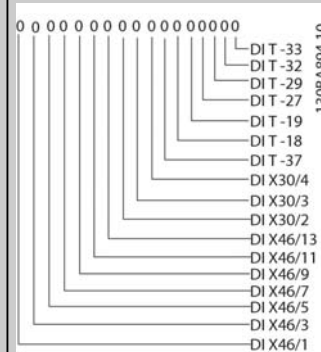

Illustration 6.22 Relay Settings

## Parameter Descriptions

16-61 Terminal 53 Switch Setting		
Option:	Function:	
		View the setting of input terminal 53.
[0] *	Current	
[1]	Voltage	

16-62 Analog Input 53		
Range:	Function:	
0*	[-20 - 20 ]	View the actual value at input 53.

16-63 Terminal 54 Switch Setting		
Option:	Function:	
		View the setting of input terminal 54.
[0] *	Current	
[1]	Voltage	

16-64 Analog Input 54		
Range:	Function:	
0*	[-20 - 20 ]	View the actual value at input 54.

16-65 Analog Output 42 [mA]		
Range:	Function:	
0*	[0 - 30 ]	View the actual value at output 42 in mA. The value shown reflects the selection in 6-50 Terminal 42 Output.

16-66 Digital Output [bin]		
Range:	Function:	
0*	[0 - 15 ]	View the binary value of all digital outputs.

16-68 Freq. Input #33 [Hz]		
Range:	Function:	
0*	[0 - 130000 ]	View the actual value of the frequency applied at terminal 33 as an impulse input.

16-69 Pulse Output #27 [Hz]		
Range:	Function:	
0*	[0 - 40000 ]	View the actual value of pulses applied to terminal 27 in digital output mode.

16-70 Pulse Output #29 [Hz]		
Range:	Function:	
0 *	[0 - 40000 ]	View the actual value of pulses at terminal 29 in digital output mode.

16-71 Relay Output [bin]		
Range:	Function:	
0*	[0 - 511 ]	View the settings of all relays.

Readout choice (Par. 16-71):  
Relay output (bin):

130BA195.10

0 0 0 0 bin

OptionB card relay 09  
OptionB card relay 08  
OptionB card relay 07  
Power card relay 02  
Power card relay 01

**Illustration 6.24 Relay Settings**

16-72 Counter A		
Range:	Function:	
0*	[-2147483648 - 2147483647 ]	View the present value of Counter A. Counters are useful as comparator operands, see <i>parameter 13-10 Comparator Operand</i> . The value can be reset or changed either via digital inputs (parameter group 5-1* <i>Digital Inputs</i> ) or by using an SLC action ( <i>parameter 13-52 SL Controller Action</i> ).

16-73 Counter B		
Range:	Function:	
0*	[-2147483648 - 2147483647 ]	View the present value of Counter B. Counters are useful as comparator operands ( <i>parameter 13-10 Comparator Operand</i> ). The value can be reset or changed either via digital inputs (parameter group 5-1* <i>Digital Inputs</i> ) or by using an SLC action ( <i>parameter 13-52 SL Controller Action</i> ).

16-74 Prec. Stop Counter		
Range:	Function:	
0*	[0 - 2147483647 ]	Returns the actual counter value of precise counter ( <i>1-84 Precise Stop Counter Value</i> ).

### 6.13.6 16-8\* Fieldbus & FC Port

Parameters for reporting the BUS references and control words.

16-80 Fieldbus CTW 1		
Range:	Function:	
0* [0 - 65535 ]	View the 2-byte control word (CTW) received from the bus master. Interpretation of the control word depends on the fieldbus option installed and the control word profile selected in <i>8-10 Control Profile</i> . For more information, refer to the relevant fieldbus manual.	

16-82 Fieldbus REF 1		
Range:	Function:	
0* [-200 - 200 ]	View the 2-byte word sent with the control word from the bus master to set the reference value. For more information, refer to the relevant fieldbus manual.	

16-84 Comm. Option STW		
Range:	Function:	
0* [0 - 65535 ]	View the extended fieldbus comm. option status word. For more information, refer to the relevant fieldbus manual.	

16-85 FC Port CTW 1		
Range:	Function:	
0* [0 - 65535 ]	View the 2-byte control word (CTW) received from the bus master. Interpretation of the control word depends on the fieldbus option installed and the control word profile selected in <i>8-10 Control Profile</i> .	

16-86 FC Port REF 1		
Range:	Function:	
0* [-200 - 200 ]	View the 2-byte status word (STW) sent to the bus master. Interpretation of the status word depends on the fieldbus option installed and the control word profile selected in <i>8-10 Control Profile</i> .	

### 6.13.7 16-9\* Diagnosis Read-Outs

#### **NOTICE**

When using Trane Drive Utility (TDU), the readout parameters can only be read online, i.e. as the actual status. This means that the status is not stored in the Trane Drive Utility (TDU) file.

16-90 Alarm Word		
Range:	Function:	
0* [0 - 4294967295 ]	View the alarm word sent via the serial communication port in hex code.	

16-91 Alarm Word 2		
Range:	Function:	
0* [0 - 4294967295 ]	View the alarm word sent via the serial communication port in hex code.	

16-92 Warning Word		
Range:	Function:	
0* [0 - 4294967295 ]	View the warning word sent via the serial communication port in hex code.	

16-93 Warning Word 2		
Range:	Function:	
0* [0 - 4294967295 ]	View the warning word sent via the serial communication port in hex code.	

16-94 Ext. Status Word		
Range:	Function:	
0* [0 - 4294967295 ]	Returns the extended warning word sent via the serial communication port in hex code.	

16-95 Ext. Status Word 2		
Range:	Function:	
0* [0 - 4294967295 ]	Returns the extended warning word 2 sent via the serial communication port in hex code.	

### 6.14 Parameters: 25-\*\* Cascade Controller

Parameters for configuring the Basic Cascade Controller for sequence control of multiple compressors.

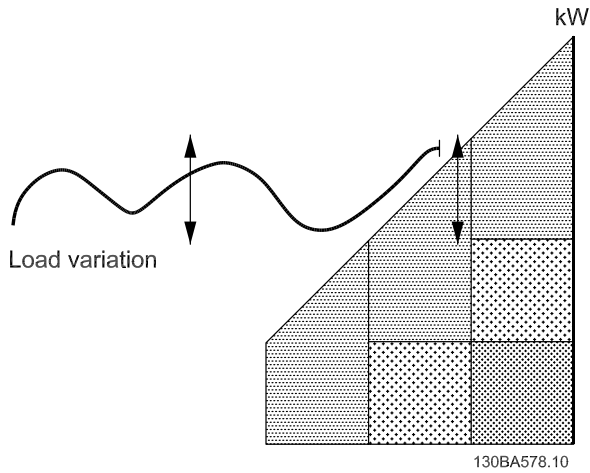

Illustration 6.25 Cascade Controller Feedback Signals

To configure the Cascade Controller to the actual system and the desired control strategy, it is recommended to follow the below sequence, starting with parameter group 25-0\* *System Settings*, and next parameter group 25-5\* *Alternation Settings*. These parameters can normally be set in advance.

Parameters in parameter group 25-2\* *Bandwidth Settings* and 25-4\* *Staging settings* will often be dependent on the dynamic of the system and final adjustment to be done at the commissioning of the plant.

**NOTICE**

The Cascade Controller is supposed to operate in closed loop controlled by the built-in PI controller ([1] *Speed Closed Loop* selected in 1-00 *Configuration Mode*). If [0] *Speed Open Loop* is selected in 1-00 *Configuration Mode*, all fixed speed compressors will be destaged, but the variable speed compressor will still be controlled by the frequency converter, now as an open loop configuration:

6

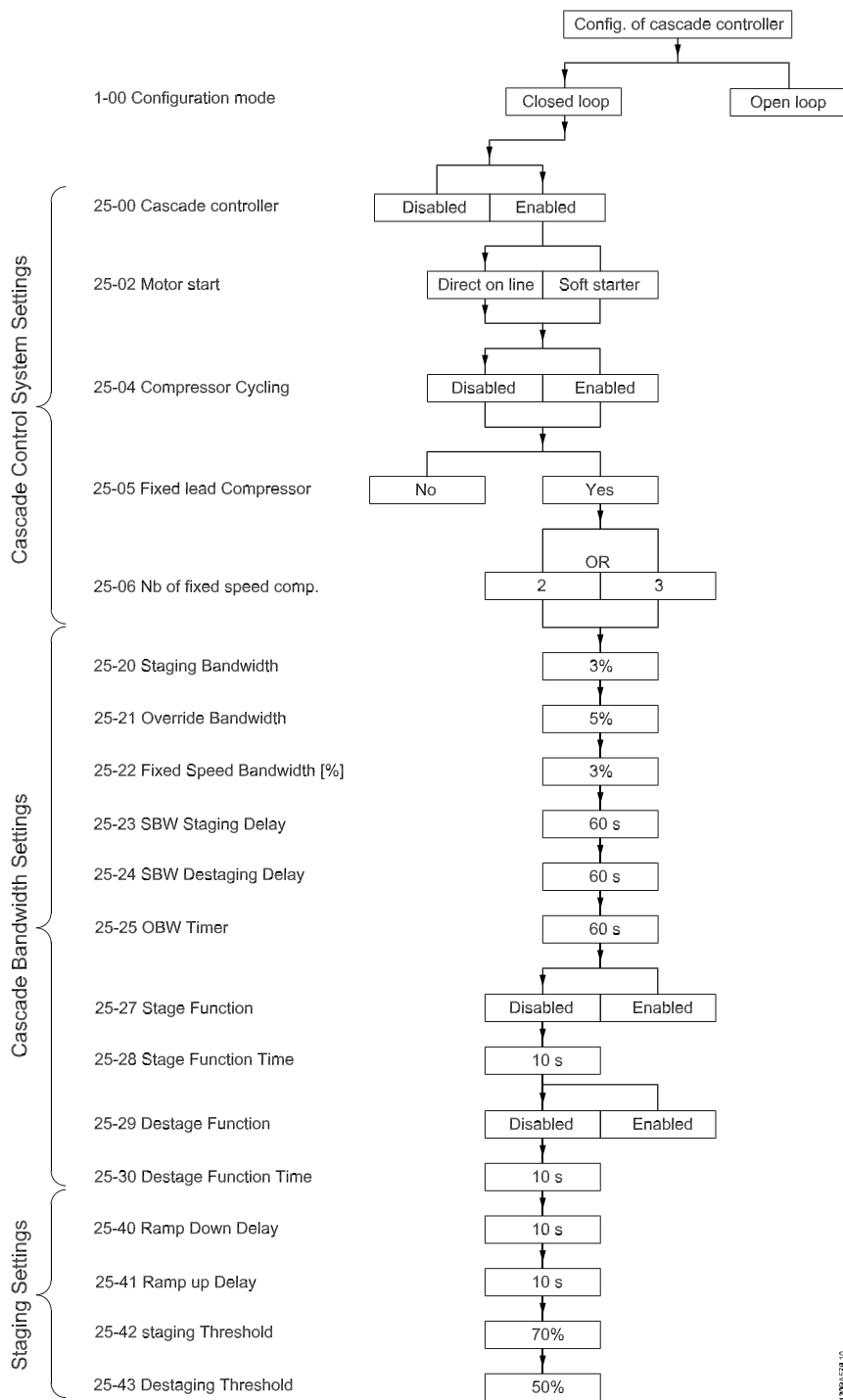

130045751 10

Illustration 6.26 Configuring the Cascade Controller

## Parameter Descriptions

### 6.14.1 25-0\* System Settings

Parameters related to control principles and configuration of the system.

#### 25-00 Cascade Controller

**Option:            Function:**

		For operation of multiple devices (compressor) systems where capacity is adapted to actual load by means of speed control combined with on/off control of the devices. For simplicity only compressor systems are described.
[0]	Disabled *	The Cascade Controller is not active. All built-in relays assigned to compressor motors in the cascade function will be de-energized. If a variable speed compressor is connected to the frequency converter directly (not controlled by a built-in relay), this compressor will be controlled as a single compressor system.
[1]	Enabled	The Cascade Controller is active and will stage/destage compressors according to load on the system.

#### **NOTICE**

This parameter can only be [1] Enabled, if 22-75 Short Cycle Protection is set to [0] Disabled.

#### 25-02 Motor Start

**Option:            Function:**

		Motors are connected to the mains directly with a contactor or with a soft starter. When the value of 25-02 Motor Start is set to an option other than [0] Direct on Line, then 25-50 Lead Compressor Alternation is automatically set to the default of [0] Direct on Line.
[0] *	Direct on Line	Each fixed speed compressor is connected to line directly via a contactor.
[1]	Soft starter	Each fixed speed compressor is connected to line via a soft starter.

#### 25-04 Compressor Cycling

**Option:            Function:**

		To provide equal hours of operation with fixed speed compressors, the compressor use can be cycled. The selection of compressor cycling is either "first in – last out" or equal running hours for each compressor.
[0] *	Disabled	The fixed speed compressors will be connected in the order 1 – 2 – 3 and disconnected in the order 3 – 2 – 1. (First in – last out)
[1]	Enabled	The fixed speed compressors will be connected/disconnected to have equal running hours for each compressor.

#### 25-05 Fixed Lead Compressor

**Option:            Function:**

		Fixed Lead Compressor means that the variable speed compressor is connected directly to the frequency converter and if a contactor is applied between frequency converter and compressor, this contactor will not be controlled by the frequency converter.
[0]	No	The lead compressor function can alternate between the compressors controlled by the two built in relays. One compressor must be connected to the built-in RELAY 1, and the other compressor to RELAY 2. The compressor function (Cascade Compressor1 and Cascade Compressor2) will automatically be assigned to the relays (maximum two compressors can in this case be controlled from the frequency converter).
[1] *	Yes	The lead compressor will be fixed (no alternation) and connected directly to the frequency converter. The 25-50 Lead Compressor Alternation is automatically set to [0] Off. Built-in relays Relay 1 and Relay 2 can be assigned to separate fixed speed compressors. In total three compressors can be controlled by the frequency converter.

#### 25-06 Number of Compressors

**Option:            Function:**

		The number of compressors connected to the Cascade Controller including the variable speed compressor. If the variable speed compressor is connected directly to the frequency converter and the other fixed speed compressors (lag compressors) are controlled by the two built in relays, three compressors can be controlled. If both the variable speed and fixed speed compressors are to be controlled by built-in relays, only two compressors can be connected.
[0] *	2 compressors	If 25-05 Fixed Lead Compressor is set to [0] No: one variable speed compressor and one fixed speed compressor; both controlled by built in relay. If 25-05 Fixed Lead Compressor is set to [1] Yes: one variable speed compressor and one fixed speed compressor controlled by built-in relay
[1]	3 compressors	[1] 3 Compressors: One lead compressor, see 25-05 Fixed Lead Compressor. Two fixed speed compressors controlled by built-in relays.



## Parameter Descriptions

### 6.14.2 25-2\* Bandwidth Manager

Parameters for setting the bandwidth within which the pressure/temperature will be allowed to operate before staging/destaging fixed speed compressors. Also includes various timers to stabilize the control.

#### 25-20 Staging Bandwidth [%]

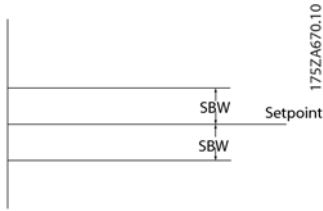
Range:	Function:
10%* [1 - 100 %]	<p>Set the staging bandwidth (SBW) percentage to accommodate normal system pressure fluctuation. In cascade control systems, to avoid frequent switching of fixed speed compressors, the desired system pressure is typically kept within a bandwidth rather than at a constant level.</p> <p>The SBW is programmed as a percentage of the numerically larger value of <i>3-03 Maximum Reference</i> and <i>3-02 Minimum Reference</i>. For example, if <i>3-03 Maximum Reference</i> is 10 bar and the SBW is set at 10%, a system pressure between 4.0 and 6.0 bar is tolerated if the setpoint is 5 bar. No staging or destaging will occur within this bandwidth.</p>  <p><b>Illustration 6.27 Staging Bandwidth</b></p>

#### 25-21 Override Bandwidth [%]

Range:	Function:
100% = Disabled*	<p>When a large and quick change in the system demand occurs, the system pressure rapidly changes and an immediate staging or destaging of a fixed speed compressor becomes necessary to match the requirement. The override bandwidth (OBW) is programmed to override the staging/destaging timer (<i>25-23 SBW Staging Delay/25-24 SBW Destaging Delay</i>) for immediate response. The OBW must always be programmed to a higher value than the value set in <i>25-20 Staging Bandwidth (SBW)</i>. The OBW is a percentage of <i>3-03 Maximum Reference</i>.</p>

#### 25-21 Override Bandwidth [%]

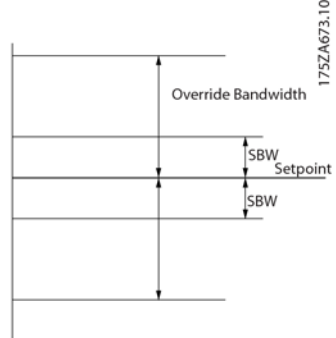
Range:	Function:
	 <p><b>Illustration 6.28 Override Bandwidth</b></p> <p>Setting the OBW too close to the SBW could defeat the purpose with frequent staging at momentary pressure changes. Setting the OBW too high might lead to unacceptably high or low pressure in the system while the SBW timers are running. The value can be optimized with increased familiarity with the system. See <i>25-25 OBW Time</i>.</p> <p>To avoid unintended staging during the commissioning phase and fine tuning of the controller, initially leave the OBW at the factory setting of 100% (Off). When the fine tuning is completed, the OBW should be set to the desired value. An initial value of 10% is suggested.</p>

#### 25-22 Fixed Speed Bandwidth [%]

Range:	Function:
10%* [1 - 100%]	<p>When the cascade control system is running normally and the frequency converter issues a trip alarm, it is important to maintain the system head. The Cascade Controller does this by continuing to stage/destage the fixed speed compressor on and off. Due to the fact that keeping the head at the setpoint would require frequent staging and destaging when only a fixed speed compressor is running, a wider Fixed Speed Bandwidth (FSBW) is used instead of SBW. It is possible to stop the fixed speed compressors, in case of an alarm situation, by pressing the [Off] or [Hand On] or if the signal programmed for Start on digital input goes low. In case the issued alarm is a trip-lock alarm then the Cascade Controller must stop the system immediately by cutting out all the fixed speed compressors. This is basically the same as Emergency Stop (Coast/Coast inverse Command) for the Cascade Controller.</p>

## Parameter Descriptions

### 25-23 SBW Staging Delay

**Range:** [0-3000 sec.]

**Function:**

60 sec.*	[0-3000 sec.]	<p>Immediate staging of a fixed speed compressor is not desirable when a momentary pressure drop in the system exceeds the Staging Bandwidth (SBW). Staging is delayed by the length of time programmed. If the pressure increases to within the SBW before the timer has elapsed, the timer is reset.</p> <p style="text-align: center;"><b>Illustration 6.29 SBW Staging Delay</b></p>
----------	---------------	--

### 25-24 SBW Destaging Delay

**Range:** [0-3000 sec.]

**Function:**

60 sec.*	[0-3000 sec.]	<p>Immediate destaging of a fixed speed compressor is not desirable when a momentary pressure increase in the system that exceeds the Staging Bandwidth (SBW). Destaging is delayed by the length of time programmed. If the pressure decreases to within the SBW before the timer has elapsed, the timer is reset.</p> <p style="text-align: center;"><b>Illustration 6.30 SBW Destaging Delay</b></p>
----------	---------------	---

### 25-25 OBW Time

**Range:** [0 – 300 sec.]

**Function:**

60 sec.*	[0 – 300 sec.]	<p>Staging a fixed speed compressor creates a momentary pressure peak in the system, which might exceed the Override Bandwidth (OBW). It is not desirable to destage a compressor in response to a staging pressure peak. The OBW Time can be programmed to prevent staging until the system pressure has stabilized and normal control established. Set the timer to a value that allows the system to stabilize after staging. The 10 second factory setting is appropriate in most applications. In highly dynamic systems, a shorter time may be desirable.</p> <p style="text-align: center;"><b>Illustration 6.31 OBW Time</b></p>
----------	----------------	--

### 25-27 Stage Function

**Option:** [0] \* Disabled

**Function:**

[0] *	Disabled	
[1]	Enabled	If the Stage Function is set to [0] Disabled, 25-28 Stage Function Time will not be activated.

### 25-28 Stage Function Time

**Range:** [0 – 300 sec.]

**Function:**

10 sec.*	[0 – 300 sec.]	<p>The Stage Function Time is programmed to avoid frequent staging of the fixed speed compressors. The Stage Function Time starts if it is [1] Enabled by 25-27 Stage Function and when the variable speed compressor is running at 4-13 Motor Speed High Limit [RPM] or 4-14 Motor Speed High Limit [Hz] (or at 4-11 Motor Speed Low Limit [RPM] or 4-12 Motor Speed Low Limit [Hz] if 7-30 Process PID Normal/Inverse Control is programmed to Inverse), with at least one fixed speed compressor in the stop position. When the programmed value of the timer expires, a fixed speed compressor is staged.</p>
----------	----------------	---

## Parameter Descriptions

### 25-29 Destage Function

**Option:**      **Function:**

[0] *	Disabled	
[1]	Enabled	The Destage Function ensures that the lowest numbers of compressors are running to save energy. If the Destage Function is set to [0] <i>Disabled</i> , the 25-30 <i>Destage Function Time</i> will not be activated.

### 25-30 Destage Function Time

**Range:**      **Function:**

10 sec.*	[0 – 300 sec.]	<p>The Destage Function Timer is programmable to avoid frequent staging/destaging of the fixed speed compressors. The Destage Function Time starts when the adjustable speed compressor is running at 4-11 <i>Motor Speed Low Limit [RPM]</i> or 4-12 <i>Motor Speed Low Limit [Hz]</i> (or at 4-13 <i>Motor Speed High Limit [RPM]</i> or 4-14 <i>Motor Speed High Limit [Hz]</i> if 7-30 <i>Process PID Normal/ Inverse Control</i> is programmed to Inverse), with one or more fixed speed compressors in operation and system requirements satisfied. In this situation, the adjustable speed compressor contributes little to the system. When the programmed value of the timer expires, a stage is removed.</p>
----------	----------------	--

Illustration 6.32 Destage Function Time

### 6.14.3 25-4\* Staging Settings

Parameters determining conditions for staging/destaging the compressors.

### 25-40 Ramp Down Delay

**Range:**      **Function:**

10 sec.*	[0 – 120 sec.]	<p>When adding a fixed speed compressor controlled by a soft starter, it is possible to delay the ramp down of the lead compressor until a preset time after the start of the fixed speed compressor to eliminate pressure surges in the system.</p> <p>Only to be used if [1] <i>Soft Starter</i> is selected in 25-02 <i>Motor Start</i>.</p>
----------	----------------	---

### 25-41 Ramp Up Delay

**Range:**      **Function:**

10 sec.*	[0 – 120 sec.]	<p>When removing a fixed speed compressor controlled by a soft starter, it is possible to delay the ramp up of the lead compressor until a preset time after the stopping of the fixed speed compressor to eliminate pressure surges in the system.</p> <p>Only to be used if [1] <i>Soft Starter</i> is selected in 25-02 <i>Motor Start</i>.</p>
----------	----------------	--

Illustration 6.33 Ramp-up Delay

### 25-42 Staging Threshold

**Range:**      **Function:**

90%*	[0 – 100%]	<p>When adding a fixed speed compressor, in order to prevent an overshoot of pressure, the variable speed compressor ramps down to a lower speed. When the variable speed compressor reaches the "Staging Speed" the fixed speed compressor is staged on. The Staging Threshold is used to calculate the speed of the variable speed compressor when the "cut-in point" of the fixed speed compressor occurs. The calculation of the Staging Threshold is the ratio of 4-11 <i>Motor Speed Low Limit [RPM]</i> or 4-12 <i>Motor Speed Low Limit [Hz]</i> to 4-13 <i>Motor Speed High Limit [RPM]</i> or 4-14 <i>Motor Speed High Limit [Hz]</i> expressed in percent. Staging Threshold must range from</p> $\eta_{STAGE\%} = \frac{n_{LOW}}{n_{HIGH}} \times 100\%$ <p>to 100%, where <math>n_{LOW}</math> is Motor Speed Low Limit and <math>n_{HIGH}</math> is Motor Speed High Limit.</p>
------	------------	---

Illustration 6.34 Staging Threshold

### 25-43 Destaging Threshold

**Range:**      **Function:**

50%*	[0 – 100%]	<p>When removing a fixed speed compressor, in order to prevent an undershoot of pressure, the variable speed compressor ramps up to a higher</p>
------	------------	--

## Parameter Descriptions

### 25-43 Destaging Threshold

**Range:**      **Function:**

speed. When the variable speed compressor reaches the "Destaging Speed" the fixed speed compressor is destaged. The Destaging Threshold is used to calculate the speed of the variable speed compressor when the destaging of the fixed speed compressor occurs. The calculation of the Destaging Threshold is the ratio of 4-11 Motor Speed Low Limit [RPM] or 4-12 Motor Speed Low Limit [Hz] to 4-13 Motor Speed High Limit [RPM] or 4-14 Motor Speed High Limit [Hz] expressed in percent.

Destaging Threshold must range from

$$\eta_{STAGE\%} = \frac{\eta_{LOW}}{\eta_{HIGH}} \times 100\%$$

to 100%, where  $\eta_{LOW}$  is Motor Speed Low Limit and  $\eta_{HIGH}$  is Motor Speed High Limit.

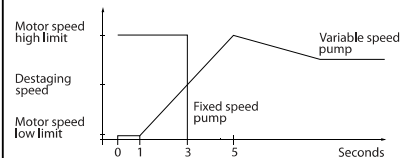

Illustration 6.35 Destaging Threshold

1308A367.10

### 25-44 Staging Speed [RPM]

**Option:**      **Function:**

0 N/A Readout of the below calculated value for Staging Speed. When adding a fixed speed compressor, in order to prevent an overshoot of pressure, the variable speed compressor ramps down to a lower speed. When the variable speed compressor reaches the "Staging Speed" the fixed speed compressor is staged on. Staging Speed calculation is based on 25-42 Staging Threshold and 4-13 Motor Speed High Limit [RPM].

Staging Speed is calculated with the following formula:

$$\eta_{STAGE} = \eta_{HIGH} \frac{\eta_{STAGE\%}}{100}$$

where  $\eta_{HIGH}$  is Motor Speed High Limit and  $\eta_{STAGE100\%}$  is the value of Staging Threshold.

### 25-45 Staging Speed [Hz]

**Option:**      **Function:**

0 N/A Readout of the below calculated value for Staging Speed. When adding a fixed speed compressor, in order to prevent an overshoot of pressure, the variable speed compressor ramps down to a lower speed. When the variable speed compressor reaches the "Staging Speed" the fixed speed compressor is staged on. Staging Speed calculation is based on 25-42 Staging Threshold and 4-14 Motor Speed High Limit [Hz].

Staging Speed is calculated with the following formula:

### 25-45 Staging Speed [Hz]

**Option:**      **Function:**

$\eta_{STAGE} = \eta_{HIGH} \frac{\eta_{STAGE\%}}{100}$  where  $\eta_{HIGH}$  is Motor Speed High Limit and  $\eta_{STAGE100\%}$  is the value of Staging Threshold.

### 25-46 Destaging Speed [RPM]

**Option:**      **Function:**

0 N/A Readout of the below calculated value for Destaging Speed. When removing a fixed speed compressor, in order to prevent an undershoot of pressure, the variable speed compressor ramps up to a higher speed. When the variable speed compressor reaches the "Destaging Speed" the fixed speed compressor is destaged. Destaging Speed is calculated based on 25-43 Destaging Threshold and 4-13 Motor Speed High Limit [RPM].

Destaging Speed is calculated with the following formula:

$$\eta_{DESTAGE} = \eta_{HIGH} \frac{\eta_{DESTAGE\%}}{100}$$

where  $\eta_{HIGH}$  is Motor Speed High Limit and  $\eta_{DESTAGE100\%}$  is the value of Destaging Threshold.

### 25-47 Destaging Speed [Hz]

**Option:**      **Function:**

Readout of the below calculated value for Destaging Speed. When removing a fixed speed compressor, in order to prevent an undershoot of pressure, the variable speed compressor ramps up to a higher speed. When the variable speed compressor reaches the "Destaging Speed" the fixed speed compressor is destaged. Destaging Speed is calculated based on 25-43 Destaging Threshold and 4-14 Motor Speed High Limit [Hz].

Destaging Speed is calculated with the following formula:

$$\eta_{DESTAGE} = \eta_{HIGH} \frac{\eta_{DESTAGE\%}}{100}$$

where  $\eta_{HIGH}$  is Motor Speed High Limit and  $\eta_{DESTAGE100\%}$  is the value of Destaging Threshold.

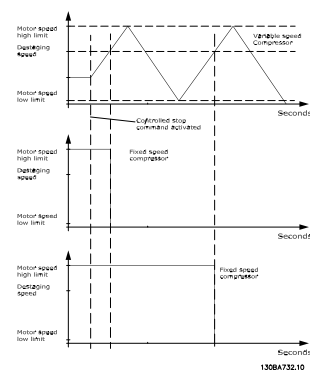

Illustration 6.36 Destaging Speed

1308A732.10

## Parameter Descriptions

### 6.14.4 25-5\* Alternation Settings

Parameters for defining the conditions for alternation of the variable speed compressor (lead), if selected as part of the control strategy.

#### 25-50 Lead Compressor Alternation

Option:	Function:
	Lead compressor alternation equalizes the use of compressors by periodically changing the compressor that is speed controlled. This ensures that compressors are equally used over time. Alternation equalizes the usage of compressors by always choosing the compressor with the lowest number of used hours to stage on next.
[0] * Off	No alternation of lead compressor function will take place. It is not possible to set this parameter to options other than [0] Off if 25-02 Motor Start is set other than [0] Direct on Line. <b>NOTICE</b> It is not possible to select other than [0] Off if 25-05 Fixed Lead Compressor is set to [1] Yes.
[1] At Staging	Alternation of the lead compressor function will take place when staging another compressor.
[2] At Command	Alternation of the lead compressor function will take place at an external command signal or a pre-programmed event. See 25-51 Alternation Event for available options.
[3] At Staging or at Command	Alternation of the variable speed (lead) compressor will take place at staging or the "At Command" signal (See above).

#### 25-51 Alternation Event

Option:	Function:
	This parameter is only active if the options [2] At Command or [3] At Staging or Command have been selected in 25-50 Lead Compressor Alternation. If an Alternation Event is selected, the alternation of lead compressor takes place every time the event occurs.
[0] * External	Takes place when a signal is applied to one of the digital inputs on the terminal strip and this input has been assigned to [121] Lead Compressor Alternation in parameter group 5-1* Digital Inputs.
[1] Alternation Time Interval	Takes place every time 25-52 Alternation Time Interval expires.

#### 25-52 Alternation Time Interval

Range:	Function:
24 h* [1 – 999 h]	If [1] Alternation Time Interval option in 25-51 Alternation Event is selected, the alternation of the variable speed compressor takes place every time the Alternation Time Interval expires (can be checked out in 25-53 Alternation Timer Value).

#### 25-53 Alternation Time Value

Option:	Function:
0 N/A	Readout parameter for the Alternation Time Interval value set in 25-52 Alternation Time Interval.

#### 25-55 Alternation if Capacity < 50%

Option:	Function:
[0] Disabled	
[1] * Enabled	If Alternation If Capacity <50% is enabled, the compressor alternation can only occur if the capacity is equal to or below 50%. The capacity calculation is the ratio of running compressors (including the variable speed compressor) to the total number of available compressors (including variable speed compressor, but not those interlocked). $\text{Capacity} = \frac{N_{\text{Running}}}{N_{\text{Total}}} \times 100\%$ For the Basic Cascade Controller all compressors are equal size. <i>Disabled</i> [0]: The lead compressor alternation will take place at any compressor capacity. <i>Enabled</i> [1]: The lead compressor function will be alternated only if the numbers of compressors running are providing less than 50% of total compressor capacity. Only valid if 25-50 Lead Compressor Alternation is different from [0] Off.

#### 25-56 Staging Mode at Alternation

Option:	Function:
	This parameter is only active if the option selected in 25-50 Lead Compressor Alternation is different from [0] Off. Two types of staging and destaging of compressors are possible. Slow transfer makes staging and destaging smooth. Quick Transfer makes staging and destaging as fast as possible; the variable speed compressor is just cut out (coasted).
[0] * Slow	At alternation, the variable speed compressor is ramped up to maximum speed and then ramped down to a standstill.
[1] Quick	At alternation, the variable speed compressor is ramped up to maximum speed and then coasted to standstill.

Illustration 6.37 is an example of the Slow transfer staging. The variable speed compressor (top graph) and one fixed

## Parameter Descriptions

speed compressor (bottom graph) are running before the staging command. When the [0] Slow transfer command is activated, an alternation is carried out by ramping the variable speed compressor to 4-13 Motor Speed High Limit [RPM] or 4-14 Motor Speed High Limit [Hz], and then decelerated to zero speed. After a "Delay Before Starting Next Compressor" (25-58 Run Next Compressor Delay) the next lead compressor (middle graph) is accelerated and another original lead compressor (top graph) is added after the "Delay Before Running On Mains" (25-59 Run on Mains Delay) as a fixed speed compressor. The next lead compressor (middle graph) is decelerated to Motor Speed Low Limit and then allowed to vary speed to maintain system pressure.

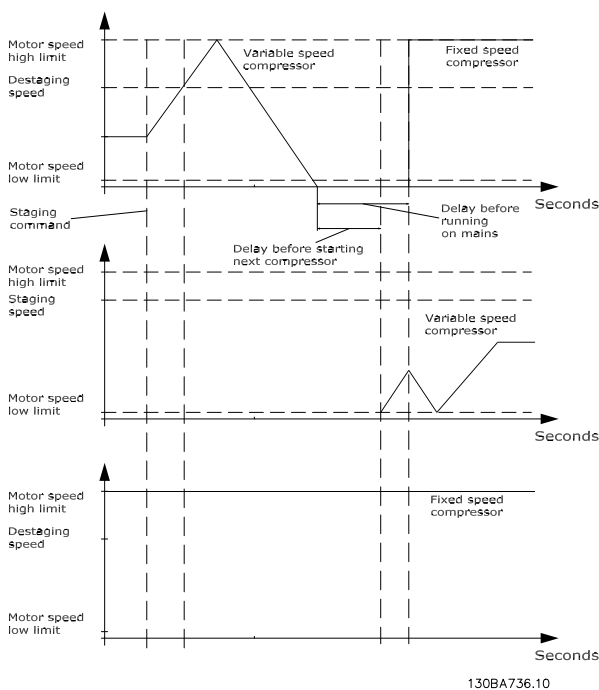

Illustration 6.37 Slow Transfer Staging

### 25-58 Run Next Compressor Delay

Range:	Function:
0.5 sec* [25-58 Run Next Compressor Delay – 5.0 sec]	This parameter is only active if the option selected in 25-50 Lead Compressor Alternation, is different from [0] Off. This parameter sets the time between stopping the old variable speed compressor and starting another compressor as a new variable speed compressor. Refer to 25-56 Staging Mode at Alternation and Illustration 6.37 for description of staging and alternation.

### 25-59 Run on Mains Delay

Range:	Function:
0.5 sec* [25-58 Run Next Compressor Delay – 5.0 sec]	This parameter is only active if the option selected in 25-50 Lead Compressor Alternation, is different from [0] Off. This parameter sets the time between stopping the old variable speed compressor and starting this compressor as a new fixed speed compressor. Refer to 25-56 Staging Mode at Alternation and Illustration 6.37 for description of staging and alternation.

## 6.14.5 25-8\* Status

Readout parameters informing about the operating status of the cascade controller and the compressors controlled.

### 25-80 Pack Status

Option:	Function:
	Read out of the status of the Pack Controller.
Disabled	Pack Controller is disabled (25-00 Cascade Controller).
Emergency	All compressors have been stopped by means of a Coast/Coast inverse or an External Interlock command applied to the frequency converter.
Off	All compressors have been stopped by means of a Stop command applied to the frequency converter.
In Open Loop	1-00 Configuration Mode has been set for [0] Open Loop. All fixed speed compressors are stopped. The variable speed compressor will continue to run.
Frozen	Staging/destaging of compressors has been locked and reference locked.
Jogging	All fixed speed compressors are stopped. When stopped, the variable speed compressor will run at jog speed.
Running	A Start command is applied to the frequency converter and the Pack controller is controlling the compressors.
Running FSBW	The frequency converter is tripped off and the Pack Controller is controlling the fixed speed compressors based on 4-14 Motor Speed High Limit [Hz].
Staging	The Pack Controller is staging fixed speed compressors.
Destaging	The Pack Controller is destaging fixed speed compressors.
Lead Not Set	No compressor available to be assigned as variable speed compressor.

## Parameter Descriptions

6

### 25-81 Compressor Status

**Option:**      **Function:**

		Compressor Status shows the status for the number of compressors selected in <i>25-06 Number of Pumps</i> . It is a readout of the status for each of the compressors showing a string, which consists of compressor number and the current status of the compressor. Example: Readout is with the abbreviation like "1:D 2:O" This means that compressor 1 is running and speed controlled by the frequency converter and compressor 2 is stopped.
[X]	Disabled	The compressor is interlocked either via <i>25-90 Pump Interlock</i> , or signal on a digital input programmed for Compressor (number on compressor) Interlock in parameter group <i>5-1* Digital Inputs</i> . Can only refer to fixed speed compressors.
[O]	Off	Stopped by the cascade controller (but not interlocked).
[D]	Running on Frequency Converter	Variable speed compressor, regardless if connected directly or controlled via relay in the frequency converter.
[R]	Running on Mains	Running on mains. Fixed speed compressor running.

### 25-82 Lead Compressor

**Option:**      **Function:**

0	N/A	Readout parameter for the actual variable speed compressor in the system. It is updated to reflect the current variable speed compressor in the system when an alternation takes place. If no lead compressor is selected (Cascade Controller disabled or all compressors interlocked) the display will show NONE.
---	-----	--

### 25-83 Relay Status

Array [2]

	On	
	Off	Read out of the status for each of the relays assigned to control the compressors. Every element in the array represents a relay. If a relay is activated, the corresponding element is set to "On". If a relay is deactivated, the corresponding element is set to "Off".

### 25-84 Compressor ON Time

Array [2]

0	[0 – 2147483647 h]	Readout of the value for Compressor ON Time. The Cascade Controller has set counters for the compressors and for the relays that control the compressors. Compressor ON Time monitors the "operating hours" of each compressor. The value of each Compressor ON Time counter can be reset to 0 by writing in the
---	--------------------	--

parameter, e.g. if the compressor is replaced in case of service.

### 25-85 Relay ON Time

Array [2]

0	[0 – 2147483647 h]	Readout of the value for Relay ON time. The Cascade Controller has set counters for the compressors and for the relays that control the compressors. Compressor cycling is always done based on the relay counters, otherwise it would always use the new compressor if a compressor is replaced and its value in <i>25-84 Pump ON Time</i> counter is reset. In order to use <i>25-04 Pump Cycling</i> , the Cascade Controller is monitoring the Relay ON time.
---	--------------------	---

### 25-86 Reset Relay Counters

**Option:**      **Function:**

[0] *	Do not reset	
[1]	Do reset	Resets all elements in <i>25-85 Relay ON Time</i> .

## 6.14.6 25-9\* Service

Parameters used in case of service on one or more of the compressors controlled.

### 25-90 Compressor Interlock

Array [2]

		In this parameter, it is possible to disable one or more of the fixed lead compressors. For example, the compressor will not be selected for staging on even if it is the next compressor in the operation sequence. It is not possible to disable the lead compressor with the Compressor Interlock command. The digital input interlocks are selected as <i>[130 – 132] Compressor 1-3 Interlock</i> in parameter group <i>5-1* Digital Inputs</i> .
[0]	Off	The compressor is active for staging/destaging.
[1]	On	The Compressor Interlock command is given. If a compressor is running it is immediately destaged. If the compressor is not running it is not allowed to stage on.

### 25-91 Manual Alternation

**Option:**      **Function:**

[0]	0 = Off - Number of Compressors	This parameter is only active if the options <i>At Command</i> or <i>At Staging or Command</i> are selected in <i>25-50 Lead Compressor Alternation</i> . The parameter is for manually setting of what compressor to be assigned as variable speed compressor. The default value of Manual Alternation is <i>[0] Off</i> . If a
-----	---------------------------------	--

---

**Parameter Descriptions**

---

**25-91 Manual Alternation**

<b>Option:</b>	<b>Function:</b>
	value other than [0] Off is set, the alternation is carried out immediately and the compressor that is selected with Manual Alternation is the new variable speed compressor. After the alternation has been carried out, the Manual Alternation parameter is reset to [0] Off. If the parameter is set to the number which equals the actual variable speed compressor, the parameter will be reset to [0] immediately after.



## 6.15 Parameters: 28-\*\* Compressor Functions

### 6.15.1 28-0\* Short Cycle Protection

When controlling refrigeration compressors, there is often a need for limiting the numbers of starts. One way to limit the starts is to ensure a minimum run time (time between a start and a stop) and a minimum interval between starts. *28-02 Minimum Run Time* can override any normal stop command and *28-01 Interval between Starts* can override any normal start command (Start/Jog/Freeze).

None of the two functions are active if *Hand On* or *Off* modes have been activated via the keypad. If selecting *Hand On* or *Off*, the two timers will be reset to 0, and not start counting until *Auto* is pressed and an active start command applied.

28-00 Short Cycle Protection		
Option:	Function:	
[0] *	Disabled	Timer set in <i>28-01 Interval between Starts</i> is disabled.
[1]	Enabled	Timer set in <i>28-01 Interval between Starts</i> is enabled.

#### NOTICE

This parameter can only be [1] Enabled if *25-00 Cascade Controller* is set to [0] Disabled.

28-01 Interval Between Starts		
Range:	Function:	
300 s*	[0 - 3600 s]	Sets the time desired as minimum time between two starts. Any normal start command (Start/Jog/Freeze) is disregarded until the timer has expired.

28-02 Minimum Run Time		
Range:	Function:	
12 s*	[0 - par. 28-01]	Sets the time desired as minimum run time after a normal start command (Start/Jog/Freeze). Any normal stop command is disregarded until the set time has expired. The timer starts counting following a normal start command (Start/Jog/Freeze). A Coast (Inverse) or an External Interlock command override the timer.

#### NOTICE

Does not work in cascade mode.

### 6.15.2 28-1\* Oil Return Management

Insufficient lubrication can be the result of oil depositing itself in pipes and bends. Return oil deposits to the crankcase by increasing velocity for short periods at

regular time intervals or by ensuring adequate oil return when velocity is too low.

With Oil Return Management, these two oil return mechanisms can be programmed into the Compressor Drive™. With Oil Return Management enabled, the frequency converter performs oil return by boosting the compressor speed to 4200 RPM (70 Hz) for a selectable duration. Programme the duration in *28-13 Boost Duration*. The boosts are performed at fixed time intervals (programmed in *28-12 Fixed Boost Interval*) or if the compressor speed has been less than 3000 RPM (50 Hz) for too long (as programmed in *28-11 Low Speed Running Time*), whichever occurs first. Thus, the maximum time between two consecutive oil return boosts is as programmed in *28-12 Fixed Boost Interval*. A text message on the keypad indicates oil return boosts.

#### NOTICE

If *4-13 Motor Speed High Limit [RPM]* or *4-14 Motor Speed High Limit [Hz]* is set to the boost speed 4200 RPM an oil boost may cause unwanted staging or destaging if parameter group *25-\*\* Cascade Controller* is active.

28-10 Oil Return Management		
Option:	Function:	
[0] *	Off	No function
[1]	On	Oil return mechanism is active.

28-11 Low Speed Running Time		
Range:	Function:	
60 min*	[1 - 1440 min]	Running at low speeds for extended periods may result in inadequate oil return to the compressor crankcase. Set this parameter to the maximum running time the compressor is allowed to run at a speed below 3000 RPM/50 Hz. An oil return boost is performed each time the compressor has been running at a low speed for this maximum time.

28-12 Fixed Boost Interval		
Range:	Function:	
24 h*	[1 - 168 h]	An oil return boost is performed at fixed time intervals to complement the oil return boosts triggered by inadequate flow speeds ( <i>28-11 Low Speed Running Time</i> ). The fixed interval boosts ensure that oil return boosts are performed even when no boosts have occurred due to low flow speed ( <i>28-11 Low Speed Running Time</i> ).

28-13 Boost Duration		
Range:	Function:	
30 s*	[10 - 120 s]	This parameter controls the duration of oil return boosts.

### 6.15.3 28-2\* Discharge Temperature Monitor

The Discharge Temperature Monitor (DTM) can be used to prevent the discharge temperature from reaching dangerous levels.

Two temperature levels of increasing severity can be programmed. These levels are called warning level (set in 28-24 *Warning Level*) and emergency level (set in 28-26 *Emergency Level*) in order of increasing severity. Each level corresponds to a particular set of preventive actions.

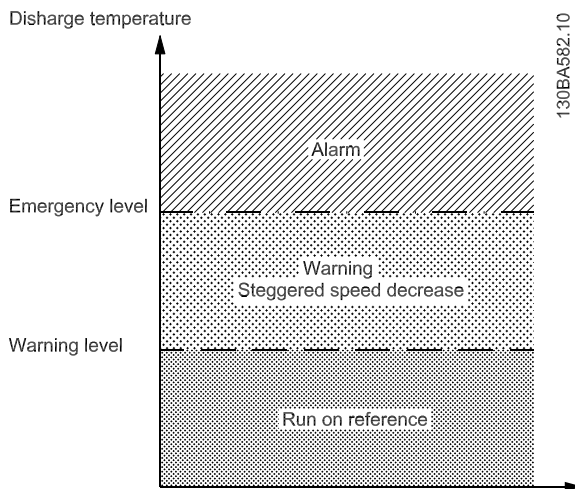

Illustration 6.38 Discharge Temperature Levels

To prevent damaging the compressor, discharge temperatures above the Emergency level cause an alarm and an immediate trip.

Normal operations apply for discharge temperatures below Warning level. The discharge temperature is passively monitored without affecting frequency converter operations.

Discharge temperatures in the range from Warning level to Emergency level trigger a warning and an action set by 28-25 *Warning Action*. The action can be None or Decrease cooling. If the action is set to Decrease cooling, the cooling is decreased as a preventive action in an attempt to lower the discharge temperature.

Decrease cooling by step-wise lowering of the shaft speed until the discharge temperature either drops below warning level or exceeds emergency level. Each step represents a three minute period during which the maximum allowed shaft speed is 10 Hz lower than the previous step. The initial step occurs when the discharge temperature rises from below to above warning level and

uses the current shaft speed as basis for the 10 Hz speed reduction.

The speed steps enforce maximum shaft speeds. If the reference corresponds to a lesser speed, the reference is obeyed. If it corresponds to a higher speed, the speed is limited to the maximum shaft speed for that step.

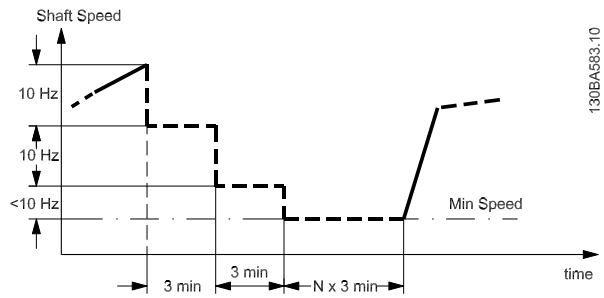

Illustration 6.39 Speed Steps

#### NOTICE

If the Cascade Controller is active, unwanted staging or destaging may result if the Discharge Temperature Monitor reduces the speed to 4-11 *Motor Speed Low Limit [RPM]* or 4-12 *Motor Speed Low Limit [Hz]*.

#### 28-20 Temperature Source

Option: Function:

Option:	Function:
[0] *	None No Source. The Discharge Temperature Monitor is not active.
[1]	Analog input 53 The measurement device is connected to input terminal 53. Program 6-10 <i>Terminal 53 Low Voltage</i> to 6-15 <i>Terminal 53 High Ref./Feedb. Value</i> to match the characteristics of the device.
[2]	Analog input 54 The measurement device is connected to input terminal 54. Program 6-20 <i>Terminal 54 Low Voltage</i> to 6-25 <i>Terminal 54 High Ref./Feedb. Value</i> to match the characteristics of the device.
[3]	Bus The actual discharge temperature should be sent via Modbus RTU or FC protocol to 28-27 <i>Discharge temperature</i> . The temperature could be set via PCD write in 8-42 <i>PCD Write Configuration</i> .

#### 28-21 Temperature Unit

Option: Function:

Option:	Function:
[60] *	°C
[160]	°F

## Parameter Descriptions

### 28-24 Warning Level

Range:	Function:
130 * [10– 28-26 Emergency Level]	Selects the temperature at which a warning shall be issued. The action selected in 28-25 Warning Action becomes active at this temperature. Enter the temperature measured in the unit selected in 28-21 Temperature Unit.

### 28-25 Warning Action

Option:	Function:
[0]	None No action. Only a warning is issued.
[1] *	Decrease cooling A warning is issued and the motor speed is lowered in steps of 10 Hz every 3 minutes until the temperature either drops below the level programmed in 28-24 Warning Level or exceeds the level programmed in 28-26 Emergency Level.

### 28-26 Emergency Level

Range:	Function:
145* [28-24 Warning Level-300]	Selects the temperature at which an alarm shall be issued. Enter the temperature in the unit programmed in 28-21 Temperature Unit.

### 28-27 Discharge Temperature

Range:	Function:
0* [-2147483648 – 2147483648]	Returns the actual value of the discharge temperature.

## 6.15.4 28-3\* Crankcase Heating

A DC-hold Current through the motor windings can be used as an alternative to an external crankcase heater to keep the compressor warm when stopped.

The efficiency of the Crankcase Heating depends upon the physical placing of the actual motor in the compressor.

If the Crankcase Heating is used together with Anti-Reverse Protection, the frequency converter first brakes for the set duration followed by the heating current.

### 28-30 Crankcase Heating Control

Option:	Function:
[0] *	Disabled Activate the DC-hold current when the motor is stopped. The current level is defined in 28-31 Heating DC Current.
[1]	Enabled

### 28-31 Heating DC Current

Range:	Function:
20% * [0 – 25%]	Set the DC-hold current as percentage of the rated motor current in 1-24 Motor Current.

### 28-32 Crankcase Heating Delayed

Range:	Function:
5 s* [5-65534 s]	This time defines the delay after a stop and until Crank Case Heating is applied to the compressor.

## 6.15.5 28-4\* Anti-reverse Protection

A compressor may have a preferred rotation direction and the instructions for cabling should always be followed, but the consequences of a reverse rotation are normally not fatal. Set up parameter group 28-4\* Anti-reverse Protection to prevent reverse rotation at stop by injecting a DC-brake current into the motor a few seconds after stop followed by the eventual coast of the motor when the discharge valve has closed.

### NOTICE

The DC-brake Function is not operational before any Start Function has completed. In case of an emergency stop before the starting sequence has completed then the compressor may rotate reverse for a short moment after stop. Under normal circumstances, the Short Cycle Protection feature ensures the correct sequence.

### 28-40 Reverse Protection Control

Option:	Function:
[0] *	Disabled Activate a DC-brake current when the motor is stopped. The current level is defined in 28-41 DC Brake Current. Not recommended for Piston compressors.
[1]	Enabled

### 28-41 DC Brake Current

Range:	Function:
90% * [0 – max motor current ]	Set the DC-brake current as percentage of the rated motor current in 1-24 Motor Current.

### 28-42 DC Braking Time

Range:	Function:
2.0 s* [0 – 60.0 s]	Set the duration of the DC-brake current.

## Parameter Descriptions

### 28-43 DC Brake Cut-in Speed [RPM]

Range:		Function:
700 RPM '0' = Off*	[0 – max motor speed]	Set the speed where the DC-brake Current should cut in. The speed must be higher than 0 RPM for the DC-brake to activate before the motor is coasted at 0 RPM to prevent a reverse rotation.

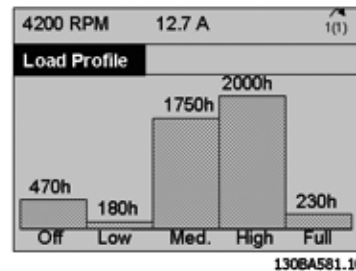

### 6.15.6 28-5\* Load Profile

The Load Profiler is used to get a graphical presentation of the load pattern a cooling system has been subjected to over the last 6 months. The system load is assumed to be proportional to the compressor speed, and the Load Profiler measures the load as the running hours spent operating within certain speed intervals.

The speed intervals are calculated based on 4-11 Motor Speed Low Limit [RPM] (4-13 Motor Speed High Limit [RPM]) and 4-13 Motor Speed High Limit [RPM] (4-14 Motor Speed High Limit [Hz]) to match 0%, 25%, 50%, 75% and 100% loads as good as possible. The speed intervals are denoted "Off", "Low", "Med.", "High" and "Full" and are calculated in the following manner:

$$\Delta = \text{Motor Speed High Limit} - \text{Motor Speed Low Limit}$$

**Off:** Speed = 0

**Low:** Motor Speed Low Limit ≤ Speed  
< Motor Speed Low Limit + Δ / 6

**Med.** Motor Speed  
Low Limit + Δ / 6 ≤ Speed < Motor Speed Low Limit + Δ / 2

**High:** Motor Speed  
Low Limit + Δ / 2 ≤ Speed < Motor Speed Low Limit + 5 × Δ / 6

**Full:** Motor Speed  
Low Limit + 5 × Δ / 6 ≤ Speed ≤ Motor Speed High Limit

For example, if 4-11 Motor Speed High Limit is 5400 RPM and Motor Speed Low Limit is 1800 RPM the four calculated intervals become

**Low:** 1800 RPM ≤ speed < 2350 RPM

**Med:** 2350 RPM ≤ speed < 3450 RPM

**High:** 3450 RPM ≤ speed < 4550 RPM

**Full:** 4550 RPM ≤ speed ≤ 5400 RPM

The profile is presented on the keypad as a histogram. In each speed interval, the indicated running time is accurate to within 1 hour.

Illustration 6.40 Load Profile

If [Off] is pressed on the keypad, the Load Profile is not updated.

### 28-50 Reset Load Profile

Option:	Function:	
[0] *	Do not reset	No function
[1]	Reset	Clears the measured running time in all five speed intervals.

### 28-74 Night Speed Drop [RPM]

Range:	Function:
[ ]	The value in this parameter decrements the value in 4-13 Motor Speed High Limit [RPM] which becomes active when night mode is activated.

## 6.16 Parameter Lists

### 6.16.1 Default Settings

#### Changes during operation

"TRUE" means that the parameter can be changed while the frequency converter is in operation. "FALSE" means that the frequency converter must be stopped before a change can be made.

#### 4-Set-up

'All set-ups': the parameter can be set individually in each of the four set-ups, i. e. one single parameter can have four different data values.

'1 set-up': data value will be the same in all set-ups.

Data type	Description	Type
2	Integer 8	Int8
3	Integer 16	Int16
4	Integer 32	Int32
5	Unsigned 8	UInt8
6	Unsigned 16	UInt16
7	Unsigned 32	UInt32
9	Visible String	VisStr
33	Normalized value 2 bytes	N2
35	Bit sequence of 16 Bioolean variables	V2
54	Time difference w/o date	TimD

Table 6.14 Data Types

### 6.16.2 Conversion

The various attributes of each parameter are displayed in factory setting. Parameter values are transferred as whole numbers only. Conversion factors are therefore used to transfer decimals.

*4-12 Motor Speed Low Limit [Hz]* has a conversion factor of 0.1. To preset the minimum frequency to 10 Hz, transfer the value 100. A conversion factor of 0.1 means that the value transferred is multiplied by 0.1. The value 100 is therefore read as 10.0.

Examples:

0 s ⇒ conversion index 0

0.00 s ⇒ conversion index -2

0 ms ⇒ conversion index -3

0.00 ms ⇒ conversion index -5

Conversion index	Conversion factor
100	
75	
74	
67	
6	1000000
5	100000
4	10000
3	1000
2	100
1	10
0	1
-1	0.1
-2	0.01
-3	0.001
-4	0.0001
-5	0.00001
-6	0.000001
-7	0.0000001

Table 6.15 Conversion Table

## Parameter Descriptions

Par. No. #	Parameter description	Default value	4-set-up	Change during operation	Conversion index	Type
<b>0-0* Basic Settings</b>						
0-01	Language	[0] English	1 set-up	TRUE	-	UInt8
0-02	Motor Speed Unit	[1] Hz	2 set-ups	FALSE	-	UInt8
0-03	Regional Settings	ExpressionLimit	2 set-ups	FALSE	-	UInt8
0-04	Operating State at Power-up	[0] Resume	All set-ups	TRUE	-	UInt8
0-05	Local Mode Unit	[0] As Motor Speed Unit	2 set-ups	FALSE	-	UInt8
<b>0-1* Set-up Operations</b>						
0-10	Active Set-up	[1] Set-up 1	1 set-up	TRUE	-	UInt8
0-11	Programming Set-up	[9] Active Set-up	All set-ups	TRUE	-	UInt8
0-12	This Set-up Linked to	[0] Not linked	All set-ups	FALSE	-	UInt8
0-13	Readout: Linked Set-ups	0 N/A	All set-ups	FALSE	0	UInt16
0-14	Readout: Prog. Set-ups / Channel	0 N/A	All set-ups	TRUE	0	Int32
<b>0-2* LCP Display</b>						
0-20	Display Line 1.1 Small	[1662] Analog Input	All set-ups	TRUE	-	UInt16
0-21	Display Line 1.2 Small	ExpressionLimit	All set-ups	TRUE	-	UInt16
0-22	Display Line 1.3 Small	ExpressionLimit[1610] Power kW	All set-ups	TRUE	-	UInt16
0-23	Display Line 2 Large	ExpressionLimit	All set-ups	TRUE	-	UInt16
0-24	Display Line 3 Large	ExpressionLimit	All set-ups	TRUE	-	UInt16
0-25	My Personal Menu	ExpressionLimit	1 set-up	TRUE	0	UInt16
<b>0-3* LCP Custom Readout</b>						
0-30	Custom Readout Unit	[1] %	All set-ups	TRUE	-	UInt8
0-31	Custom Readout Min Value	ExpressionLimit	All set-ups	TRUE	-2	Int32
0-32	Custom Readout Max Value	100 CustomReadoutUnit	All set-ups	TRUE	-2	Int32
0-37	Display Text 1	0 N/A	1 set-up	TRUE	0	VisStr[25]
0-38	Display Text 2	0 N/A	1 set-up	TRUE	0	VisStr[25]
0-39	Display Text 3	0 N/A	1 set-up	TRUE	0	VisStr[25]
<b>0-4* LCP Keypad</b>						
0-40	[Hand on] Key on LCP	[0] Disabled	All set-ups	TRUE	-	UInt8
0-41	[Off] Key on LCP	[1] Enabled	All set-ups	TRUE	-	UInt8
0-42	[Auto on] Key on LCP	[1] Enabled	All set-ups	TRUE	-	UInt8
0-43	[Reset] Key on LCP	[1] Enabled	All set-ups	TRUE	-	UInt8
<b>0-5* Copy/Save</b>						
0-50	LCP Copy	[0] No copy	All set-ups	FALSE	-	UInt8
0-51	Set-up Copy	[0] No copy	All set-ups	FALSE	-	UInt8
<b>0-6* Password</b>						
0-60	Main Menu Password	999	1 set-up	TRUE	0	Int16
0-61	Access to Main Menu w/o Password	[1] LCP: Read only	1 set-up	TRUE	-	UInt8
0-65	Personal Menu Password	200 N/A	1 set-up	TRUE	0	Int16
0-66	Access to Personal Menu w/o Password	[0] Full access	1 set-up	TRUE	-	UInt8
0-67	Bus Password Access	0 N/A	All set-ups	TRUE	0	UInt16
<b>0-7* Clock Settings</b>						
0-70	Set Date and Time	ExpressionLimit	All set-ups	TRUE	0	TimeOfDay
0-71	Date Format	ExpressionLimit	1 set-up	TRUE	-	UInt8
0-72	Time Format	ExpressionLimit	1 set-up	TRUE	-	UInt8
0-74	DST/Summertime	[0] Off	1 set-up	TRUE	-	UInt8
0-76	DST/Summertime Start	ExpressionLimit	1 set-up	TRUE	0	TimeOfDay
0-77	DST/Summertime End	ExpressionLimit	1 set-up	TRUE	0	TimeOfDay
0-79	Clock Fault	[0] Disabled	1 set-up	TRUE	-	UInt8
0-81	Working Days	ExpressionLimit	1 set-up	TRUE	-	UInt8
0-82	Additional Working Days	ExpressionLimit	1 set-up	TRUE	0	TimeOfDay

## Parameter Descriptions

Par. No. #	Parameter description	Default value	4-set-up	Change during operation	Conversion index	Type
0-83	Additional Non-Working Days	ExpressionLimit	1 set-up	TRUE	0	TimeOfDay
0-89	Date and Time Readout	0 N/A	All set-ups	TRUE	0	VisStr[25]

### 6.16.3 1-\*\* Load/Motor

Par. No. #	Parameter description	Default value	4-set-up	Change during operation	Conversion index	Type
<b>1-0* General Settings</b>						
1-00	Configuration Mode	ExpressionLimit	All set-ups	TRUE	-	Uint8
1-03	Torque Characteristics	[0] Compressor CT	All set-ups	TRUE	-	Uint8
<b>1-1* Motor Selection</b>						
1-10	Motor Construction	[0] Asynchron	All set-ups	FALSE	-	Uint8
<b>1-1* VVC+ PM</b>						
1-14	Damping Gain	120 %	All set-ups	TRUE	0	Int16
1-15	Low Speed Filter Time Const.	ExpressionLimit	All set-ups	TRUE	-2	Uint16
1-16	High Speed Filter Time Const.	ExpressionLimit	All set-ups	TRUE	-2	Uint16
1-17	Voltage filter time const.	ExpressionLimit	All set-ups	TRUE	-3	Uint16
<b>1-2* Motor Data</b>						
1-20	Motor Power [kW]	ExpressionLimit	All set-ups	FALSE	1	Uint32
1-21	Motor Power [HP]	ExpressionLimit	All set-ups	FALSE	-2	Uint32
1-22	Motor Voltage	ExpressionLimit	All set-ups	FALSE	0	Uint16
1-23	Motor Frequency	ExpressionLimit	All set-ups	FALSE	0	Uint16
1-24	Motor Current	ExpressionLimit	All set-ups	FALSE	-2	Uint32
1-25	Motor Nominal Speed	ExpressionLimit	All set-ups	FALSE	67	Uint16
1-26	Motor Cont. Rated Torque	ExpressionLimit	All set-ups	FALSE	-1	Uint32
1-28	Motor Rotation Check	[0] Off	All set-ups	FALSE	-	Uint8
1-29	Automatic Motor Adaptation (AMA)	[0] Off	All set-ups	FALSE	-	Uint8
<b>1-3* Adv. Motor Data</b>						
1-30	Stator Resistance (Rs)	ExpressionLimit	All set-ups	FALSE	-4	Uint32
1-31	Rotor Resistance (Rr)	ExpressionLimit	All set-ups	FALSE	-4	Uint32
1-35	Main Reactance (Xh)	ExpressionLimit	All set-ups	FALSE	-4	Uint32
1-36	Iron Loss Resistance (Rfe)	ExpressionLimit	All set-ups	FALSE	-3	Uint32
1-37	d-axis Inductance (Ld)	ExpressionLimit	All set-ups	FALSE	-6	Int32
1-39	Motor Poles	ExpressionLimit	All set-ups	FALSE	0	Uint8
1-40	Back EMF at 1000 RPM	ExpressionLimit	All set-ups	FALSE	0	Uint16
<b>1-5* Load Indep. Setting</b>						
1-50	Motor Magnetisation at Zero Speed	100 %	All set-ups	TRUE	0	Uint16
1-51	Min Speed Normal Magnetising [RPM]	ExpressionLimit	All set-ups	TRUE	67	Uint16
1-52	Min Speed Normal Magnetising [Hz]	ExpressionLimit	All set-ups	TRUE	-1	Uint16
1-58	Flystart Test Pulses Current	ExpressionLimit	All set-ups	FALSE	0	Uint16
1-59	Flystart Test Pulses Frequency	ExpressionLimit	All set-ups	FALSE	0	Uint16
<b>1-6* Load Depen. Setting</b>						
1-60	Low Speed Load Compensation	100 %	All set-ups	TRUE	0	Int16
1-61	High Speed Load Compensation	100 %	All set-ups	TRUE	0	Int16
1-62	Slip Compensation	0 %	All set-ups	TRUE	0	Int16
1-63	Slip Compensation Time Constant	ExpressionLimit	All set-ups	TRUE	-2	Uint16
1-64	Resonance Dampening	100 %	All set-ups	TRUE	0	Uint16
1-65	Resonance Dampening Time Constant	5 ms	All set-ups	TRUE	-3	Uint8
1-66	Min. Current at Low Speed	ExpressionLimit	All set-ups	TRUE	0	Uint8
<b>1-7* Start Adjustments</b>						

## Parameter Descriptions

Par. No. #	Parameter description	Default value	4-set-up	Change during operation	Conversion index	Type
1-70	PM Start Mode	[1] Parking	All set-ups	TRUE	-	Uint8
1-71	Start Delay	00 s	All set-ups	TRUE	-1	Uint16
1-72	Start Function	ExpressionLimit	All set-ups	TRUE	-	Uint8
1-73	Flying Start	ExpressionLimit	All set-ups	FALSE	-	Uint8
1-74	Start Speed [RPM]	ExpressionLimit	All set-ups	TRUE	67	Uint16
1-75	Start Speed [Hz]	ExpressionLimit	All set-ups	TRUE	-1	Uint16
1-76	Start Current	0 A	All set-ups	TRUE	-2	Uint32
1-77	Compressor Start Max Speed [RPM]	ExpressionLimit	All set-ups	TRUE	67	Uint16
1-78	Compressor Start Max Speed [Hz]	ExpressionLimit	All set-ups	TRUE	-1	Uint16
1-79	Compressor Start Max Time to Trip	5 s	All set-ups	TRUE	-1	Uint8
<b>1-8* Stop Adjustments</b>						
1-80	Function at Stop	[0] Coast	All set-ups	TRUE	-	Uint8
1-81	Min Speed for Function at Stop [RPM]	ExpressionLimit	All set-ups	TRUE	67	Uint16
1-82	Min Speed for Function at Stop [Hz]	ExpressionLimit	All set-ups	TRUE	-1	Uint16
1-86	Compressor Min. Speed for Trip [RPM]	ExpressionLimit	All set-ups	TRUE	67	Uint16
1-87	Compressor Min. Speed for Trip [Hz]	ExpressionLimit	All set-ups	TRUE	-1	Uint16
<b>1-9* Motor Temperature</b>						
1-90	Motor Thermal Protection	ExpressionLimit	All set-ups	TRUE	-	Uint8
1-91	Motor External Fan	[0] None	All set-ups	TRUE	-	Uint8
1-93	Thermistor Source	[0] None	All set-ups	TRUE	-	Uint8



## Parameter Descriptions

### 6.16.4 3-\*\* Reference/Ramps

Par. No. #	Parameter description	Default value	4-set-up	Change during operation	Conversion index	Type
<b>3-0* Reference Limits</b>						
3-02	Minimum Reference	ExpressionLimit	All set-ups	TRUE	-3	Int32
3-03	Maximum Reference	ExpressionLimit	All set-ups	TRUE	-3	Int32
3-04	Reference Function	[0] Sum	All set-ups	TRUE	-	UInt8
<b>3-1* References</b>						
3-10	Preset Reference	0 %	All set-ups	TRUE	-2	Int16
3-11	Jog Speed [Hz]	ExpressionLimit	All set-ups	TRUE	-1	UInt16
3-13	Reference Site	[0] Linked to Hand / Auto	All set-ups	TRUE	-	UInt8
3-14	Preset Relative Reference	0 %	All set-ups	TRUE	-2	Int32
3-15	Reference 1 Source	[1] Analog Input 53	All set-ups	TRUE	-	UInt8
3-16	Reference 2 Source	[20] Digital pot.meter	All set-ups	TRUE	-	UInt8
3-17	Reference 3 Source	[0] No function	All set-ups	TRUE	-	UInt8
3-19	Jog Speed [RPM]	ExpressionLimit	All set-ups	TRUE	67	UInt16
<b>3-4* Ramp 1</b>						
3-41	Ramp 1 Ramp Up Time	Size related	All set-ups	TRUE	-2	UInt32
3-42	Ramp 1 Ramp Down Time	Size related	All set-ups	TRUE	-2	UInt32
<b>3-5* Ramp 2</b>						
3-51	Ramp 2 Ramp Up Time	ExpressionLimit	All set-ups	TRUE	-2	UInt32
3-52	Ramp 2 Ramp Down Time	ExpressionLimit	All set-ups	TRUE	-2	UInt32
<b>3-8* Other Ramps</b>						
3-80	Jog Ramp Time	ExpressionLimit	All set-ups	TRUE	-2	UInt32
3-81	Quick Stop Ramp Time	ExpressionLimit	2 set-ups	TRUE	-2	UInt32
3-82	Starting Ramp Up Time	ExpressionLimit	2 set-ups	TRUE	-2	UInt32
<b>3-9* Digital Pot.Meter</b>						
3-90	Step Size	0.10 %	All set-ups	TRUE	-2	UInt16
3-91	Ramp Time	1 s	All set-ups	TRUE	-2	UInt32
3-92	Power Restore	[0] Off	All set-ups	TRUE	-	UInt8
3-93	Maximum Limit	100 %	All set-ups	TRUE	0	Int16
3-94	Minimum Limit	0 %	All set-ups	TRUE	0	Int16
3-95	Ramp Delay	1 N/A	All set-ups	TRUE	-3	TimD

## Parameter Descriptions

### 6.16.5 4-\*\* Limits/Warnings

Par. No. #	Parameter description	Default value	4-set-up	Change during operation	Conversion index	Type
<b>4-1* Motor Limits</b>						
4-10	Motor Speed Direction	[0] Clockwise	All set-ups	FALSE	-	Uint8
4-11	Motor Speed Low Limit [RPM]	ExpressionLimit	All set-ups	TRUE	67	Uint16
4-12	Motor Speed Low Limit [Hz]	ExpressionLimit	All set-ups	TRUE	-1	Uint16
4-13	Motor Speed High Limit [RPM]	ExpressionLimit	All set-ups	TRUE	67	Uint16
4-14	Motor Speed High Limit [Hz]	ExpressionLimit	All set-ups	TRUE	-1	Uint16
4-16	Torque Limit Motor Mode	110 %	All set-ups	TRUE	-1	Uint16
4-17	Torque Limit Generator Mode	100 %	All set-ups	TRUE	-1	Uint16
4-18	Current Limit	ExpressionLimit	All set-ups	TRUE	-1	Uint32
4-19	Max Output Frequency	ExpressionLimit	All set-ups	FALSE	-1	Uint16
<b>4-5* Adj. Warnings</b>						
4-50	Warning Current Low	0 A	All set-ups	TRUE	-2	Uint32
4-51	Warning Current High	ImaxTRV200 (P1637)	All set-ups	TRUE	-2	Uint32
4-52	Warning Speed Low	0 RPM	All set-ups	TRUE	67	Uint16
4-53	Warning Speed High	outputSpeedHighLimit (P413)	All set-ups	TRUE	67	Uint16
4-54	Warning Reference Low	-999999 N/A	All set-ups	TRUE	-3	Int32
4-55	Warning Reference High	999999 N/A	All set-ups	TRUE	-3	Int32
4-56	Warning Feedback Low	-999999 ReferenceFeed-backUnit	All set-ups	TRUE	-3	Int32
4-57	Warning Feedback High	999999 ReferenceFeed-backUnit	All set-ups	TRUE	-3	Int32
4-58	Missing Motor Phase Function	ExpressionLimit	All set-ups	TRUE	-	Uint8
<b>4-6* Speed Bypass</b>						
4-60	Bypass Speed From [RPM]	ExpressionLimit	All set-ups	TRUE	67	Uint16
4-61	Bypass Speed From [Hz]	ExpressionLimit	All set-ups	TRUE	-1	Uint16
4-62	Bypass Speed To [RPM]	ExpressionLimit	All set-ups	TRUE	67	Uint16
4-63	Bypass Speed To [Hz]	ExpressionLimit	All set-ups	TRUE	-1	Uint16
4-64	Semi-Auto Bypass Set-up	[0] Off	All set-ups	FALSE	-	Uint8

## Parameter Descriptions

### 6.16.6 5-\*\* Digital In/Out

Par. No. #	Parameter description	Default value	4-set-up	Change during operation	Conversion index	Type
<b>5-0* Digital I/O mode</b>						
5-00	Digital I/O Mode	[0] PNP - Active at 24V	All set-ups	FALSE	-	UInt8
5-01	Terminal 27 Mode	[0] Input	All set-ups	TRUE	-	UInt8
5-02	Terminal 29 Mode	[0] Input	All set-ups	TRUE	-	UInt8
<b>5-1* Digital Inputs</b>						
5-10	Terminal 18 Digital Input	ExpressionLimit	All set-ups	TRUE	-	UInt8
5-11	Terminal 19 Digital Input	ExpressionLimit	All set-ups	TRUE	-	UInt8
5-12	Terminal 27 Digital Input	No operations	All set-ups	TRUE	-	UInt8
5-13	Terminal 29 Digital Input	ExpressionLimit	All set-ups	TRUE	-	UInt8
5-14	Terminal 32 Digital Input	No operations	All set-ups	TRUE	-	UInt8
5-15	Terminal 33 Digital Input	No operations	All set-ups	TRUE	-	UInt8
5-16	Terminal X30/2 Digital Input	ExpressionLimit	All set-ups	TRUE	-	UInt8
5-17	Terminal X30/3 Digital Input	ExpressionLimit	All set-ups	TRUE	-	UInt8
5-18	Terminal X30/4 Digital Input	ExpressionLimit	All set-ups	TRUE	-	UInt8
5-19	Terminal 37 Safe Stop	[3] Safe Stop Warning	All set-ups	TRUE	-	UInt8
<b>5-3* Digital Outputs</b>						
5-30	Terminal 27 Digital Output	[0] No operation	All set-ups	TRUE	-	UInt8
5-31	Terminal 29 Digital Output	[0] No operation	All set-ups	TRUE	-	UInt8
5-32	Term X30/6 Digi Out (MCB 101)	[0] No operation	All set-ups	TRUE	-	UInt8
5-33	Term X30/7 Digi Out (MCB 101)	[0] No operation	All set-ups	TRUE	-	UInt8
<b>5-4* Relays</b>						
5-40	Function Relay	ExpressionLimit	All set-ups	TRUE	-	UInt8
5-41	On Delay, Relay	0.01 s	All set-ups	TRUE	-2	UInt16
5-42	Off Delay, Relay	0.01 s	All set-ups	TRUE	-2	UInt16
<b>5-5* Pulse Input</b>						
5-50	Term. 29 Low Frequency	100 Hz	All set-ups	TRUE	0	UInt32
5-51	Term. 29 High Frequency	100 Hz	All set-ups	TRUE	0	UInt32
5-52	Term. 29 Low Ref./Feedb. Value	0 N/A	All set-ups	TRUE	-3	Int32
5-53	Term. 29 High Ref./Feedb. Value	100 N/A	All set-ups	TRUE	-3	Int32
5-54	Pulse Filter Time Constant #29	100 ms	All set-ups	FALSE	-3	UInt16
5-55	Term. 33 Low Frequency	100 Hz	All set-ups	TRUE	0	UInt32
5-56	Term. 33 High Frequency	100 Hz	All set-ups	TRUE	0	UInt32
5-57	Term. 33 Low Ref./Feedb. Value	0 N/A	All set-ups	TRUE	-3	Int32
5-58	Term. 33 High Ref./Feedb. Value	100 N/A	All set-ups	TRUE	-3	Int32
5-59	Pulse Filter Time Constant #33	100 ms	All set-ups	FALSE	-3	UInt16
<b>5-6* Pulse Output</b>						
5-60	Terminal 27 Pulse Output Variable	[0] No operation	All set-ups	TRUE	-	UInt8
5-62	Pulse Output Max Freq #27	5000 Hz	All set-ups	TRUE	0	UInt32
5-63	Terminal 29 Pulse Output Variable	[0] No operation	All set-ups	TRUE	-	UInt8
5-65	Pulse Output Max Freq #29	5000 Hz	All set-ups	TRUE	0	UInt32
5-66	Terminal X30/6 Pulse Output Variable	[0] No operation	All set-ups	TRUE	-	UInt8
5-68	Pulse Output Max Freq #X30/6	5000 Hz	All set-ups	TRUE	0	UInt32
<b>5-9* Bus Controlled</b>						
5-90	Digital & Relay Bus Control	0 N/A	All set-ups	TRUE	0	UInt32
5-93	Pulse Out #27 Bus Control	0 %	All set-ups	TRUE	-2	N2
5-94	Pulse Out #27 Timeout Preset	0 %	1 set-up	TRUE	-2	UInt16
5-95	Pulse Out #29 Bus Control	0 %	All set-ups	TRUE	-2	N2
5-96	Pulse Out #29 Timeout Preset	0 %	1 set-up	TRUE	-2	UInt16
5-97	Pulse Out #X30/6 Bus Control	0 %	All set-ups	TRUE	-2	N2

---

**Parameter Descriptions**

---

Par. No. #	Parameter description	Default value	4-set-up	Change during operation	Conversion index	Type
5-98	Pulse Out #X30/6 Timeout Preset	0 %	1 set-up	TRUE	-2	Uint16

## Parameter Descriptions

### 6.16.7 6-\*\* Analog In/Out

Par. No. #	Parameter description	Default value	4-set-up	Change during operation	Conversion index	Type
<b>6-0* Analog I/O Mode</b>						
6-00	Live Zero Timeout Time	10 s	All set-ups	TRUE	0	Uint8
6-01	Live Zero Timeout Function	[0] Off	All set-ups	TRUE	-	Uint8
6-02	Fire Mode Live Zero Timeout Function	[0] Off	All set-ups	TRUE	-	Uint8
<b>6-1* Analog Input 53</b>						
6-10	Terminal 53 Low Voltage	0.07 V	All set-ups	TRUE	-2	Int16
6-11	Terminal 53 High Voltage	10 V	All set-ups	TRUE	-2	Int16
6-12	Terminal 53 Low Current	4 mA	All set-ups	TRUE	-5	Int16
6-13	Terminal 53 High Current	20 mA	All set-ups	TRUE	-5	Int16
6-14	Terminal 53 Low Ref./Feedb. Value	0 N/A	All set-ups	TRUE	-3	Int32
6-15	Terminal 53 High Ref./Feedb. Value	ExpressionLimit	All set-ups	TRUE	-3	Int32
6-16	Terminal 53 Filter Time Constant	0.001 s	All set-ups	TRUE	-3	Uint16
6-17	Terminal 53 Live Zero	[1] Enabled	All set-ups	TRUE	-	Uint8
<b>6-2* Analog Input 54</b>						
6-20	Terminal 54 Low Voltage	0.07 V	All set-ups	TRUE	-2	Int16
6-21	Terminal 54 High Voltage	10 V	All set-ups	TRUE	-2	Int16
6-22	Terminal 54 Low Current	4 mA	All set-ups	TRUE	-5	Int16
6-23	Terminal 54 High Current	20 mA	All set-ups	TRUE	-5	Int16
6-24	Terminal 54 Low Ref./Feedb. Value	-1 N/A	All set-ups	TRUE	-3	Int32
6-25	Terminal 54 High Ref./Feedb. Value	ExpressionLimit	All set-ups	TRUE	-3	Int32
6-26	Terminal 54 Filter Time Constant	0.001 s	All set-ups	TRUE	-3	Uint16
6-27	Terminal 54 Live Zero	[1] Enabled	All set-ups	TRUE	-	Uint8
<b>6-3* Analog Input X30/11</b>						
6-30	Terminal X30/11 Low Voltage	0.07 V	All set-ups	TRUE	-2	Int16
6-31	Terminal X30/11 High Voltage	10 V	All set-ups	TRUE	-2	Int16
6-34	Term. X30/11 Low Ref./Feedb. Value	0 N/A	All set-ups	TRUE	-3	Int32
6-35	Term. X30/11 High Ref./Feedb. Value	100 N/A	All set-ups	TRUE	-3	Int32
6-36	Term. X30/11 Filter Time Constant	0.001 s	All set-ups	TRUE	-3	Uint16
6-37	Term. X30/11 Live Zero	[1] Enabled	All set-ups	TRUE	-	Uint8
<b>6-4* Analog Input X30/12</b>						
6-40	Terminal X30/12 Low Voltage	0.07 V	All set-ups	TRUE	-2	Int16
6-41	Terminal X30/12 High Voltage	10 V	All set-ups	TRUE	-2	Int16
6-44	Term. X30/12 Low Ref./Feedb. Value	0 N/A	All set-ups	TRUE	-3	Int32
6-45	Term. X30/12 High Ref./Feedb. Value	100 N/A	All set-ups	TRUE	-3	Int32
6-46	Term. X30/12 Filter Time Constant	0.001 s	All set-ups	TRUE	-3	Uint16
6-47	Term. X30/12 Live Zero	[1] Enabled	All set-ups	TRUE	-	Uint8
<b>6-5* Analog Output 42</b>						
6-50	Terminal 42 Output	[100] Output frequency	All set-ups	TRUE	-	Uint8
6-51	Terminal 42 Output Min Scale	0 %	All set-ups	TRUE	-2	Int16
6-52	Terminal 42 Output Max Scale	100 %	All set-ups	TRUE	-2	Int16
6-53	Terminal 42 Output Bus Control	0 %	All set-ups	TRUE	-2	N2
6-54	Terminal 42 Output Timeout Preset	0 %	1 set-up	TRUE	-2	Uint16
<b>6-6* Analog Output X30/8</b>						
6-60	Terminal X30/8 Output	[0] No operation	All set-ups	TRUE	-	Uint8
6-61	Terminal X30/8 Min. Scale	0 %	All set-ups	TRUE	-2	Int16
6-62	Terminal X30/8 Max. Scale	100 %	All set-ups	TRUE	-2	Int16
6-63	Terminal X30/8 Output Bus Control	0 %	All set-ups	TRUE	-2	N2
6-64	Terminal X30/8 Output Timeout Preset	0 %	1 set-up	TRUE	-2	Uint16

## Parameter Descriptions

### 6.16.8 7-\*\* Controllers

Par. No. #	Parameter description	Default value	4-set-up	Change during operation	Conversion index	Type
<b>7-0* Speed PID Ctrl.</b>						
7-00	Speed PID Feedback Source	null	All set-ups	FALSE	-	Uint8
7-02	Speed PID Proportional Gain	App.Dependent	All set-ups	TRUE	-3	Uint16
7-03	Speed PID Integral Time	App.Dependent	All set-ups	TRUE	-4	Uint32
7-04	Speed PID Differentiation Time	App.Dependent	All set-ups	TRUE	-4	Uint16
7-05	Speed PID Diff. Gain Limit	5.0 N/A	All set-ups	TRUE	-1	Uint16
7-06	Speed PID Lowpass Filter Time	App.Dependent	All set-ups	TRUE	-4	Uint16
7-07	Speed PID Feedback Gear Ratio	1.0000 N/A	All set-ups	FALSE	-4	Uint32
7-08	Speed PID Feed Forward Factor	0%	All set-ups	FALSE	0	Uint16
7-09	Speed PID Error Correction w/ Ramp	300RPM	All set-ups	TRUE	67	Uint32
<b>7-1* Torque PI Ctrl.</b>						
7-12	Torque PI Proportional Gain	100%	All set-ups	TRUE	0	Uint16
7-13	Torque PI Integration Time	0.020 s	All set-ups	TRUE	-3	Uint16
<b>7-2* Process Ctrl. Feedb</b>						
7-20	Process CL Feedback 1 Resource	[0] No function	All set-ups	TRUE	-	Uint8
7-22	Process CL Feedback 2 Resource	[0] No function	All set-ups	TRUE	-	Uint8
<b>7-3* Process PID Ctrl.</b>						
7-30	Process PID Normal/ Inverse Control	[0] Normal	All set-ups	TRUE	-	Uint8
7-31	Process PID Anti Windup	[1] On	All set-ups	TRUE	-	Uint8
7-32	Process PID Start Speed	0 RPM	All set-ups	TRUE	67	Uint16
7-33	Process PID Proportional Gain	0.01 N/A	All set-ups	TRUE	-2	Uint16
7-34	Process PID Integral Time	10000.00 s	All set-ups	TRUE	-2	Uint32
7-35	Process PID Differentiation Time	0.00 s	All set-ups	TRUE	-2	Uint16
7-36	Process PID Diff. Gain Limit	5.0 N/A	All set-ups	TRUE	-1	Uint16
7-38	Process PID Feed Forward Factor	0%	All set-ups	TRUE	0	Uint16
7-39	On Reference Bandwidth	5%	All set-ups	TRUE	0	Uint8

## Parameter Descriptions

### 6.16.9 8-\*\* Comm. and Options

Par. No. #	Parameter description	Default value	4-set-up	Change during operation	Conversion index	Type
<b>8-0* General Settings</b>						
8-01	Control Site	[0] Digital and ctrl.word	All set-ups	TRUE	-	Uint8
8-02	Control Word Source	ExpressionLimit	All set-ups	TRUE	-	Uint8
8-03	Control Word Timeout Time	20 s	1 set-up	TRUE	-1	Uint32
8-04	Control Word Timeout Function	[0] Off	1 set-up	TRUE	-	Uint8
8-05	End-of-Timeout Function	[1] Resume set-up	1 set-up	TRUE	-	Uint8
8-06	Reset Control Word Timeout	[0] Do not reset	All set-ups	TRUE	-	Uint8
8-07	Diagnosis Trigger	[0] Disable	2 set-ups	TRUE	-	Uint8
<b>8-1* Ctrl. Word Settings</b>						
8-10	Control Word Profile	[0] FC profile	All set-ups	TRUE	-	Uint8
8-13	Configurable Status Word STW	[1] Profile Default	All set-ups	TRUE	-	Uint8
8-16	Store Data Values	[0] Off	All set-ups	TRUE	-	Uint8
<b>8-3* FC Port Settings</b>						
8-30	Protocol	[0] FC	1 set-up	TRUE	-	Uint8
8-31	Address	1 N/A	1 set-up	TRUE	0	Uint8
8-32	FC Port Baud Rate	ExpressionLimit	1 set-up	TRUE	-	Uint8
8-33	Parity / Stop Bits	ExpressionLimit	1 set-up	TRUE	-	Uint8
8-35	Minimum Response Delay	10 ms	1 set-up	TRUE	-3	Uint16
8-36	Max Response Delay	ExpressionLimit	1 set-up	TRUE	-3	Uint16
8-37	Max Inter-Char Delay	ExpressionLimit	1 set-up	TRUE	-5	Uint16
<b>8-4* FC MC protocol set</b>						
8-40	Telegram Selection	[1] Standard telegram 1	2 set-ups	TRUE	-	Uint8
8-42	PCD Write Configuration	ExpressionLimit	2 set-ups	TRUE	-	Uint16
8-43	PCD Read Configuration	ExpressionLimit	2 set-ups	TRUE	-	Uint16
<b>8-5* Digital/Bus</b>						
8-50	Coasting Select	[3] Logic OR	All set-ups	TRUE	-	Uint8
8-51	Quick Stop Select	[3] Logic OR	All set-ups	TRUE	-	Uint8
8-52	DC Brake Select	[3] Logic OR	All set-ups	TRUE	-	Uint8
8-53	Start Select	[3] Logic OR	All set-ups	TRUE	-	Uint8
8-54	Reversing Select	[3] Logic OR	All set-ups	TRUE	-	Uint8
8-55	Set-up Select	[3] Logic OR	All set-ups	TRUE	-	Uint8
8-56	Preset Reference Select	[3] Logic OR	All set-ups	TRUE	-	Uint8
<b>8-8* FC Port Diagnostics</b>						
8-80	Bus Message Count	0 N/A	All set-ups	TRUE	0	Uint32
8-81	Bus Error Count	0 N/A	All set-ups	TRUE	0	Uint32
8-82	Slave Messages Rcvd	0 N/A	All set-ups	TRUE	0	Uint32
8-83	Slave Error Count	0 N/A	All set-ups	TRUE	0	Uint32
<b>8-9* Bus Jog</b>						
8-90	Bus Jog 1 Speed	100 RPM	All set-ups	TRUE	67	Uint16
8-91	Bus Jog 2 Speed	200 RPM	All set-ups	TRUE	67	Uint16

## Parameter Descriptions

### 6.16.10 14-\*\* Special Functions

Par. No. #	Parameter description	Default value	4-set-up	Change during operation	Conversion index	Type
<b>14-0* Inverter Switching</b>						
14-00	Switching Pattern	[1] SFAVM	All set-ups	TRUE	-	Uint8
14-01	Switching Frequency	ExpressionLimit	All set-ups	TRUE	-	Uint8
14-03	Overmodulation	ExpressionLimit	All set-ups	FALSE	-	Uint8
14-04	PWM Random	[0] Off	All set-ups	TRUE	-	Uint8
<b>14-1* Mains On/Off</b>						
14-10	Mains Failure	[3] Coasting	All set-ups	FALSE	-	Uint8
14-11	Mains Voltage at Mains Fault	Size related	All set-ups	TRUE	0	Uint16
14-12	Function at Mains Imbalance	Derate	All set-ups	TRUE	-	Uint8
14-13	Mains Failure Step Factor	1 N/A	All set-ups	TRUE	-1	Uint8
<b>14-2* Trip Reset</b>						
14-20	Reset Mode	[10] Automatic reset x 10	All set-ups	TRUE	-	Uint8
14-21	Automatic Restart Time	30 s	All set-ups	TRUE	0	Uint16
14-22	Operation Mode	[0] Normal operation	All set-ups	TRUE	-	Uint8
14-23	Typecode Setting	ExpressionLimit	2 set-ups	FALSE	-	Uint8
14-25	Trip Delay at Torque Limit	60 s	All set-ups	TRUE	0	Uint8
14-26	Trip Delay at Inverter Fault	ExpressionLimit	All set-ups	TRUE	0	Uint8
14-28	Production Settings	[0] No action	All set-ups	TRUE	-	Uint8
14-29	Service Code	0 N/A	All set-ups	TRUE	0	Int32
<b>14-3* Current Limit Ctrl.</b>						
14-30	Current Lim Cont, Proportional Gain	100 %	All set-ups	FALSE	0	Uint16
14-31	Current Lim Contr, Integration Time	0.020 s	All set-ups	FALSE	-3	Uint16
14-32	Current Lim Ctrl, Filter Time	26 ms	All set-ups	TRUE	-4	Uint16
<b>14-4* Energy Optimising</b>						
14-40	VT Level	66 %	All set-ups	FALSE	0	Uint8
14-41	AEO Minimum Magnetisation	40 %	All set-ups	TRUE	0	Uint8
14-42	Minimum AEO Frequency	30 Hz	All set-ups	TRUE	0	Uint8
14-43	Motor Cosphi	ExpressionLimit	All set-ups	TRUE	-2	Uint16
<b>14-5* Environment</b>						
14-50	RFI Filter	[0] Off	1 set-up	FALSE	-	Uint8
14-52	Fan Control	[0] Auto	All set-ups	TRUE	-	Uint8
14-53	Fan Monitor	[0] Disabled	All set-ups	TRUE	-	Uint8
14-55	Output Filter	[0] No Filter	1 set-up	FALSE	-	Uint8
14-56	Capacitance Output Filter	2 uF	1 set-up	FALSE	-7	Uint16
14-57	Inductance Output Filter	7 mH	1 set-up	FALSE	-6	Uint16
<b>14-6* Auto Derate</b>						
14-60	Function at Over Temperature	[1] Derate	All set-ups	TRUE	-	Uint8
14-61	Function at Inverter Overload	[1] Derate	All set-ups	TRUE	-	Uint8
14-62	Inv. Overload Derate Current	95 %	All set-ups	TRUE	0	Uint16
<b>14-9* Fault Settings</b>						
14-90	Fault Level	ExpressionLimit	1 set-up	TRUE	-	Uint8



## Parameter Descriptions

### 6.16.11 15-\*\* Drive Information

Par. No. #	Parameter description	Default value	4-set-up	Change during operation	Conversion index	Type
<b>15-0* Operating Data</b>						
15-00	Operating hours	0 h	All set-ups	FALSE	74	UInt32
15-01	Running Hours	0 h	All set-ups	FALSE	74	UInt32
15-02	kWh Counter	0 kWh	All set-ups	FALSE	75	UInt32
15-03	Power Up's	0 N/A	All set-ups	FALSE	0	UInt32
15-04	Over Temp's	0 N/A	All set-ups	FALSE	0	UInt16
15-05	Over Volt's	0 N/A	All set-ups	FALSE	0	UInt16
15-06	Reset kWh Counter	[0] Do not reset	All set-ups	TRUE	-	UInt8
15-07	Reset Running Hours Counter	[0] Do not reset	All set-ups	TRUE	-	UInt8
15-08	Number of Starts	0 N/A	All set-ups	FALSE	0	UInt32
<b>15-1* Data Log Settings</b>						
15-10	Logging Source	0	2 set-ups	TRUE	-	UInt16
15-11	Logging Interval	ExpressionLimit	2 set-ups	TRUE	-3	TimD
15-12	Trigger Event	[0] False	1 set-up	TRUE	-	UInt8
15-13	Logging Mode	[0] Log always	2 set-ups	TRUE	-	UInt8
15-14	Samples Before Trigger	50 N/A	2 set-ups	TRUE	0	UInt8
<b>15-2* Historic Log</b>						
15-20	Historic Log: Event	0 N/A	All set-ups	FALSE	0	UInt8
15-21	Historic Log: Value	0 N/A	All set-ups	FALSE	0	UInt32
15-22	Historic Log: Time	0 ms	All set-ups	FALSE	-3	UInt32
15-23	Historic log: Date and Time	ExpressionLimit	All set-ups	FALSE	0	TimeOfDay
<b>15-3* Alarm Log</b>						
15-30	Alarm Log: Error Code	0 N/A	All set-ups	FALSE	0	UInt8
15-31	Alarm Log: Value	0 N/A	All set-ups	FALSE	0	Int16
15-32	Alarm Log: Time	0 s	All set-ups	FALSE	0	UInt32
15-33	Alarm Log: Date and Time	ExpressionLimit	All set-ups	FALSE	0	TimeOfDay
15-34	Alarm Log: Status	0 N/A	All set-ups	FALSE	0	UInt8
15-35	Alarm Log: Alarm Text	0 N/A	All set-ups	FALSE	0	VisStr[32]
<b>15-4* Drive Identification</b>						
15-40	FC Type	0 N/A	All set-ups	FALSE	0	VisStr[6]
15-41	Power Section	0 N/A	All set-ups	FALSE	0	VisStr[20]
15-42	Voltage	0 N/A	All set-ups	FALSE	0	VisStr[20]
15-43	Software Version	0 N/A	All set-ups	FALSE	0	VisStr[5]
15-44	Ordered Typecode String	0 N/A	All set-ups	FALSE	0	VisStr[40]
15-45	Actual Typecode String	0 N/A	All set-ups	FALSE	0	VisStr[40]
15-46	Frequency Converter Ordering No	0 N/A	All set-ups	FALSE	0	VisStr[8]
15-47	Power Card Ordering No	0 N/A	All set-ups	FALSE	0	VisStr[8]
15-48	LCP Id No	0 N/A	All set-ups	FALSE	0	VisStr[20]
15-49	SW ID Control Card	0 N/A	All set-ups	FALSE	0	VisStr[20]
15-50	SW ID Power Card	0 N/A	All set-ups	FALSE	0	VisStr[20]
15-51	Frequency Converter Serial Number	0 N/A	All set-ups	FALSE	0	VisStr[10]
15-53	Power Card Serial Number	0 N/A	All set-ups	FALSE	0	VisStr[19]
<b>15-6* Option Ident</b>						
15-60	Option Mounted	0 N/A	All set-ups	FALSE	0	VisStr[30]
15-61	Option SW Version	0 N/A	All set-ups	FALSE	0	VisStr[20]
15-62	Option Ordering No	0 N/A	All set-ups	FALSE	0	VisStr[8]
15-63	Option Serial No	0 N/A	All set-ups	FALSE	0	VisStr[18]
15-70	Option in Slot A	0 N/A	All set-ups	FALSE	0	VisStr[30]
15-71	Slot A Option SW Version	0 N/A	All set-ups	FALSE	0	VisStr[20]

## Parameter Descriptions

Par. No. #	Parameter description	Default value	4-set-up	Change during operation	Conversion index	Type
15-72	Option in Slot B	0 N/A	All set-ups	FALSE	0	VisStr[30]
15-73	Slot B Option SW Version	0 N/A	All set-ups	FALSE	0	VisStr[20]
15-74	Option in Slot C0/E0	0 N/A	All set-ups	FALSE	0	VisStr[30]
15-75	Slot C0/E0 Option SW Version	0 N/A	All set-ups	FALSE	0	VisStr[20]
15-76	Option in Slot C1/E1	0 N/A	All set-ups	FALSE	0	VisStr[30]
15-77	Slot C1/E1 Option SW Version	0 N/A	All set-ups	FALSE	0	VisStr[20]
<b>15-9* Parameter Info</b>						
15-92	Defined Parameters	0 N/A	All set-ups	FALSE	0	Uint16
15-93	Modified Parameters	0 N/A	All set-ups	FALSE	0	Uint16
15-99	Parameter Metadata	0 N/A	All set-ups	FALSE	0	Uint16

## Parameter Descriptions

### 6.16.12 16-\*\* Data Readouts

Par. No. #	Parameter description	Default value	4-set-up	Change during operation	Conversion index	Type
<b>16-0* General Status</b>						
16-00	Control Word	0 N/A	All set-ups	FALSE	0	V2
16-01	Reference [Unit]	0 ReferenceFeedbackUnit	All set-ups	FALSE	-3	Int32
16-02	Reference [%]	0 %	All set-ups	FALSE	-1	Int16
16-03	Status Word	0 N/A	All set-ups	FALSE	0	V2
16-05	Main Actual Value [%]	0 %	All set-ups	FALSE	-2	N2
16-09	Custom Readout	0 CustomReadoutUnit	All set-ups	FALSE	-2	Int32
<b>16-1* Motor Status</b>						
16-10	Power [kW]	0 kW	All set-ups	FALSE	1	Int32
16-11	Power [hp]	0 hp	All set-ups	FALSE	-2	Int32
16-12	Motor Voltage	0 V	All set-ups	FALSE	-1	UInt16
16-13	Frequency	0 Hz	All set-ups	FALSE	-1	UInt16
16-14	Motor current	0 A	All set-ups	FALSE	-2	Int32
16-15	Frequency [%]	0 %	All set-ups	FALSE	-2	N2
16-16	Torque [Nm]	0 Nm	All set-ups	FALSE	-1	Int32
16-17	Speed [RPM]	0 RPM	All set-ups	FALSE	67	Int32
16-18	Motor Thermal	0 %	All set-ups	FALSE	0	UInt8
16-22	Torque [%]	0 %	All set-ups	FALSE	0	Int16
<b>16-3* Drive Status</b>						
16-30	DC Link Voltage	0 V	All set-ups	FALSE	0	UInt16
16-32	Brake Energy /s	0 kW	All set-ups	FALSE	0	UInt32
16-33	Brake Energy /2 min	0 kW	All set-ups	FALSE	0	UInt32
16-34	Heatsink Temp.	0 °C	All set-ups	FALSE	100	UInt8
16-35	Inverter Thermal	0 %	All set-ups	FALSE	0	UInt8
16-36	Inv. Nom. Current	ExpressionLimit	All set-ups	FALSE	-2	UInt32
16-37	Inv. Max. Current	ExpressionLimit	All set-ups	FALSE	-2	UInt32
16-38	SL Controller State	0 N/A	All set-ups	FALSE	0	UInt8
16-39	Control Card Temp.	0 °C	All set-ups	FALSE	100	UInt8
16-40	Logging Buffer Full	[0] No	All set-ups	TRUE	-	UInt8
16-41	LCP Bottom Statusline	0 N/A	All set-ups	TRUE	0	VisStr[50]
<b>16-5* Ref. &amp; Feedb.</b>						
16-50	External Reference	0 N/A	All set-ups	FALSE	-1	Int16
16-52	Feedback[Unit]	0 ProcessCtrlUnit	All set-ups	FALSE	-3	Int32
16-53	Digi Pot Reference	0 N/A	All set-ups	FALSE	-2	Int16
16-54	Feedback 1 [Unit]	0 ProcessCtrlUnit	All set-ups	FALSE	-3	Int32
16-55	Feedback 2 [Unit]	0 ProcessCtrlUnit	All set-ups	FALSE	-3	Int32
16-56	Feedback 3 [Unit]	0 ProcessCtrlUnit	All set-ups	FALSE	-3	Int32
<b>16-6* Inputs &amp; Outputs</b>						
16-60	Digital Input	0 N/A	All set-ups	FALSE	0	UInt16
16-61	Terminal 53 Switch Setting	[0] Current	All set-ups	FALSE	-	UInt8
16-62	Analog Input 53	0 N/A	All set-ups	FALSE	-3	Int32
16-63	Terminal 54 Switch Setting	[0] Current	All set-ups	FALSE	-	UInt8
16-64	Analog Input 54	0 N/A	All set-ups	FALSE	-3	Int32
16-65	Analog Output 42 [mA]	0 N/A	All set-ups	FALSE	-3	Int16
16-66	Digital Output [bin]	0 N/A	All set-ups	FALSE	0	Int16
16-67	Pulse Input #29 [Hz]	0 N/A	All set-ups	FALSE	0	Int32
16-68	Pulse Input #33 [Hz]	0 N/A	All set-ups	FALSE	0	Int32
16-69	Pulse Output #27 [Hz]	0 N/A	All set-ups	FALSE	0	Int32
16-70	Pulse Output #29 [Hz]	0 N/A	All set-ups	FALSE	0	Int32

## Parameter Descriptions

Par. No. #	Parameter description	Default value	4-set-up	Change during operation	Conversion index	Type
16-71	Relay Output [bin]	0 N/A	All set-ups	FALSE	0	Int16
16-72	Counter A	0 N/A	All set-ups	TRUE	0	Int32
16-73	Counter B	0 N/A	All set-ups	TRUE	0	Int32
16-75	Analog In X30/11	0 N/A	All set-ups	FALSE	-3	Int32
16-76	Analog In X30/12	0 N/A	All set-ups	FALSE	-3	Int32
16-77	Analog Out X30/8 [mA]	0 N/A	All set-ups	FALSE	-3	Int16
<b>16-8* Fieldbus &amp; FC Port</b>						
16-80	Fieldbus CTW 1	0 N/A	All set-ups	FALSE	0	V2
16-82	Fieldbus REF 1	0 N/A	All set-ups	FALSE	0	N2
16-84	Comm. Option STW	0 N/A	All set-ups	FALSE	0	V2
16-85	FC Port CTW 1	0 N/A	All set-ups	FALSE	0	V2
16-86	FC Port REF 1	0 N/A	All set-ups	FALSE	0	N2
<b>16-9* Diagnosis Readouts</b>						
16-90	Alarm Word	0 N/A	All set-ups	FALSE	0	Uint32
16-91	Alarm Word 2	0 N/A	All set-ups	FALSE	0	Uint32
16-92	Warning Word	0 N/A	All set-ups	FALSE	0	Uint32
16-93	Warning Word 2	0 N/A	All set-ups	FALSE	0	Uint32
16-94	Ext. Status Word	0 N/A	All set-ups	FALSE	0	Uint32
16-95	Ext. Status Word 2	0 N/A	All set-ups	FALSE	0	Uint32
16-96	Maintenance Word	0 N/A	All set-ups	FALSE	0	Uint32

## Parameter Descriptions

### 6.16.13 25-\*\* Cascade Pack Controller

6

Par. No. #	Parameter description	Default value	4-set-up	Change during operation	Conversion index	Type
<b>25-0* System Settings</b>						
25-00	Pack Controller	[0] Disabled	2 set-ups	FALSE	-	UInt8
25-04	Compressor Cycling	[0] Disabled	All set-ups	TRUE	-	UInt8
25-06	Number of Compressors	2 N/A	2 set-ups	FALSE	0	UInt8
<b>25-2* Zone Settings</b>						
25-20	Neutral Zone [unit]	4 ReferenceFeedbackUnit	All set-ups	TRUE	-2	UInt32
25-21	+ Zone [unit]	3 ReferenceFeedbackUnit	All set-ups	TRUE	-2	UInt32
25-22	- Zone [unit]	3 ReferenceFeedbackUnit	All set-ups	TRUE	-2	UInt32
25-23	Fixed Speed neutral Zone [unit]	4 ReferenceFeedbackUnit	All set-ups	TRUE	-2	UInt32
25-24	+ Zone Delay	120 s	All set-ups	TRUE	0	UInt32
25-25	- Zone Delay	60 s	All set-ups	TRUE	0	UInt32
25-26	++ Zone Delay	60 s	All set-ups	TRUE	0	UInt32
25-27	-- Zone Delay	30 s	All set-ups	TRUE	0	UInt32
<b>25-3* Staging Functions</b>						
25-30	Destage At No-Flow	[0] Disabled	All set-ups	TRUE	-	UInt8
25-31	Stage Function	[0] Disabled	All set-ups	TRUE	-	UInt8
25-32	Stage Function Time	15 s	All set-ups	TRUE	0	UInt16
25-33	Destage Function	[0] Disabled	All set-ups	TRUE	-	UInt8
25-34	Destage Function Time	15 s	All set-ups	TRUE	0	UInt16
<b>25-4* Staging Settings</b>						
25-42	Staging Threshold	ExpressionLimit	All set-ups	TRUE	0	UInt8
25-43	Destaging Threshold	ExpressionLimit	All set-ups	TRUE	0	UInt8
25-44	Staging Speed [RPM]	0 RPM	All set-ups	TRUE	67	UInt16
25-45	Staging Speed [Hz]	0 Hz	All set-ups	TRUE	-1	UInt16
25-46	Destaging Speed [RPM]	0 RPM	All set-ups	TRUE	67	UInt16
25-47	Destaging Speed [Hz]	0 Hz	All set-ups	TRUE	-1	UInt16
<b>25-8* Status</b>						
25-80	Pack Status	0 N/A	All set-ups	TRUE	0	VisStr[25]
25-81	Compressor Status	0 N/A	All set-ups	TRUE	0	VisStr[25]
25-82	Lead Compressor	0 N/A	All set-ups	TRUE	0	UInt8
25-83	Relay Status	0 N/A	All set-ups	TRUE	0	VisStr[4]
25-84	Compressor ON Time	0 h	All set-ups	TRUE	74	UInt32
25-85	Relay ON Time	0 h	All set-ups	TRUE	74	UInt32
25-86	Reset Relay Counters	[0] Do not reset	All set-ups	TRUE	-	UInt8
25-87	Inverse Interlock	0 N/A	All set-ups	TRUE	0	UInt16
25-88	Pack capacity [%]	0 %	All set-ups	TRUE	0	UInt16
<b>25-9* Service</b>						
25-90	Compressor Interlock	[0] Off	All set-ups	TRUE	-	UInt8
25-91	Manual Alternation	0 N/A	All set-ups	TRUE	0	UInt8

Par. No. #	Parameter description	Default value	4-set-up	Change during operation	Conversion index	Type
<b>28-0* Short Cycle Protection</b>						
28-00	Short Cycle Protection	[1] Disabled	All set-ups	TRUE	-	UInt8
28-01	Interval between Starts	300 s	All set-ups	TRUE	0	UInt16

## Parameter Descriptions

28-02	Minimum Run Time	12 s	All set-ups	TRUE	0	Uint16
<b>28-1* Oil Return Management</b>						
28-10	Oil Return Management	[0] Off	All set-ups	FALSE	-	Uint8
28-11	Low Speed Running Time	60 min	All set-ups	TRUE	70	Uint16
28-12	Fixed Boost Interval	24 h	All set-ups	TRUE	74	Uint8
28-13	Boost Duration	30 s	All set-ups	FALSE	0	Uint8
<b>28-2* Discharge Temperature Monitor</b>						
28-20	Temperature Source	[0] None	All set-ups	FALSE	-	Uint8
28-21	Temperature Unit	[60] °C	All set-ups	FALSE	-	Uint8
28-24	Warning Level	130 N/A	All set-ups	FALSE	0	Uint16
28-25	Warning Action	[1] Decrease cooling	All set-ups	FALSE	-	Uint8
28-26	Emergency Level	145 N/A	All set-ups	FALSE	0	Uint16
28-27	Discharge Temperature	0 DTM_ReadoutUnit	All set-ups	TRUE	0	Int32
<b>28-3* Crankcase Heating</b>						
28-30	Crankcase Heating Control	[0] Disabled	All set-ups	TRUE	-	Uint8
28-31	Heating DC Current	ExpressionLimit	All set-ups	TRUE	0	Uint8
28-32	Crankcase Heating Delay	5 s	All set-ups	TRUE	0	Uint16
<b>28-4* Anti-reverse Protection at Stop</b>						
28-40	Reverse Protection Control	[0] Disabled	All set-ups	TRUE	-	Uint8
28-41	DC Brake Current	90 %	All set-ups	TRUE	0	Uint16
28-42	DC Braking Time	ExpressionLimit	All set-ups	TRUE	-1	Uint16
28-43	DC Brake Cut In Speed [RPM]	ExpressionLimit	All set-ups	TRUE	67	Uint16
28-44	DC Brake Cut In Speed [Hz]	ExpressionLimit	All set-ups	TRUE	-1	Uint16
<b>28-5* Load Profile</b>						
28-50	Reset Load Profile	[0] Do not reset	All set-ups	TRUE	-	Uint8
28-59	Load Profile Data	0 N/A	All set-ups	TRUE	0	Uint16
<b>28-7* Day/Night Settings</b>						
28-74	Night Speed Drop [RPM]	ExpressionLimit	All set-ups	TRUE	67	Uint16
28-76	Night Speed Drop [Hz]	ExpressionLimit	All set-ups	TRUE	-1	Uint16

## 7 Troubleshooting

### 7.1 Status Messages

#### 7.1.1 Warnings/Alarm Messages

A warning or an alarm is signalled by the relevant LED on the front of the frequency converter and indicated by a code on the display.

A warning remains active until its cause is no longer present. Under certain circumstances, operation of the motor may still be continued. Warning messages may be critical, but are not necessarily so.

In the event of an alarm, the frequency converter trips. Reset the alarm to resume operation once the cause has been rectified.

##### Three ways to reset:

- Press [Reset].
- Via a digital input with the "Reset" function.
- Via serial communication/optional fieldbus.

#### **NOTICE**

After a manual reset pressing [Reset], press [Auto On] to restart the motor.

If an alarm cannot be reset, the reason may be that its cause has not been rectified, or the alarm is trip-locked (see also *Table 7.1*).

Alarms that are trip-locked offer additional protection, meaning that the mains supply must be switched off before the alarm can be reset. After being switched back on, the frequency converter is no longer blocked and can be reset as described above once the cause has been rectified.

Alarms that are not trip-locked can also be reset using the automatic reset function in *14-20 Reset Mode* (Warning: automatic wake-up is possible!)

If a warning or alarm is marked against a code in *Table 7.1*, this means that either a warning occurs before an alarm, or else that it is possible to specify whether a warning or an alarm should be displayed for a given fault.

This is possible, for instance, in *1-90 Motor Thermal Protection*. After an alarm or trip, the motor carries on coasting, and the alarm and warning flash. Once the problem has been rectified, only the alarm continues flashing until the frequency converter is reset.

#### **NOTICE**

No missing motor phase detection (numbers 30-32) and no stall detection is active when *1-10 Motor Construction* is set to [1] *PM non salient SPM*.

## Troubleshooting

No.	Description	Warning	Alarm/Trip	Alarm/Trip Lock	Parameter Reference
1	10 Volts low	X			
2	Live zero error	(X)	(X)		6-01 Live Zero Timeout Function
3	No motor	(X)			1-80 Function at Stop
4	Mains phase loss	(X)	(X)	(X)	14-12 Function at Mains Imbalance
5	DC link voltage high	X			
6	DC link voltage low	X			
7	DC over-voltage	X	X		
8	DC under voltage	X	X		
9	Inverter overloaded	X	X		
10	Motor ETR over temperature	(X)	(X)		1-90 Motor Thermal Protection
11	Motor thermistor over temperature	(X)	(X)		1-90 Motor Thermal Protection
12	Torque limit	X	X		
13	Over Current	X	X	X	
14	Earth Fault	X	X		
15	Hardware mismatch		X	X	
16	Short Circuit		X	X	
17	Control word time-out	(X)	(X)		Parameter 8-04 Control Word Timeout Function
18	Start failed		X		Parameter 4-18 Current Limit
20	Temp. Input Error		X		
21	Param Error			X	
22	Hoist Mech. Brake	(X)	(X)		Parameter group 2-2*
23	Internal Fans	X			
24	External Fans	X			
25	Brake resistor short-circuited	X			
26	Brake resistor power limit	(X)	(X)		2-13 Brake Power Monitoring
27	Brake chopper short-circuited	X	X		
28	Brake check	(X)	(X)		2-15 Brake Check
29	Heatsink temp	X	X	X	
30	Motor phase U missing	(X)	(X)	(X)	4-58 Missing Motor Phase Function
31	Motor phase V missing	(X)	(X)	(X)	4-58 Missing Motor Phase Function
32	Motor phase W missing	(X)	(X)	(X)	4-58 Missing Motor Phase Function
33	Inrush Fault		X	X	
34	Fieldbus communication fault	X	X		
35	Option Fault			X	
36	Mains failure	X	X		
37	Phase imbalance		X		
38	Internal Fault		X	X	
39	Heatsink sensor		X	X	
40	Overload of Digital Output Terminal 27	(X)			5-00 Digital I/O Mode, 5-01 Terminal 27 Mode
41	Overload of Digital Output Terminal 29	(X)			5-00 Digital I/O Mode, 5-02 Terminal 29 Mode



## Troubleshooting

No.	Description	Warning	Alarm/Trip	Alarm/Trip Lock	Parameter Reference
42	Ovrlid X30/6-7	(X)			
43	Ext. Supply (option)	X			
45	Earth Fault 2	X	X		
46	Pwr. card supply		X	X	
47	24 V supply low	X	X	X	
48	1.8 V supply low		X	X	
49	Speed limit		X		1-86 Trip Speed Low [RPM] , Parameter 4-18 Current Limit
50	AMA calibration failed		X		
51	AMA check $U_{nom}$ and $I_{nom}$		X		
52	AMA low $I_{nom}$		X		
53	AMA motor too big		X		
54	AMA motor too small		X		
55	AMA parameter out of range		X		
56	AMA interrupted by user		X		
57	AMA time-out		X		
58	AMA internal fault	X	X		
59	Current limit	X			
60	External Interlock	X	X		
61	Feedback Error	(X)	(X)		4-30 Motor Feedback Loss Function
62	Output Frequency at Maximum Limit	X			
63	Mechanical Brake Low		(X)		2-20 Release Brake Current
64	Voltage Limit	X			
65	Control Board Over-temperature	X	X	X	
66	Heat sink Temperature Low	X			
67	Option Configuration has Changed		X		
68	Safe Stop	(X)	(X) <sup>1)</sup>		5-19 Terminal 37 Safe Stop
69	Pwr. Card Temp		X	X	
70	Illegal FC configuration			X	
71	PTC 1 Safe Stop		X		
72	Dangerous failure			X	
73	Safe Stop Auto Restart	(X)	(X)		5-19 Terminal 37 Safe Stop
74	PTC Thermistor			X	
75	Illegal Profile Sel.		X		
76	Power Unit Setup	X			
77	Reduced power mode	X			14-59 Actual Number of Inverter Units
78	Tracking Error	(X)	(X)		4-34 Tracking Error Function
79	Illegal PS config		X	X	
80	Drive Initialized to Default Value		X		
81	CSIV corrupt		X		
82	CSIV parameter error		X		
83	Illegal Option Combination			X	
84	No Safety Option		X		
88	Option Detection			X	

## Troubleshooting

No.	Description	Warning	Alarm/Trip	Alarm/Trip Lock	Parameter Reference
89	Mechanical Brake Sliding	X			
90	Feedback Monitor	(X)	(X)		17-61 Feedback Signal Monitoring
91	Analog input 54 wrong settings			X	S202
99	Locked rotor		X	X	
104	Mixing Fans	X	X		
122	Mot. rotat. unexp.		X		
123	Motor Mod. Changed		X		
163	ATEX ETR cur.lim.warning	X			
164	ATEX ETR cur.lim.alarm		X		
165	ATEX ETR freq.lim.warning	X			
166	ATEX ETR freq.lim.alarm		X		
246	Pwr.card supply			X	
250	New spare part			X	
251	New Type Code		X	X	

**Table 7.1 Alarm/Warning Code List**

(X) Dependent on parameter

1) Cannot be Auto reset via 14-20 Reset Mode

A trip is the action following an alarm. The trip coasts the motor and is reset by pressing [Reset] or by a digital input (parameter group 5-1\* *Digital Inputs* [1]). The origin event that caused an alarm cannot damage the frequency converter or cause dangerous conditions. A trip lock is an action when an alarm occurs, which could damage the frequency converter or connected parts. A trip lock situation can only be reset by a power cycling.

Warning	yellow
Alarm	flashing red
Trip locked	yellow and red

**Table 7.2 LED Indication**

Bit	Hex	Dec	Alarm Word	Alarm Word 2	Warning Word	Warning Word 2	Extended Status Word	Extended Status Word 2
<b>Alarm Word Extended Status Word</b>								
0	00000001	1	Brake Check (A28)	ServiceTrip, Read/Write	Brake Check (W28)	Start Delayed	Ramping	Off
1	00000002	2	Pwr.card temp (A69)	ServiceTrip, (reserved)	Pwr.card temp (A69)	Stop Delayed	AMA Running	Hand/Auto
2	00000004	4	Earth Fault (A14)	ServiceTrip, Typecode/ Sparepart	Earth Fault (W14)	reserved	Start CW/CCW start_possible is active, when the DI selections [12] OR [13] are active and the requested direction matches the reference sign	Profibus OFF1 active
3	00000008	8	Ctrl.Card Temp (A65)	ServiceTrip, (reserved)	Ctrl.Card Temp (W65)	reserved	Slow Down slow down command active, e.g. via CTW bit 11 or DI	Profibus OFF2 active
4	00000010	16	Ctrl. Word TO (A17)	ServiceTrip, (reserved)	Ctrl. Word TO (W17)		Catch Up catch up command active, e.g. via CTW bit 12 or DI	Profibus OFF3 active
5	00000020	32	Over Current (A13)	reserved	Over Current (W13)	reserved	Feedback High feedback > 4-57	Relay 123 active

## Troubleshooting

Bit	Hex	Dec	Alarm Word	Alarm Word 2	Warning Word	Warning Word 2	Extended Status Word	Extended Status Word 2
6	00000040	64	Torque Limit (A12)	reserved	Torque Limit (W12)	reserved	Feedback Low feedback < 4-56	Start Prevented
7	00000080	128	Motor Th Over (A11)	reserved	Motor Th Over (W11)	reserved	Output Current High current > 4-51	Control Ready
8	00000100	256	Motor ETR Over (A10)	reserved	Motor ETR Over (W10)	reserved	Output Current Low current < 4-50	Drive Ready
9	00000200	512	Inverter Overld. (A9)	Discharge High	Inverter Overld (W9)	Discharge High	Output Freq High speed > 4-53	Quick Stop
10	00000400	1024	DC under Volt (A8)	Start Failed	DC under Volt (W8)	Multi-motor underload	Output Freq Low speed < 4-52	DC Brake
11	00000800	2048	DC over Volt (A7)	Speed Limit	DC over Volt (W7)	Multi-motor Overload	Brake Check OK brake test NOT ok	Stop
12	00001000	4096	Short Circuit (A16)	External Interlock	DC Voltage Low (W6)	Compressor Interlock	Braking Max BrakePower > BrakePowerLimit (2-12)	Stand by
13	00002000	8192	Inrush Fault (A33)	Illegal Option Combi.	DC Voltage High (W5)	Mechanical Brake Sliding	Braking	Freeze Output Request
14	00004000	16384	Mains ph. Loss (A4)	No Safety Option	Mains ph. Loss (W4)	Safe Option Warning	Out of Speed Range	Freeze Output
15	00008000	32768	AMA Not OK	reserved	No Motor (W3)	Auto DC Braking	OVC Active	Jog Request
16	00010000	65536	Live Zero Error (A2)	reserved	Live Zero Error (W2)		AC Brake	Jog
17	00020000	131072	Internal Fault (A38)	KTY error	10V Low (W1)	KTY Warn	Password Timelock number of allowed password trials exceeded - timelock active	Start Request
18	00040000	262144	Brake Overload (A26)	Fans error	Brake Overload (W26)	Fans Warn	Password Protection 0-61 = ALL_NO_ACCESS OR BUS_NO_ACCESS OR BUS_READONLY	Start
19	00080000	524288	U phase Loss (A30)	ECB error	Brake Resistor (W25)	ECB Warn	Reference High reference > 4-55	Start Applied
20	00100000	1048576	V phase Loss (A31)	Hoist mechanical brake (A22)	Brake IGBT (W27)	Hoist mechanical brake (W22)	Reference Low reference < 4-54	Start delay
21	00200000	2097152	W phase Loss (A32)	reserved	Speed Limit (W49)	reserved	Local Reference reference site = REMOTE - > auto on pressed & active	Sleep
22	00400000	4194304	Fieldbus Fault (A34)	reserved	Fieldbus Fault (W34)	reserved	Protection mode notification	Sleep Boost
23	00800000	8388608	24 V Supply Low (A47)	reserved	24V Supply Low (W47)	reserved	Unused	Running
24	01000000	16777216	Mains Failure (A36)	reserved	Mains Failure (W36)	reserved	Unused	Drive Bypass
25	02000000	33554432	1.8V Supply Low (A48)	Current Limit (A59)	Current Limit (W59)	reserved	Unused	Fire Mode
26	04000000	67108864	Brake Resistor (A25)	Motor Rotating Unexpectedly (A122)	Low Temp (W66)	reserved	Unused	External Interlock
27	08000000	134217728	Brake IGBT (A27)	reserved	Voltage Limit (W64)	reserved	Unused	Firemode Limit Exceed

## Troubleshooting

Bit	Hex	Dec	Alarm Word	Alarm Word 2	Warning Word	Warning Word 2	Extended Status Word	Extended Status Word 2
28	10000000	268435456	Option Change (A67)	reserved	Encoder loss (W90)	reserved	Unused	Flying Start active
29	20000000	536870912	Drive Initialised (A80)	Encoder loss (A90)	Output freq. lim. (W62)	BackEMF too High	Unused	
30	40000000	1073741824	Safe Stop (A68)	PTC Thermi-stor (A74)	Safe Stop (W68)	PTC Thermi-stor (W74)	Unused	
31	80000000	2147483648	Mech. brake low (A63)	Dangerous failure (A72)	Extended Status Word		Protection Mode	

Table 7.3 Description of Alarm Word, Warning Word and Extended Status Word

The alarm words, warning words and extended status words can be read out via serial bus or optional fieldbus for diagnostics. See also *parameter 16-94 Ext. Status Word*.

### WARNING 1, 10 Volts low

The control card voltage is below 10 V from terminal 50. Remove some of the load from terminal 50, as the 10 V supply is overloaded. Max. 15 mA or minimum 590  $\Omega$ .

A short circuit in a connected potentiometer or improper wiring of the potentiometer can cause this condition.

#### Troubleshooting

- Remove the wiring from terminal 50. If the warning clears, the problem is with the wiring. If the warning does not clear, replace the control card.

### WARNING/ALARM 2, Live zero error

This warning or alarm only appears if programmed in *6-01 Live Zero Timeout Function*. The signal on one of the analog inputs is less than 50% of the minimum value programmed for that input. Broken wiring or faulty device sending the signal can cause this condition.

#### Troubleshooting

- Check connections on all the analog input terminals. Control card terminals 53 and 54 for signals, terminal 55 common. MCB 101 terminals 11 and 12 for signals, terminal 10 common. MCB 109 terminals 1, 3, 5 for signals, terminals 2, 4, 6 common.
- Check that the frequency converter programming and switch settings match the analog signal type.
- Perform input terminal signal test.

### WARNING/ALARM 3, No motor

No motor has been connected to the output of the frequency converter.

### WARNING/ALARM 4, Mains phase loss

A phase is missing on the supply side, or the mains voltage imbalance is too high. This message also appears for a fault in the input rectifier on the frequency converter. Options are programmed at *14-12 Function at Mains Imbalance*.

#### Troubleshooting

- Check the supply voltage and supply currents to the frequency converter.

### WARNING 5, DC link voltage high

The intermediate circuit voltage (DC) is higher than the high-voltage warning limit. The limit is dependent on the frequency converter voltage rating. The unit is still active.

### WARNING 6, DC link voltage low

The intermediate circuit voltage (DC) is lower than the low-voltage warning limit. The limit is dependent on the frequency converter voltage rating. The unit is still active.

### WARNING/ALARM 7, DC overvoltage

If the intermediate circuit voltage exceeds the limit, the frequency converter trips after a time.

#### Troubleshooting

- Connect a brake resistor
- Extend the ramp time
- Change the ramp type
- Activate the functions in *2-10 Brake Function*
- Increase *14-26 Trip Delay at Inverter Fault*
- If the alarm/warning occurs during a power sag, use kinetic back-up (*14-10 Mains Failure*)

### WARNING/ALARM 8, DC under voltage

If the DC-link voltage drops below the undervoltage limit, the frequency converter checks if a 24 V DC backup supply is connected. If no 24 V DC backup supply is connected, the frequency converter trips after a fixed time delay. The time delay varies with unit size.

#### Troubleshooting

- Check that the supply voltage matches the frequency converter voltage.
- Perform input voltage test.
- Perform soft charge circuit test.

### WARNING/ALARM 9, Inverter overload

The frequency converter is about to cut out because of an overload (too high current for too long). The counter for electronic, thermal inverter protection issues a warning at 98% and trips at 100%, while giving an alarm. The frequency converter cannot be reset until the counter is below 90%.

## Troubleshooting

The fault is that the frequency converter has run with more than 100% overload for too long.

### Troubleshooting

- Compare the output current shown on the keypad with the frequency converter rated current.
- Compare the output current shown on the keypad with measured motor current.
- Display the thermal drive load on the keypad and monitor the value. When running above the frequency converter continuous current rating, the counter increases. When running below the frequency converter continuous current rating, the counter decreases.

### WARNING/ALARM 10, Motor overload temperature

According to the electronic thermal protection (ETR), the motor is too hot. Select whether the frequency converter issues a warning or an alarm when the counter reaches 100% in *1-90 Motor Thermal Protection*. The fault occurs when the motor runs with more than 100% overload for too long.

### Troubleshooting

- Check for motor overheating.
- Check if the motor is mechanically overloaded
- Check that the motor current set in *1-24 Motor Current* is correct.
- Ensure that Motor data in parameters 1-20 to 1-25 are set correctly.
- If an external fan is in use, check in *1-91 Motor External Fan* that it is selected.
- Running AMA in *1-29 Automatic Motor Adaptation (AMA)* tunes the frequency converter to the motor more accurately and reduces thermal loading.

### WARNING/ALARM 11, Motor thermistor over temp

Check whether the thermistor is disconnected. Select whether the frequency converter issues a warning or an alarm in *1-90 Motor Thermal Protection*.

## WARNING

Live Electrical Components!

### Troubleshooting

- Check for motor overheating.
- Check if the motor is mechanically overloaded.
- When using terminal 53 or 54, check that the thermistor is connected correctly between either terminal 53 or 54 (analog voltage input) and terminal 50 (+10 V supply). Also check that the terminal switch for 53 or 54 is set for voltage.

Check *1-93 Thermistor Source* selects terminal 53 or 54.

- When using digital inputs 18 or 19, check that the thermistor is connected correctly between either terminal 18 or 19 (digital input PNP only) and terminal 50. Check *1-93 Thermistor Source* selects terminal 18 or 19.

## WARNING

Disconnect power before proceeding.

### WARNING/ALARM 12, Torque limit

The torque has exceeded the value in *4-16 Torque Limit Motor Mode* or the value in *4-17 Torque Limit Generator Mode*. *14-25 Trip Delay at Torque Limit* can change this warning from a warning-only condition to a warning followed by an alarm.

### Troubleshooting

- If the motor torque limit is exceeded during ramp up, extend the ramp up time.
- If the generator torque limit is exceeded during ramp down, extend the ramp down time.
- If torque limit occurs while running, possibly increase the torque limit. Make sure that the system can operate safely at a higher torque.
- Check the application for excessive current draw on the motor.

### WARNING/ALARM 13, Over current

The inverter peak current limit (approximately 200% of the rated current) is exceeded. The warning lasts about 1.5 s, then the frequency converter trips and issues an alarm. Shock loading or quick acceleration with high inertia loads can cause this fault. If the acceleration during ramp up is quick, the fault can also appear after kinetic back-up. If extended mechanical brake control is selected, trip can be reset externally.

### Troubleshooting

- Remove power and check if the motor shaft can be turned.
- Check that the motor size matches the frequency converter.
- Check parameters 1-20 to 1-25 for correct motor data.

### ALARM 14, Earth (ground) fault

There is current from the output phases to ground, either in the cable between the frequency converter and the motor or in the motor itself.

## Troubleshooting

### Troubleshooting

- Remove power to the frequency converter and repair the ground fault.
- Check for ground faults in the motor by measuring the resistance to ground of the motor leads and the motor with a megohmmeter.

### **⚠ WARNING**

Disconnect power before proceeding.

#### ALARM 15, Hardware mismatch

A fitted option is not operational with the present control board hardware or software.

Record the value of the following parameters and contact Trane:

- 15-40 FC Type
- 15-41 Power Section
- 15-42 Voltage
- 15-43 Software Version
- 15-45 Actual Typecode String
- 15-49 SW ID Control Card
- 15-50 SW ID Power Card
- 15-60 Option Mounted
- 15-61 Option SW Version (for each option slot)

#### ALARM 16, Short circuit

There is short-circuiting in the motor or motor wiring.

### Troubleshooting

- Remove power to the frequency converter and repair the short circuit.

### **⚠ WARNING**

Disconnect power before proceeding.

#### WARNING/ALARM 17, Control word timeout

There is no communication to the frequency converter.

The warning is only active when *parameter 8-04 Control Word Timeout Function* is NOT set to [0] Off.

If *parameter 8-04 Control Word Timeout Function* is set to [5] Stop and Trip, a warning appears and the frequency converter ramps down until it stops then displays an alarm.

### **⚠ WARNING**

Live Electrical Components!

### Troubleshooting

- Check connections on the serial communication cable.
- Increase 8-03 Control Word Timeout Time.
- Check the operation of the communication equipment.

- Verify a proper installation based on EMC requirements.

#### ALARM 18, Start failed

The speed has not exceeded *1-77 Compressor Start Max Speed [RPM]* during start within the allowed time. (set in *1-79 Compressor Start Max Time to Trip*). This may be caused by a blocked motor.

#### Warning/Alarm 19, Discharge Temperature High

Warning:

The discharge temperature exceeds the level programmed in *28-25 Warning Level*.

Alarm:

The discharge temperature exceeds the level programmed in *28-26 Emergency Level*.

#### WARNING/ALARM 20, Temp. input error

The temperature sensor is not connected.

#### WARNING/ALARM 21, Parameter error

The parameter is out of range. The parameter number is reported in the keypad.

### Troubleshooting

- The affected parameter must be set to a valid value.

#### WARNING/ALARM 22, Hoist mechanical brake

Report value shows what kind it is.

0 = The torque ref. was not reached before time out (*2-27 Torque Ramp Up Time*).

1 = Expected brake feedback not received before time out (*2-23 Activate Brake Delay, 2-25 Brake Release Time*).

#### WARNING 23, Internal fan fault

The fan warning function is an extra protective function that checks if the fan is running/mounted. The fan warning can be disabled in *14-53 Fan Monitor ([0] Disabled)*.

For the D, E, and F-frame filters, the regulated voltage to the fans is monitored.

### Troubleshooting

- Check for proper fan operation.
- Cycle power to the frequency converter and check that the fan operates briefly at start-up.
- Check the sensors on the heat sink and control card.

#### WARNING 24, External fan fault

The fan warning function is an extra protective function that checks if the fan is running/mounted. The fan warning can be disabled in *14-53 Fan Monitor ([0] Disabled)*.

### Troubleshooting

- Check for proper fan operation.
- Cycle power to the frequency converter and check that the fan operates briefly at start-up.
- Check the sensors on the heat sink and control card.

**WARNING/ALARM 28, Brake check failed**

The brake resistor is not connected or not working. Check 2-15 *Brake Check*.

**ALARM 29, Heat Sink temp**

The maximum temperature of the heat sink has been exceeded. The temperature fault does not reset until the temperature falls below a defined heatsink temperature. The trip and reset points are different based on the frequency converter power size.

**Troubleshooting**

Check for the following conditions.

- Ambient temperature too high.
- Motor cable too long.
- Incorrect airflow clearance above and below the frequency converter.
- Blocked airflow around the frequency converter.
- Damaged heatsink fan.
- Dirty heat sink.

**ALARM 30, Motor phase U missing**

Motor phase U between the frequency converter and the motor is missing.

**⚠ WARNING**

**Disconnect power before proceeding.**

Remove power from the frequency converter and check motor phase U.

**ALARM 31, Motor phase V missing**

Motor phase V between the frequency converter and the motor is missing.

**⚠ WARNING**

**Disconnect power before proceeding.**

Remove power from the frequency converter and check motor phase V.

**ALARM 32, Motor phase W missing**

Motor phase W between the frequency converter and the motor is missing.

**⚠ WARNING**

**Disconnect power before proceeding.**

Remove power from the frequency converter and check motor phase W.

**ALARM 33, Inrush fault**

Too many power-ups have occurred within a short time period. Let the unit cool to operating temperature.

**WARNING/ALARM 34, Fieldbus communication fault**

The fieldbus on the communication option card is not working.

**WARNING/ALARM 35, Option fault**

An option alarm is received. The alarm is option-specific. The most likely cause is a power-up or a communication fault.

**WARNING/ALARM 36, Mains failure**

This warning/alarm is only active if the supply voltage to the frequency converter is lost and *14-10 Mains Failure* is not set to [0] *No Function*. Check the fuses to the frequency converter and mains supply to the unit.

**ALARM 37, Phase imbalance**

There is a current imbalance between the power units

**ALARM 38, Internal fault**

When an internal fault occurs, a code number defined in *Table 7.4* is displayed.

**Troubleshooting**

- Cycle power
- Check that the option is properly installed
- Check for loose or missing wiring

It may be necessary to contact your Trane supplier or service department. Note the code number for further troubleshooting directions.

No.	Text
0	Serial port cannot be initialised. Contact your Trane supplier or Trane Service Department.
256-258	Power EEPROM data is defective or too old. Replace power card.
512-519	Internal fault. Contact your Trane supplier or Trane Service Department.
783	Parameter value outside of min/max limits
1024-1284	Internal fault. Contact your Trane supplier or the Trane Service Department.
1299	Option SW in slot A is too old
1300	Option SW in slot B is too old
1302	Option SW in slot C1 is too old
1315	Option SW in slot A is not supported (not allowed)
1316	Option SW in slot B is not supported (not allowed)
1318	Option SW in slot C1 is not supported (not allowed)
1379-2819	Internal fault. Contact your Trane supplier or Trane Service Department.
1792	HW reset of DSP
1793	Motor derived parameters not transferred correctly to DSP
1794	Power data not transferred correctly at power up to DSP
1795	The DSP has received too many unknown SPI telegrams
1796	RAM copy error
2561	Replace control card
2820	LCP stack overflow
2821	Serial port overflow
2822	USB port overflow

No.	Text
3072-5122	Parameter value is outside its limits
5123	Option in slot A: Hardware incompatible with control board hardware
5124	Option in slot B: Hardware incompatible with control board hardware
5125	Option in slot C0: Hardware incompatible with control board hardware
5126	Option in slot C1: Hardware incompatible with control board hardware
5376-6231	Internal fault. Contact your Trane supplier or Trane Service Department.

**Table 7.4 Internal Fault Codes**
**ALARM 39, Heat Sink sensor**

No feedback from the heat sink temperature sensor.

The signal from the IGBT thermal sensor is not available on the power card. The problem could be on the power card, on the gate drive card, or the ribbon cable between the power card and gate drive card.

**WARNING 40, Overload of digital output terminal 27**

Check the load connected to terminal 27 or remove short-circuit connection. Check *5-01 Terminal 27 Mode*.

**WARNING 41, Overload of digital output terminal 29**

Check the load connected to terminal 29 or remove short-circuit connection. Check *5-02 Terminal 29 Mode*.

**WARNING 42, Overload of digital output on X30/6 or overload of digital output on X30/7**

For X30/6, check the load connected to X30/6 or remove the short-circuit connection. Check *5-32 Term X30/6 Digi Out (MCB 101)*.

For X30/7, check the load connected to X30/7 or remove the short-circuit connection. Check *5-33 Term X30/7 Digi Out (MCB 101)*.

**ALARM 43, Ext. supply**

MCB 113 Ext. Relay Option is mounted without ext. 24 V DC. Either connect an ext. 24 V DC supply or specify that no external supply is used via *14-80 Option Supplied by External 24VDC* [0]. A change in *14-80 Option Supplied by External 24VDC* requires a power cycle.

**ALARM 45, Earth fault 2**

Ground fault.

**Troubleshooting**

- Check for proper grounding and loose connections.
- Check for proper wire size.
- Check motor cables for short-circuits or leakage currents.

**ALARM 46, Power card supply**

The supply on the power card is out of range.

There are 3 power supplies generated by the switch mode power supply (SMPS) on the power card: 24 V, 5 V,  $\pm 18$  V.

When powered with 24 V DC with the MCB 107 option, only the 24 V and 5 V supplies are monitored. When powered with 3-phase mains voltage, all 3 supplies are monitored.

**Troubleshooting**

- Check for a defective power card.
- Check for a defective control card.
- Check for a defective option card.
- If a 24 V DC power supply is used, verify proper supply power.

**WARNING 47, 24 V supply low**

The 24 Vdc is measured on the control card. This alarm arises when the detected voltage of terminal 12 is lower than 18 V.

**Troubleshooting**

- Check for a defective control card.

**WARNING 48, 1.8 V supply low**

The 1.8Vdc supply used on the control card is outside of allowable limits. The power supply is measured on the control card. Check for a defective control card. If an option card is present, check for an overvoltage condition.

**WARNING 49, Speed limit**

When the speed is not within the specified range in *4-11 Motor Speed Low Limit [RPM]* and *4-13 Motor Speed High Limit [RPM]*, the frequency converter shows a warning. When the speed is below the specified limit in *1-86 Trip Speed Low [RPM]* (except when starting or stopping), the frequency converter trips.

**ALARM 50, AMA calibration failed**

Contact Trane supplier or Trane service department.

**ALARM 51, AMA check  $U_{nom}$  and  $I_{nom}$** 

The settings for motor voltage, motor current and motor power are wrong. Check the settings in parameters 1-20 to 1-25.

**ALARM 52, AMA low  $I_{nom}$** 

The motor current is too low. Check the settings.

**ALARM 53, AMA motor too big**

The motor is too big for the AMA to operate.

**ALARM 54, AMA motor too small**

The motor is too small for the AMA to operate.

**ALARM 55, AMA parameter out of range**

The parameter values of the motor are outside of the acceptable range. AMA cannot run.

**ALARM 56, AMA interrupted by user**

The user has interrupted the AMA.

**ALARM 57, AMA internal fault**

Try to restart AMA again. Repeated restarts can over heat the motor.

**ALARM 58, AMA Internal fault**

Contact the Trane supplier.



**WARNING 59, Current limit**

The current is higher than the value in *4-18 Current Limit*. Ensure that motor data in parameters 1–20 to 1–25 are set correctly. Possibly increase the current limit. Be sure that the system can operate safely at a higher limit.

**WARNING 60, External interlock**

A digital input signal is indicating a fault condition external to the frequency converter. An external interlock has commanded the frequency converter to trip. Clear the external fault condition. To resume normal operation, apply 24 Vdc to the terminal programmed for external interlock. Reset the frequency converter.

**WARNING/ALARM 61, Feedback error**

An error between calculated speed and speed measurement from feedback device. The function Warning/Alarm/Disabling setting is in *4-30 Motor Feedback Loss Function*. Accepted error setting in *4-31 Motor Feedback Speed Error* and the allowed time the error occur setting in *4-32 Motor Feedback Loss Timeout*. During a commissioning procedure the function may be effective.

**WARNING 62, Output frequency at maximum limit**

The output frequency has reached the value set in *4-19 Max Output Frequency*. Check the application to determine the cause. Possibly increase the output frequency limit. Be sure the system can operate safely at a higher output frequency. The warning clears when the output drops below the maximum limit.

**ALARM 63, Mechanical brake low**

The actual motor current has not exceeded the release brake current within the start delay time window.

**WARNING/ALARM 65, Control card over temperature**

The cut-out temperature of the control card is 80 °C.

**Troubleshooting**

- Check that the ambient operating temperature is within limits
- Check for clogged filters
- Check fan operation
- Check the control card

**WARNING 66, Heat sink temperature low**

The frequency converter is too cold to operate. This warning is based on the temperature sensor in the IGBT module.

Increase the ambient temperature of the unit. Also, a trickle amount of current can be supplied to the frequency converter whenever the motor is stopped by setting *2-00 DC Hold/Preheat Current* at 5% and *1-80 Function at Stop*.

**ALARM 67, Option module configuration has changed**

One or more options have either been added or removed since the last power-down. Check that the configuration change is intentional and reset the unit.

**ALARM 69, Power card temperature**

The temperature sensor on the power card is either too hot or too cold.

**Troubleshooting**

- Check that the ambient operating temperature is within limits.
- Check for clogged filters.
- Check fan operation.
- Check the power card.

**ALARM 70, Illegal FC configuration**

The control card and power card are incompatible. To check compatibility, contact the Trane supplier with the type code of the unit from the nameplate and the part numbers of the cards.

**ALARM 71, PTC 1 safe stop**

Safe Torque Off has been activated from the PTC Thermistor Card (motor too warm). Normal operation can be resumed when the applies 24 V DC to Terminal 37 again (when the motor temperature reaches an acceptable level) and when the Digital Input from the is deactivated. When that happens, a reset signal must be is be sent (via Bus, Digital I/O, or by pressing [Reset]).

**ALARM 72, Dangerous failure**

Safe Torque Off with trip lock. An unexpected combination of Safe Torque Off commands has occurred:

- a PTC Thermistor Card enables X44/10, but safe stop is not enabled.
- is the only device using Safe Torque Off (specified through selection [4] or [5] in *5-19 Terminal 37 Safe Stop*), Safe Torque Off is activated, and X44/10 is not activated.

**WARNING 73, Safe Stop auto restart**

Safe stopped. With automatic restart enabled, the motor could start when the fault is cleared.

**ALARM 74, PTC Thermistor**

Alarm related to the ATEX option. The PTC is not working.

**ALARM 75, Illegal profile sel.**

Parameter value must not be written while motor is running. Stop motor before writing MCO profile to *8-10 Control Word Profile* for instance.

**WARNING 76, Power unit setup**

The required number of power units does not match the detected number of active power units.

**WARNING 77, Reduced power mode**

The frequency converter is operating in reduced power mode (less than the allowed number of inverter sections). This warning is generated on power cycle when the frequency converter is set to run with fewer inverters, and remains on.

**ALARM 78, Tracking error**

The difference between set point value and actual value has exceeded the value in *4-35 Tracking Error*. Disable the function by *4-34 Tracking Error Function* or select an alarm/warning also in *4-34 Tracking Error Function*. Investigate the mechanics around the load and motor, check feedback connections from motor – encoder – to frequency converter. Select motor feedback function in *4-30 Motor Feedback Loss Function*. Adjust tracking error band in *4-35 Tracking Error* and *4-37 Tracking Error Ramping*.

**ALARM 79, Illegal power section configuration**

The scaling card has an incorrect part number or is not installed. The MK102 connector on the power card could not be installed.

**ALARM 80, Drive initialised to default value**

Parameter settings are initialised to default settings after a manual reset. To clear the alarm, reset the unit.

**ALARM 81, CSIV corrupt**

CSIV file has syntax errors.

**ALARM 82, CSIV parameter error**

CSIV failed to init a parameter.

**ALARM 83, Illegal option combination**

The mounted options are incompatible.

**ALARM 84, No safety option**

The safety option was removed without applying a general reset. Reconnect the safety option.

**ALARM 88, Option detection**

A change in the option layout was detected. *14-89 Option Detection* is set to [0] *Frozen configuration* and the option layout has been changed.

- To apply the change, enable option layout changes in *14-89 Option Detection*.
- Alternatively, restore the correct option configuration.

**WARNING 89, Mechanical brake sliding**

The hoist brake monitor has detected a motor speed > 10 RPM.

**ALARM 90, Feedback monitor**

Check the connection to encoder/resolver option and eventually replace the MCB 102 or MCB 103.

**ALARM 91, Analog input 54 wrong settings**

Switch S202 has to be set in position OFF (voltage input) when a KTY sensor is connected to analog input terminal 54.

**WARNING/ALARM 104, Mixing fan fault**

The fan is not operating. The fan monitor checks that the fan is spinning at power-up or whenever the mixing fan is turned on. The mixing-fan fault can be configured as a warning or an alarm trip by *parameter 14-53 Fan Monitor*.

**Troubleshooting**

- Cycle power to the frequency converter to determine if the warning/alarm returns.

**WARNING 163, ATEX ETR cur.lim.warning**

The frequency converter has exceeded the characteristic curve for more than 50 s. The warning is activated at 83% and de-activated at 65% of the permitted thermal overload.

**ALARM 164, ATEX ETR cur.lim.alarm**

Operating above the characteristic curve for more than 60 s within a period of 600 s activates the alarm and the frequency converter trips.

**WARNING 165, ATEX ETR freq.lim.warning**

The frequency converter is running more than 50 s below the permitted minimum frequency (*1-98 ATEX ETR interp. points freq.* [0]).

**ALARM 166, ATEX ETR freq.lim.alarm**

The frequency converter has operated more than 60 s (in a period of 600 s) below the permitted minimum frequency (*1-98 ATEX ETR interp. points freq.* [0]).

**ALARM 246, Power card supply**

This alarm is only for F-frame frequency converters. It is equivalent to Alarm 46. The report value in the alarm log indicates which power module generated the alarm:

- 1 = left most inverter module.
- 2 = middle inverter module in F2 or F4 frequency converter.
- 2 = right inverter module in F1 or F3 frequency converter.
- 3 = right inverter module in F2 or F4 frequency converter.
- 5 = rectifier module.

**WARNING 250, New spare part**

A component in the frequency converter has been replaced. Reset the frequency converter for normal operation.

**WARNING 251, New typecode**

The power card or other components have been replaced and the typecode changed. Reset to remove the warning and resume normal operation.

## 8 General Specifications

### 8.1 Power-dependent Specifications

#### 8.1.1 Mains Supply 3x200-240 V AC

	P15K	P18K	P22K
Compressor model	VSH088/VZH088	VSH117/VZH117	VSH170/VZH170
Typical Shaft Output [kW]	18.5	22	30
Enclosure IP20	B4	C3	C3
Enclosure IP21, IP55, IP66	C1	C1	C1
<b>Output current</b>			
Continuous (3 x 200-240 V) [A]	74.8	88	115
Intermittent (60 s overload) (3 x 200-240 V) [A]	82.3	96.8	127
Continuous kVA (208 V AC) [kVA]	26.9	31.7	41.4
<b>Max. input current</b>			
Continuous (3 x 200-240 V) [A]	68	80	104
Intermittent (60 s overload) (3 x 200-240 V) [A]	74.8	88	114
<b>Additional specifications</b>			
IP20 max. cable cross-section <sup>5)</sup> (mains, brake, motor and load sharing)	35 (2)	50 (1)	50 (1)
IP21, IP55, IP66 max. cable cross-section <sup>5)</sup> (mains, motor, load sharing) [mm <sup>2</sup> (AWG)] <sup>2)</sup>	50 (1)	50 (1)	50 (1)
Max cable size with mains disconnect [mm <sup>2</sup> (AWG)] <sup>2)</sup>	50, 35, 35 (1, 2, 2)		
Estimated power loss at rated max. load [W] <sup>4)</sup>	737	845	1140
Weight, IP20 [kg]	23.5	50	50
Weight, IP21, IP55/IP66 [kg]	45	45	45
Efficiency <sup>4)</sup>	0.96	0.97	0.97

**Table 8.1 Mains Supply 3x200-240 V AC**

For fuse ratings, see chapter 3.4.1 Fuses

1) Normal overload = 110% torque during 60 s.

2) American Wire Gauge.

3) Measured using 5 m screened motor cables at rated load and rated frequency.

4) The typical power loss is at nominal load conditions and expected to be within  $\pm 15\%$  (tolerance relates to variety in voltage and cable conditions).

Values are based on a typical motor efficiency (eff2/eff3 border line). Motors with lower efficiency will also add to the power loss in the frequency converter and opposite.

If the switching frequency is increased compared to the default setting, the power losses may rise significantly.

Keypad and typical control card power consumptions are included. Further options and customer load may add up to 30 W to the losses. (Though typical only 4 W extra for a fully loaded control card, or options for slot A or slot B, each).

Although measurements are made with state of the art equipment, some measurement inaccuracy must be allowed for ( $\pm 5\%$ ).

5) The three values for the max. cable cross section are for single core, flexible wire and flexible wire with sleeve, respectively.

## General Specifications

### 8.1.2 Mains Supply 3x380-480 V AC

	P15K	P18K	P22K
Compressor model	VSH088/VZH088	VSH117/VZH117	VSH170/VZH170
Typical shaft output [kW]	18.5	22.0	30.0
Enclosure IP20	B3	B4	B4
Enclosure IP21, IP55, IP66	B1	B2	B2
<b>Output current</b>			
Continuous (3 x 380-440 V) [A]	37.5	44	61
Intermittent (60 s overload) (3 x 380-440 V) [A]	41.3	48.4	67.1
Continuous (3 x 441-500 V) [A]	34	40	52
Intermittent (60 s overload) (3 x 441-500 V) [A]	37.4	44	57.2
Continuous kVA (400 V AC) [kVA]	26	30.5	42.3
Continuous kVA (460 V AC) [kVA]	27.1	31.9	41.4
<b>Max. input current</b>			
Continuous (3 x 380-440 V) [A]	34	40	55
Intermittent (60 s overload) (3 x 380-440 V) [A]	37.4	44	60.5
Continuous (3 x 441-500 V) [A]	31	36	47
Intermittent (60 s overload) (3 x 441-500 V) [A]	34.1	39.6	51.7
<b>Additional specifications</b>			
IP21, IP55, IP66 max. cable cross-section <sup>5)</sup> (mains, brake, load sharing) [mm <sup>2</sup> (AWG)] <sup>2)</sup>	16, 10, 16 (6, 8, 6)	35,-,-(2,-,-)	35,-,-(2,-,-)
IP21, IP55, IP66 max. cable cross-section <sup>5)</sup> (motor) [mm <sup>2</sup> (AWG)] <sup>2)</sup>	10, 10,- (8, 8,-)	35, 25, 25 (2, 4, 4)	35, 25, 25 (2, 4, 4)
IP20 max. cable cross-section <sup>5)</sup> (mains, brake, motor and load sharing)	10, 10,- (8, 8,-)	35,-,-(2,-,-)	35,-,-(2,-,-)
Estimated power loss at rated max. load [W] <sup>4)</sup>	465	525	739
Weight, enclosure IP20 [kg]	12	23.5	23.5
Weight, enclosure IP21, IP55, IP66 [kg]	23	27	27
Efficiency <sup>4)</sup>	0.98	0.98	0.98

**Table 8.2 Mains Supply 3x380-480 V AC**

For fuse ratings, see chapter 3.4.1 Fuses

1) Normal overload = 110% torque during 60 s.

2) American Wire Gauge.

3) Measured using 5 m screened motor cables at rated load and rated frequency.

4) The typical power loss is at nominal load conditions and expected to be within  $\pm 15\%$  (tolerance relates to variety in voltage and cable conditions).

Values are based on a typical motor efficiency (eff2/eff3 border line). Motors with lower efficiency will also add to the power loss in the frequency converter and vice versa.

If the switching frequency is increased compared to the default setting, the power losses may rise significantly.

Keypad and typical control card power consumptions are included. Further options and customer load may add up to 30 W to the losses. (Though typical only 4 W extra for a fully loaded control card, or options for slot A or slot B, each).

## General Specifications

Although measurements are made with state of the art equipment, some measurement inaccuracy must be allowed for ( $\pm 5\%$ ).

5) The three values for the max. cable cross section are for single core, flexible wire and flexible wire with sleeve, respectively.

### 8.1.3 Mains Supply 3x525-600 V AC

	P18K	P22K	P30K
Compressor model	VZH088	VZH117	VZH170
Typical Shaft Output [kW]	22	30	50/37
Enclosure IP21, IP55, IP66	B2	B2	-
Enclosure IP20	B4	B4	B4
<b>Output current</b>			
Continuous (3 x 525-550 V ) [A]	36	43	54
Intermittent (3 x 525-550 V ) [A]	40	47	59
Continuous (3 x 525-600 V ) [A]	34	41	52
Intermittent (3 x 525-600 V ) [A]	37	45	57
Continuous kVA (550 V AC) [kVA]	34.3	41.0	49
Continuous kVA (575 V AC) [kVA]	33.9	40.8	47
<b>Max. input current</b>			
Continuous at 550 V [A]	32.7	39	49
Intermittent at 550 V [A]	36	43	54
Continuous at 575 V [A]	31	37	47
Intermittent at 575 V [A]	34	41	52
<b>Additional specifications</b>			
IP21, IP55, IP66 max. cable cross-section <sup>5)</sup> (mains, brake, load sharing) [mm <sup>2</sup> (AWG)] <sup>2)</sup>	35,-,-(2,-,-)	35,-,-(2,-,-)	50,-,- (1,-,-)
IP21, IP55, IP66 max. cable cross-section <sup>5)</sup> (motor) [mm <sup>2</sup> (AWG)] <sup>2)</sup>	35, 25, 25 (2, 4, 4)	35, 25, 25 (2, 4, 4)	35,25, 25 (2,4,4)
IP20 max. cable cross-section <sup>5)</sup> (mains, brake, motor and load sharing)	35,-,-(2,-,-)	35,-,-(2,-,-)	35,-,- (2,-,-)
Estimated power loss at rated max. load [W] <sup>4)</sup>	329	700	700
Weight, enclosure IP21, IP55, IP66 [kg]	27	27	59/27
Weight, enclosure IP20 [kg]	23.5	23.5	51.8/23.5
Efficiency <sup>4)</sup>	0.98	0.98	0.98

Table 8.3 Mains Supply 3x525-600 V AC

## General Specifications

### 8.2 General Technical Data

#### Mains Supply (L1, L2, L3)

Supply voltage	200-240 V $\pm$ 10%
Supply voltage	380-480 V $\pm$ 10%
Supply voltage	525-600 V $\pm$ 10%
Supply frequency	50/60 Hz
Max. imbalance temporary between mains phases	3.0 % of rated supply voltage
True Power Factor ( $\lambda$ )	$\geq$ 0.9 nominal at rated load
Displacement Power Factor ( $\cos \phi$ ) near unity	(> 0.98)
Switching on input supply L1, L2, L3 (power-ups) $\leq$ 7.5 kW	Max. 2 times/min.
Switching on input supply L1, L2, L3 (power-ups) $\geq$ 11 kW	Max. 1 time/min.
Environment according to EN60664-1	Overvoltage category III/pollution degree 2

The unit is suitable for use on a circuit capable of delivering not more than 100.000 RMS symmetrical Amperes, 240/500/600 V maximum

#### Motor Compressor Output (U, V, W)

Output voltage	0-100% of supply voltage
Switching on output	See 14-01 Switching Frequency

#### Cable lengths and cross sections

Max. motor cable length, screened/armoured	150 m
Max. motor cable length, unscreened/unarmoured	300 m
Max. cross section to motor, mains, load sharing and brake *	
Maximum cross section to control terminals, rigid wire	1.5 mm <sup>2</sup> /16 AWG (2 x 0.75 mm <sup>2</sup> )
Maximum cross section to control terminals, flexible cable	1 mm <sup>2</sup> /18 AWG
Maximum cross section to control terminals, cable with enclosed core	0.5 mm <sup>2</sup> /20 AWG
Minimum cross section to control terminals	0.25 mm <sup>2</sup>

\* See Table 8.1, Table 8.2 and Table 8.3 for more information!

#### Digital Inputs

Voltage level	0-24 V DC
Voltage level, logic.0. PNP	< 5 V DC
Voltage level, logic.1. PNP	> 10 V DC
Voltage level, logic .0. NPN2)	> 19 V DC
Voltage level, logic .1. NPN2)	< 14 V DC
Maximum voltage on input	28 V DC
Input resistance, Ri	approx. 4 k $\Omega$

## General Specifications

### Safe Stop Terminal 37

Voltage level	0 - 24 V DC
Voltage level, logic.0. PNP	< 4 V DC
Voltage level, logic.1. PNP	>20 V DC
Nominal input current at 24 V	50 mA <sub>rms</sub>
Nominal input current at 20 V	60 mA <sub>rms</sub>
Input capacitance	400 nF

Terminal 37 is fixed PNP logic

All digital inputs are galvanically isolated from the supply voltage (PELV) and other high-voltage terminals.

1. Terminals 27 and 29 can also be programmed as output.
2. Except safe stop input Terminal 37.
3. Terminal 37 can only be used as safe stop input.

Terminal 37 is suitable for category 3 installations according to EN 954-1 (safe stop according to category 0 EN 60204-1) as required by the EU Machinery Directive 98/37/EC. Terminal 37 and the Safe Stop function are designed in conformance with EN 60204-1, EN 50178, EN 61800-2, EN 61800-3, and EN 954-1. For correct and safe use of the Safe Stop function follow the related information and instructions in the Application Guidelines.

## 8

### Analog Inputs

Number of analog inputs	2
Terminal number	53, 54
Modes	Voltage or current
Mode select	Switch S201 and switch S202
Voltage mode	Switch S201/switch S202 = OFF (U)
Voltage level	-10 to +10 V (scaleable)
Input resistance, Ri: approx	10 k $\Omega$
Max. voltage	$\pm$ 20 V
Current mode	Switch S201/switch S202 = ON (I)
Current level	0/4 to 20 mA (scaleable)
Input resistance, Ri	approx. 200 $\Omega$
Max. current	30 mA
Resolution for analog inputs	10 bit (+ sign)
Accuracy of analog inputs	Max. error 0.5% of full scale
Bandwidth	100 Hz

The analog inputs are galvanically isolated from the supply voltage (PELV) and other high-voltage terminals.

### Digital Output

Programmable digital/pulse outputs	2
Terminal number	27, 29 <sup>1)</sup>
Voltage level at digital/frequency output	0-24 V
Max. output current (sink or source)	40 mA
Max. load at frequency output	1 k $\Omega$
Max. capacitive load at frequency output	10 nF
Minimum output frequency at frequency output	0 Hz
Maximum output frequency at frequency output	32 kHz
Accuracy of frequency output	Max. error: 0.1 % of full scale
Resolution of frequency outputs	12 bit

<sup>1)</sup> Terminal 27 and 29 can also be programmed as input. The digital output is galvanically isolated from the supply voltage (PELV) and other high-voltage terminals.

## General Specifications

### Analog Output

Number of programmable analog outputs	1
Terminal number	42
Current range at analog output	0/4 to 20 mA
Max. load to common at analog output	500 $\Omega$
Accuracy on analog output	Max. error: 0.5 % of full scale
Resolution on analog output	12 bit

The analog output is galvanically isolated from the supply voltage (PELV) and other high-voltage terminals

### Control Card, 24 V DC Output

Terminal number	12, 13
Max. load	200 mA

The 24 V DC supply is galvanically isolated from the supply voltage (PELV), but has the same potential as the analog and digital inputs and outputs.

### Control Card, 10 V DC Output

Terminal number	50
Output voltage	10.5 V $\pm$ 0.5 V
Max. load	15 mA

The 10 V DC supply is galvanically isolated from the supply voltage (PELV) and other high-voltage terminals

### Control Card, RS-485 Serial Communication

Terminal number	68 (P,TX+, RX+), 69 (N,TX-, RX-)
Terminal number 61	Common for terminals 68 and 69

The RS-485 serial communication circuit is functionally separated from other central circuits and galvanically isolated from the supplier voltage (PELV).

### Control Card, USB Serial Communication

USB standard	1.1 (Full speed)
USB plug	USB type B device plug

Connection to PC is carried out via a standard host/device USB cable.

The USB connection is galvanically isolated from the supply voltage (PELV) and other high-voltage terminals. The USB ground connection is not galvanically isolated from protection earth. Use only isolated laptop as PC connection to the USB connector on the frequency converter drive

### Relay Outputs

Programmable relay outputs	2
Relay 01 Terminal number	1-3 (break), 1-2 (make)
Max. terminal load (AC-1)1) on 1-3 (NC), 1-2 (NO) (Resistive load)	240 V AC, 2 A
Max. terminal load (AC-15)1) (Inductive load @ $\cos\phi$ 0.4)	240 V AC, 0.2 A
Max. terminal load (DC-1)1) on 1-2 (NO), 1-3 (NC) (Resistive load)	60 V DC, 1 A
Max. terminal load (DC-13)1) (Inductive load)	24 V DC, 0.1 A
Relay 02 ( only) Terminal number	4-6 (break), 4-5 (make)
Max. terminal load (AC-1)1) on 4-5 (NO) (Resistive load)	400 V AC, 2 A
Max. terminal load (AC-15)1) on 4-5 (NO) (Inductive load @ $\cos\phi$ 0.4)	240 V AC, 0.2 A
Max. terminal load (DC-1)1) on 4-5 (NO) (Resistive load)	80 V DC, 2 A



## General Specifications

### Surroundings

Enclosure ≤ enclosure type A	IP20, IP55
Enclosure ≥ enclosure type A, B	IP21, IP55
Enclosure kit available ≤ enclosure type A	IP21/TYPE 1/IP 4X top
Vibration test	1.0 g
Max. relative humidity	5% - 95% (IEC 721-3-3; Class 3K3 (non-condensing) during operation
Aggressive environment (IEC 721-3-3), uncoated	class 3C2
Aggressive environment (IEC 721-3-3), coated	class 3C3
Test method according to IEC 60068-2-43 H2S (10 days)	
Ambient temperature	Max. 50 °C

*Derating for high ambient temperature, see section on special conditions*

Minimum ambient temperature during full-scale operation	0 °C
Minimum ambient temperature at reduced performance	- 10 °C
Temperature during storage/transport	-25 - +65/70 °C
Maximum altitude above sea level without derating	1000 m
Maximum altitude above sea level with derating	3000 m

*Derating for high altitude, see section on special conditions*

EMC standards, Emission	EN 61800-3, EN 61000-6-3/4, EN 55011, IEC 61800-3 EN 61800-3, EN 61000-6-1/2,
EMC standards, Immunity	EN 61000-4-2, EN 61000-4-3, EN 61000-4-4, EN 61000-4-5, EN 61000-4-6

## Index

### A

Accessory bag.....	10, 21, 28
Accessory bag.....	19
Adjustable Warnings, 4-5*.....	49
Alarm message.....	134
Altitude.....	10
AMA.....	140, 143
Ambient temperature.....	10
Analog input.....	61, 139, 150
Analog output.....	151
Analog signal.....	139

### B

Brake control.....	140
Brake resistor.....	139
Branch circuit protection.....	25
Bus Jog, 8-9*.....	73

### C

Cable entry.....	13
Cable length.....	149
Catch up.....	53
Communication option.....	142
Comparators, 13-1*.....	77
Conductor.....	17
Configuration.....	70
Control cable.....	20, 21, 22
Control card.....	92, 93, 139, 151
Control terminal.....	33, 149
Control terminal, access.....	17
Control word timeout.....	141
Cross section.....	149
Ctrl. Word Settings, 8-1*.....	71
Current rating.....	140

### D

Data Readouts, 16-**.....	96
DC link.....	139
Decoupling plate.....	17, 21
Default setting.....	6, 19, 33, 93, 116
Diagnosis Read-Outs, 16-9*.....	100
Digital input.....	33, 44, 51, 56, 92, 108, 110, 140, 149, 151
Digital output.....	51, 92
Digital Outputs.....	55

Digital/Bus, 8-5*.....	72
Dimension, mechanical.....	12
Drive Status, 16-3*.....	97

### E

Earth leakage current.....	6, 7, 23
----------------------------	----------

### F

FC Port Diagnostics, 8-8*.....	73
FC Port Settings, 8-3*.....	71
Feedback.....	143
Fieldbus & FC Port, 16-8*.....	100
Fuse.....	25, 142
Fuses 200-240 V, UL fuses.....	26
Fuses 200-480 V, non-UL.....	26

### G

General Settings, 8-0*.....	70
General Status, 16-0*.....	96
Graphical display.....	31, 34

### H

Heat sink.....	143
----------------	-----

### I

Input terminal.....	139
Inputs and Outputs, 16-6*.....	98
Intermediate circuit.....	6
Intermediate Circuit.....	139

### K

Keypad.....	7, 28, 31, 32, 34, 39, 93, 104, 112, 115
Knockout.....	13

### L

LCP.....	38, 41
LCP Custom Readout, 0-3*.....	40
Leakage current.....	7, 16, 17, 23
Local reference.....	37
Logic Rules, 13-4*.....	83

### M

Mains connection, B1, B2, B3.....	13
Mains connection, B4, C1, C3.....	15
Mains supply.....	7, 20, 33, 92, 146, 149
Mechanical dimension.....	12
Mechanical mounting.....	11

---

**Index**

---

Motor compressor cable.....	16	Thermal load.....	97
Motor compressor connection.....	16	Timers, 13-2* .....	83
Motor connection.....	7	Torque.....	140
Motor current.....	39, 55, 114, 143	<b>V</b>	
Motor data.....	140, 144	Voltage imbalance.....	139
Motor Limits, 4-1*.....	48	Voltage level.....	7, 149, 150
Motor overload protection.....	6	<b>W</b>	
Motor power.....	143	Warning.....	134
Motor Status, 16-1*.....	96		
Motor thermal protection.....	23		
<b>O</b>			
Operating mode.....	37		
Output current.....	140		
Overheating.....	140		
Overtemperature.....	140		
<b>P</b>			
Phase loss.....	139		
Programming.....	139		
<b>R</b>			
Ramp up time.....	0		
Ref. & Feedb., 16-5*.....	98		
Relay output.....	55, 151		
Reset.....	139, 140, 144, 145		
RS Flip Flops, 13-1*.....	80		
<b>S</b>			
Safe stop.....	28		
Safe Stop.....	20, 150		
Safe Torque Off.....	7		
Safety instruction.....	6		
Screened/armoured.....	16, 21, 22, 149		
Sequence of operation.....	5		
Short circuit.....	141		
Short circuit protection.....	25		
Speed Bypass, 4-6*.....	50		
States, 13-5*.....	88		
Stripping.....	18		
Supply voltage.....	142		
Surroundings.....	152		
<b>T</b>			
TDU.....	33		
Terminal 54.....	145		



Trane - by Trane Technologies (NYSE: TT), a global climate innovator - creates comfortable, energy efficient indoor environments for commercial and residential applications. For more information, please visit [trane.com](http://trane.com) or [tranetechnologies.com](http://tranetechnologies.com).

Trane has a policy of continuous product and product data improvement and reserves the right to change design and specifications without notice. We are committed to using environmentally conscious print practices.

BAS-SVX60B-EN 18 Aug 2020  
Supersedes BAS-SVX60A-EN (Jul 2013)

©2020 Trane



130R0533